



# BX1697

## 2011-14 Chevy Cruze Eco Installation Instructions

**Attachment Tab Height: 14-1/4"**

**Attachment Tab Width: 20"**

**Serial Number**

**Please read BOTH these Installation Instructions and the General Information sheet prior to installing or operating this equipment.**

1. Blue Ox® towing products and accessories are intended to be installed by Blue Ox® Dealers who are familiar with our products and have the equipment and knowledge necessary to do "fit work". If needed, Blue Ox® Dealers can be found at [www.blueox.com](http://www.blueox.com) or by contacting our Technical Service Department at (402) 385-3051.
2. Many Blue Ox® baseplates are designed to use existing holes and hardware to mount the baseplate to the towed vehicle. Even though bolts are there, do not assume they are adequate for baseplate mounting. Always use the hardware supplied in the hardware kit and existing hardware as specified in the installation instructions.

| <b>Bolt Torque Specifications</b>    |         |         |
|--------------------------------------|---------|---------|
| Torque in Foot-Pounds for Inch Bolts |         |         |
| Bolt Size                            | Grade 5 | Grade 8 |
| 1/4"                                 | 10      | 14      |
| 5/16"                                | 19      | 29      |
| 3/8"                                 | 33      | 47      |
| 7/16"                                | 54      | 78      |
| 1/2"                                 | 78      | 119     |
| 5/8"                                 | 154     | 230     |
| 3/4"                                 | 257     | 380     |



| <b>Bolt Torque Specifications</b>      |           |            |
|--|-----------|------------|
| Torque in Foot-Pounds for Metric Bolts |           |            |
| Bolt Size                              | Grade 8.8 | Grade 10.9 |
| 6MM                                    | 6         | 8          |
| 8MM                                    | 16        | 22         |
| 10MM                                   | 31        | 40         |
| 12MM                                   | 54        | 70         |
| 14MM                                   | 89        | 117        |
| 16MM                                   | 161       | 230        |
| 18MM                                   | 222       | 318        |

If the front of your vehicle looks different than this, please contact us at (402)385-3051.

**Reference your vehicle owner's manual for manufacturer's towing specifications.**

## WARNING

Failure to read and follow these instructions could result in separation of the towed vehicle from the tow bar, causing property damage, loss of towed vehicle, personal injury or death.

## BX1697

### 2011-14 Chevy Cruze Eco Installation Instructions

**Instruction Notes:** The front fascia, belly pan, horn bracket and air intake tube are removed for baseplate installation. Trimming of air dam, front fascia and shutters is required. Some drilling is required.

Place all components that are removed on a flat, sturdy surface. All items will be reinstalled unless otherwise noted after the baseplate is installed.

The dimensional variations between otherwise identical vehicles can be considerable. While the baseplate was designed for easy installation, it may be necessary to tailor the baseplate slightly to compensate for vehicle manufacturer's tolerances.

The BX8869 Tail Light Wiring Kit is recommended for this vehicle.



Drill a hole according to the tail light wiring kit instructions.

### **NOTICE**

- Handling of some cosmetic parts when installing this product may require the use of protective covers, rags, specialty tools, etc. to prevent damage.
- When using power drills be aware of the dangers of torque and drill bit length.
- When using a reciprocating saw be aware of objects behind the cutting surface.
- Use a good quality paint to spray cut edges of frame to prevent rusting.
- Be sure that **ALL** electrical connections are plugged in and accessories are functioning properly before reinstalling the fascia.
- The baseplate is computer tested to your vehicle's GVWR, exceeding this weight will void the manufacturer's warranty.
- Be sure to use a sufficient amount of Loctite® Red on all bolt threads before tightening. Tighten all bolts according to the torque chart provided unless specified.
- Dealer or installer be certain the user receives these instruction sheets.
- If the baseplate is in an accident, it must be replaced. **DO NOT** use it again! An accident can cause unseen damage and using it again could result in more damage or serious injury. **DO NOT** use the baseplate if it is damaged or missing parts.

# BX1697

## 2011-14 Chevy Cruze Eco

### Installation Instructions

| Parts List |      |               |  |
|------------|------|---------------|--|
| Ref. No.   | Qty. | Part No.      | Description                                    |
| 1          | 1    | 61-6883.....  | WLDM'T, BX1697                                 |
| 2          | 1    | 61-6884.....  | WLDM'T, SUPPORT, DS, BX1697                    |
| 3          | 1    | 61-6885.....  | WLDM'T, SUPPORT, PS, BX1697                    |
| 4          | 8    | 61-5208.....  | WLD, NUT PLT, 1/4X1X1, 3/8"/14"WIRE            |
| 5          | 4    | .....         | EXISTING METRIC BOLT                           |
| 6          | 6    | 201-0440..... | 3/8-16 X 1 1/2 HEX BOLT, GRD.5, ZP             |
| 7          | 4    | 201-0444..... | 3/8-16 X 2 HEX BOLT GRADE 5 ZP.                |
| 8          | 10   | 203-0010..... | 3/8 LOCK WASHER, ZP                            |
| 9          | 2    | 202-0090..... | 3/8-16 HEX NYL. INS. LOCK NUT, ZP              |
| 10         | 2    | 62-3469.....  | ATT TAB ASSY, REM, SF/LB, 1 HOLE               |
| 11         | 3    | 201-0050..... | 1/4-20 X 3/4 HEX BOLT GRD.5, ZP                |
| 12         | 2    | 201-0192..... | 10-32 X 1/2 SLOT, RD. HD. SCREW                |
| 13         | 3    | 202-0102..... | 1/4-20 HEX NYL NUT, ZP                         |
| 14         | 2    | 203-0054..... | #10 LOCK WASHER                                |
| 15         | 2    | 202-0047..... | #10-32 HEX NUT                                 |
| 16         | 1    | 102-7204..... | BREAKAWAY BRKT, BX1697                         |
| 17         | 1    | 101-6135..... | BRACKET ELECTRICAL, 90 DEGR. (Not Shown)       |
| 2          | 2    | 226-0046..... | BASEPLATE SAFETY CABLE, 36" CL III (Not Shown) |
| 2          | 2    | 229-0359..... | QUICKLINK, 3/8, ZP (Not Shown)                 |
| 2          | 2    | 290-0437..... | RECEIVER, CAP PLUG (BLK) (Not Shown)           |
| 4          | 2    | 290-0275..... | CABLE TIE, 8 INCH NYLON (Not Shown)            |

| Tools Required      |                        |
|---------------------|------------------------|
| 8MM Socket          | Small Flat Screwdriver |
| 10MM Socket         | Utility Knife          |
| 13MM Socket         | Torque Wrench          |
| 18MM Socket/Wrench  | Tape Measure           |
| 9/16" Socket/Wrench | Drill                  |
| T20 Torx            | Hammer                 |
| Large Vise Grip     | 1 1/4" Hole Saw        |
| Diagonal Cutters    | 1/4" Drill Bit         |
| Reciprocating Saw   | 13/32" Drill Bit       |
| Pry Bar             | Loctite® RED           |

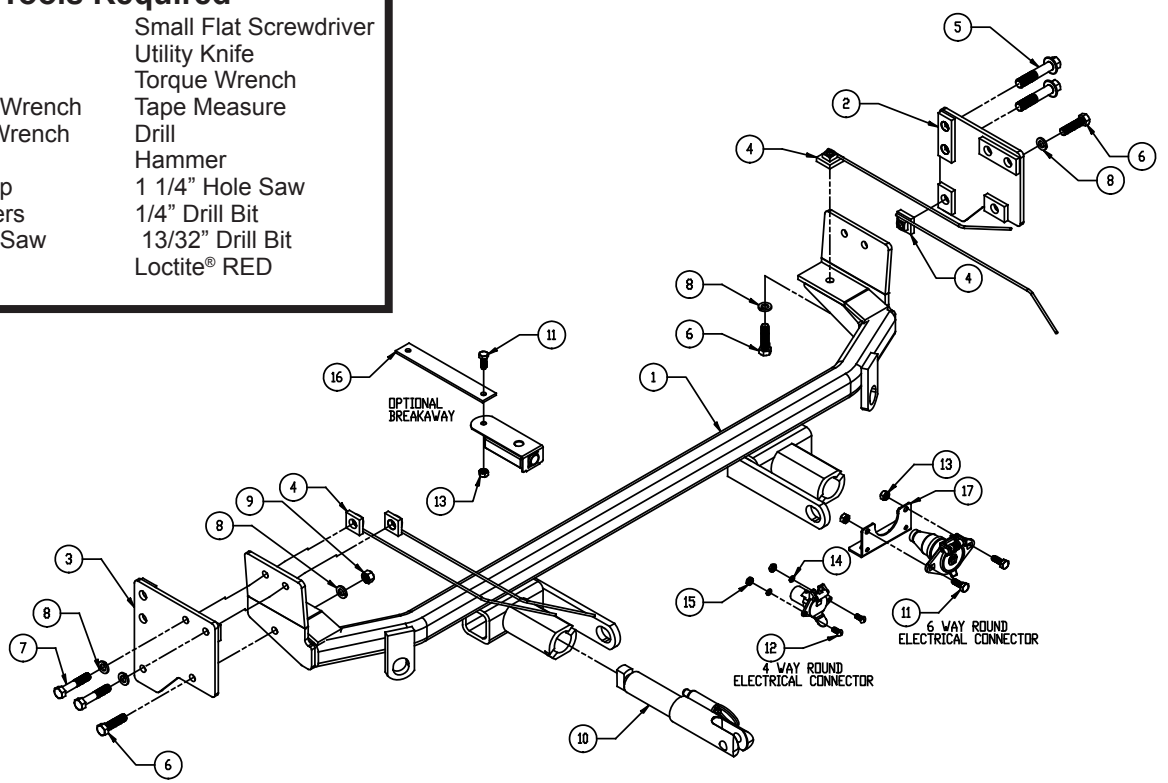

**Important:**

Use only genuine factory replacement parts on your baseplate. Do NOT substitute homemade or non-typical parts. If a bolt is lost or in need of replacement, for your safety and the preservation of your baseplate, be sure to use a replacement bolt of the same grade (In most cases it will be Grade 5, please reference the parts list above). Replacement parts may be ordered through your nearest Blue Ox® Dealer or Distributor. Failing to follow and/or altering these installation instructions in either installation or required equipment will void the manufacturer's warranty.



**BX1697**  
2011-14 Chevy Cruze Eco  
Installation Instructions

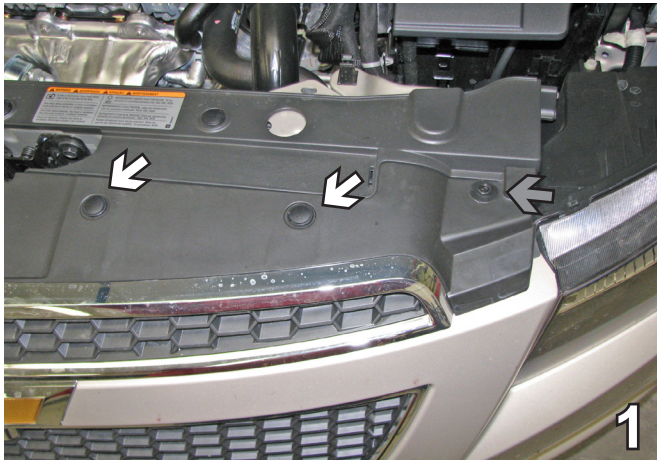

1. Remove the two (2) push pins (white arrows) from the black plastic cover just above the radiator. Using a 10MM socket, remove the metric bolt at the edge of the fascia (gray arrow). Do this on both sides. Set pins and bolts aside to be reinstalled later.



2. Just forward of front tire, on the edge of the wheel well, are three (3) bolts to remove with the T20 Torx, both sides. Set bolts aside to be reinstalled later.

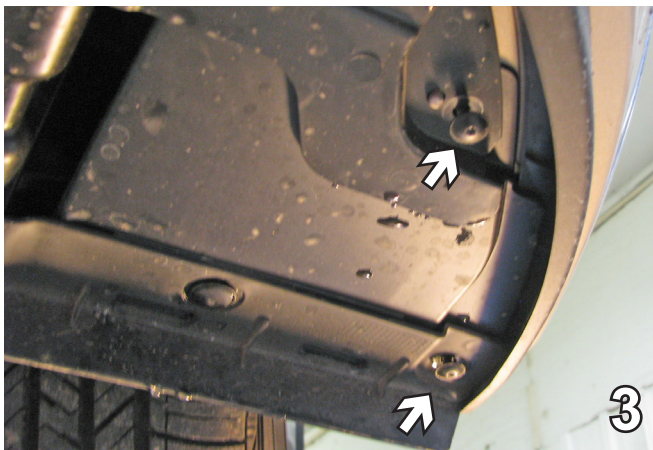

3. Remove the two (2) bolts from underneath the fascia, just forward of front tires with the T20 Torx, both sides. Set the bolts aside to be reinstalled later.

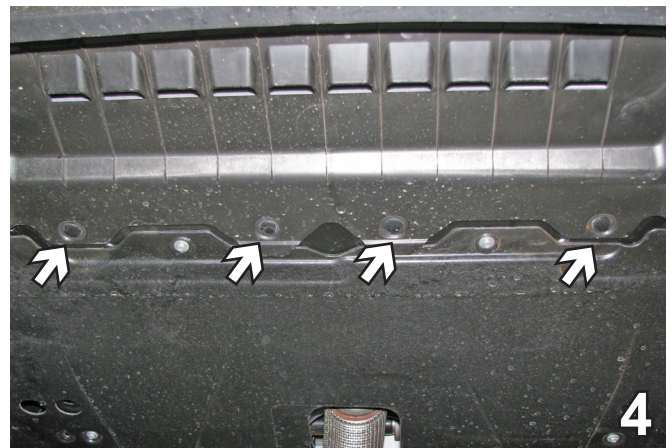

4. Remove the four (4) push pins from underneath the fascia. Set pins aside to be reinstalled later.



**BX1697**  
2011-14 Chevy Cruze Eco  
Installation Instructions

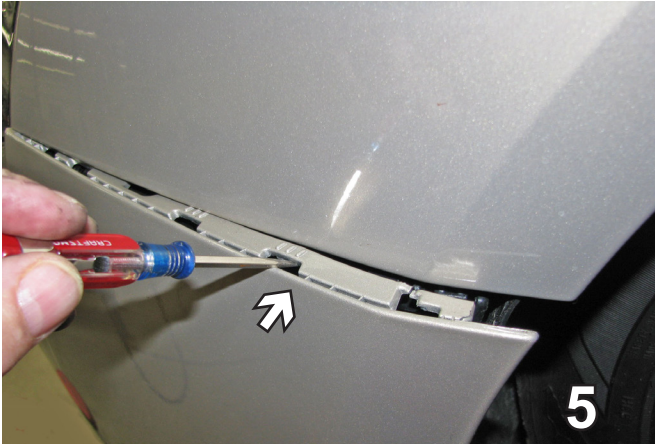

5. Pull out and to the side on the outside corner of the fascia next to the wheel to release the first tab. Using a small flat screwdriver push in on each of the four (4) tabs as you pull the fascia. Do this on both sides. Remove the fascia and set aside carefully to be reinstalled later.

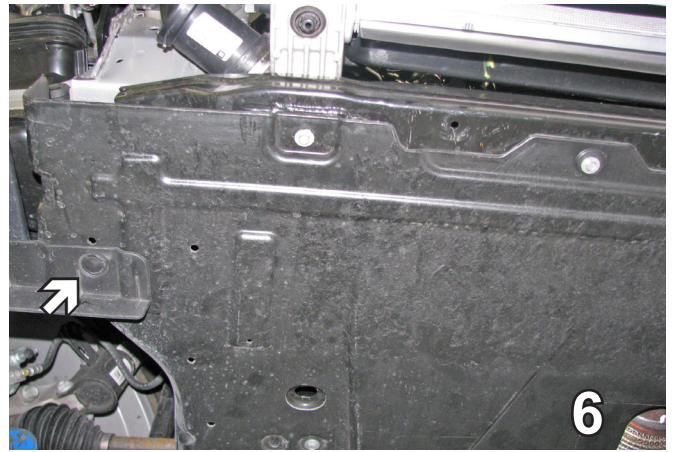

6. Remove one (1) push pin from the bottom of the belly pan. Do this on both sides. Set push pins aside to be reinstalled later.

7. Inside the wheel well, remove two (2) push pins. Do this on both sides. Set push pins aside to be reinstalled later.

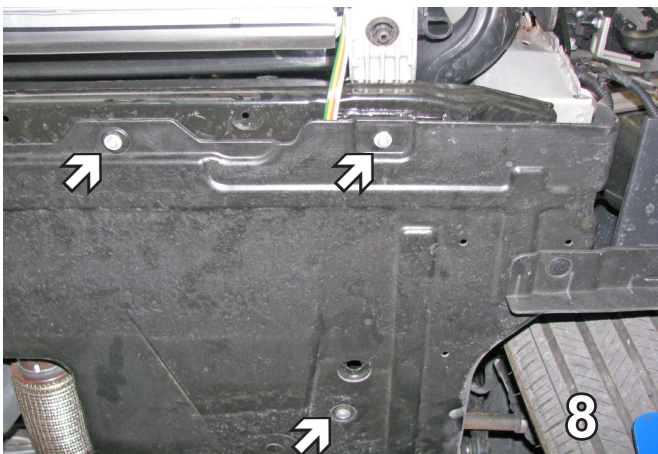

8. Using an 8MM socket, remove two (2) metric bolts across the front of the belly pan and another across from the tire. Do this on both sides. Set bolts aside to be reinstalled later.

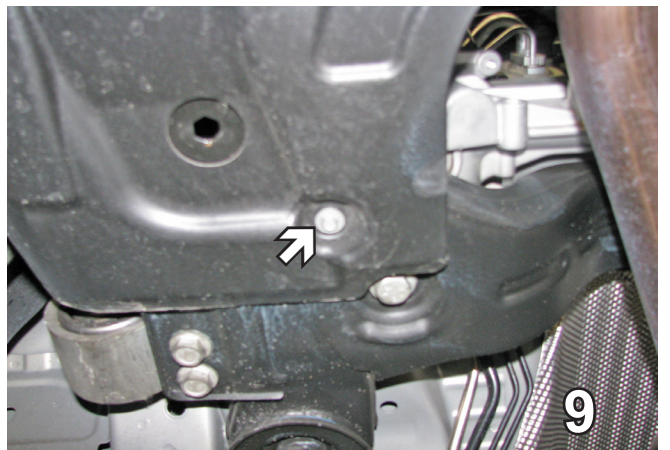

9. Using an 8MM socket, remove one (1) more metric bolt toward the back of the belly pan. Do this on both sides. Set bolts aside to be reinstalled later.



**BX1697**  
2011-14 Chevy Cruze Eco  
Installation Instructions

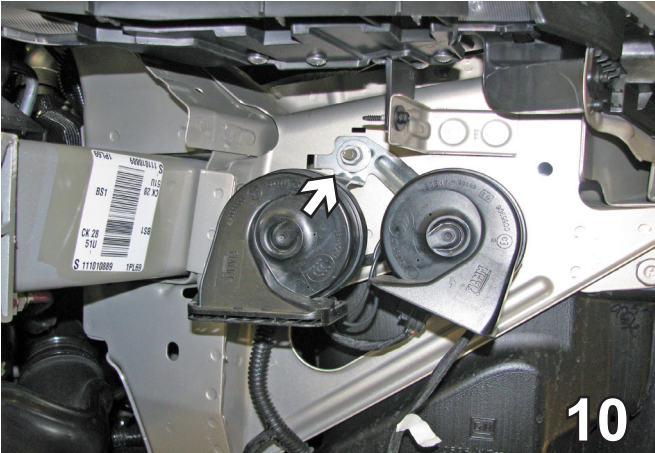

10. Using the 13MM socket, remove the metric bolt from the horn bracket on the driver side, unplug and set the bolt and horn aside to be reinstalled later.

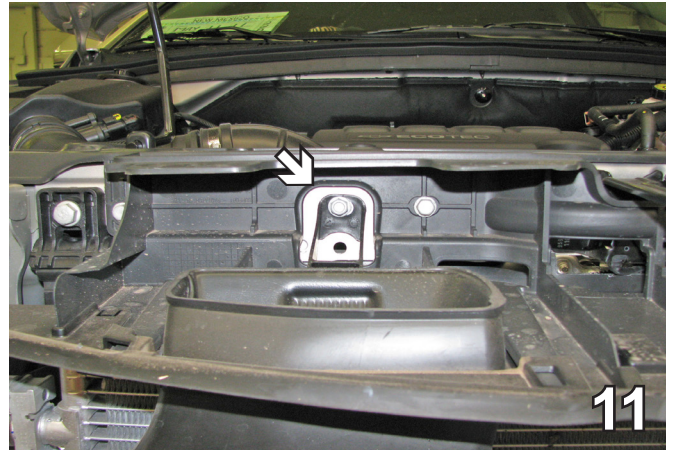

11. Using a 10MM socket, remove the metric bolt from the top of the air intake tube. Set the bolt aside to be reinstalled later.



12. On the passenger side below the headlight, detach the air intake tube from the bottom section of the tube. Set aside to be reinstalled later.



13. Using the utility knife, cut the plastic air dam along the top even with the bottom of the bumper and remove lower section. Do this on both sides.

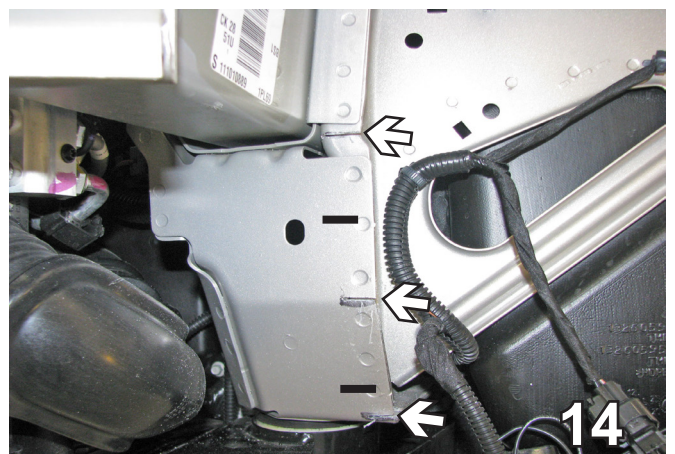

14. Cut frame webbing at the top, at the bend and at the bottom with a reciprocating saw. Be careful not to cut the main part of the frame. Do this on both sides.



**BX1697**  
2011-14 Chevy Cruze Eco  
Installation Instructions

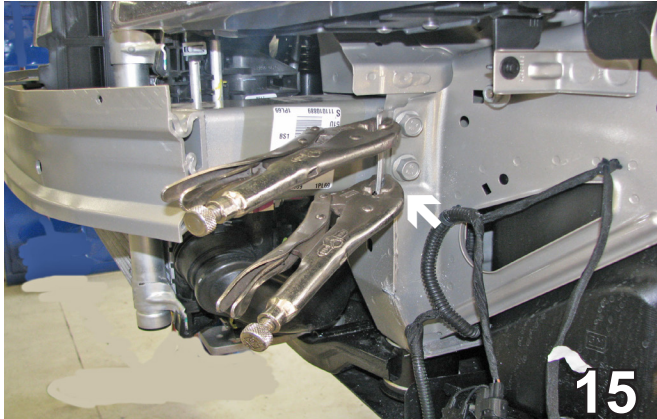

15. Using vice grips, bend the frame webbing over and flatten with a hammer. Do this on both sides.

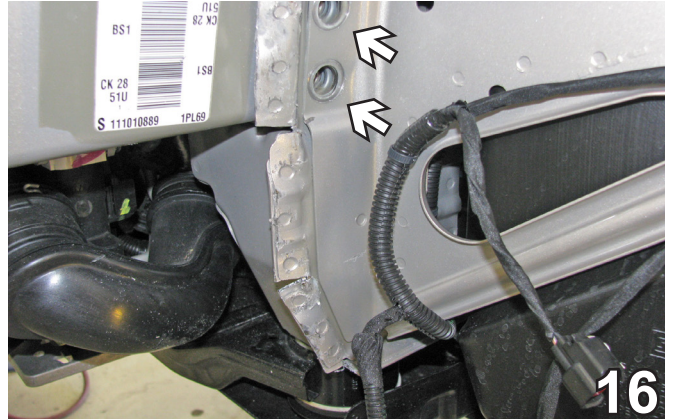

16. Using an 18MM socket and a wrench on the other side, remove the two (2) metric bolts next to the flattened area. Do this on both sides.

17. Using the 1-1/4" hole saw, drill a hole centered in the bumper, just in front of the frame end to be used for inserting 3/8" nut plates. Do this on both sides.

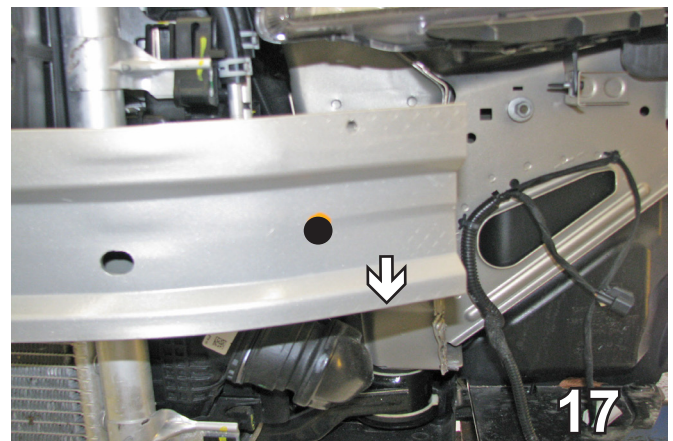

18. Inside the 1-1/2" drilled hole is a cross piece, which may need to be bent vertically with a pry bar in order to insert 3/8" nut plate. Do this on both sides.

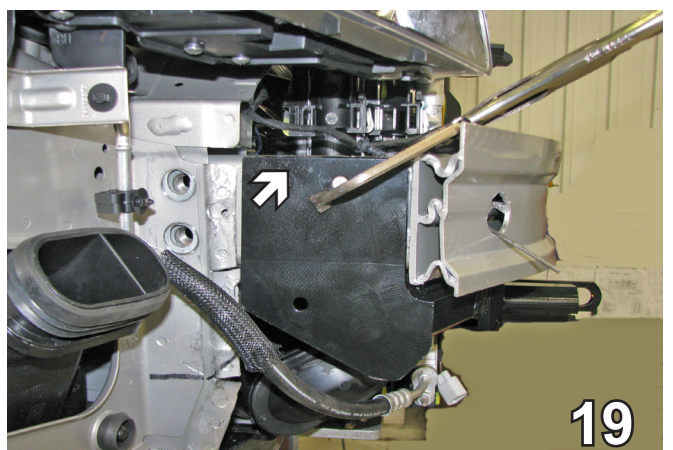

19. Slide the baseplate onto the frame rail flush with the top and as far forward as possible. Be sure support plate holes are in line with the existing holes (step 21). Then clamp the baseplate to the frame rail with the large vise grip.



**BX1697**  
2011-14 Chevy Cruze Eco  
Installation Instructions

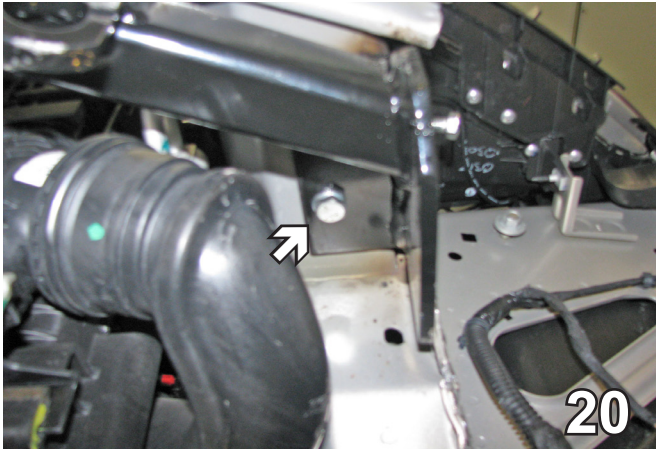

20. Using the baseplate as a template, drill a hole on the bottom side with the 13/32" drill bit. Insert 3/8"-16 x 1-1/2" hex bolt with Loctite Red and 3/8" lock washer. Attach to 3/8" nut plate inserted through the 1-1/2" lower opening on bumper. Do this to both sides.

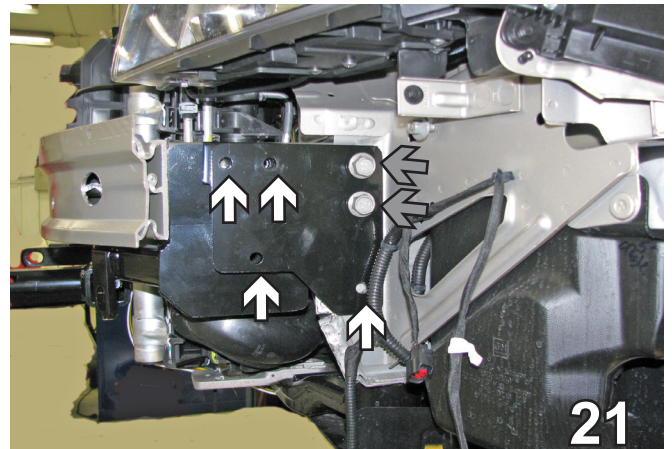

21. Using bolts removed in step 16, bolt the support plates to the existing holes on the outside of the frame (gray arrows). Use 18MM socket and a wrench on the other side to tighten bolts in order to sandwich the baseplate between the frame and the support plates. Using the support plate as a template, drill the other four (4) holes with a 13/32" drill bit (white arrows). Do this on both sides.

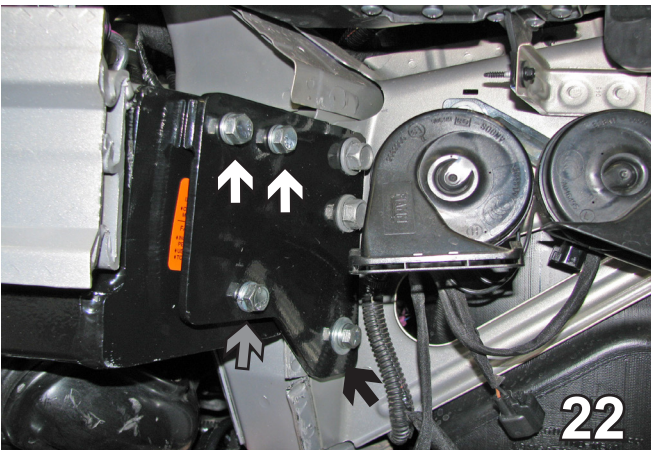

22. Bolt the upper two (2) holes (white arrows) with 3/8"-16 x 2" hex bolts, 3/8" lock washers and fasten to 3/8" nut plates inserted through the drilled hole in the bumper. In the lower outside hole (gray arrow) bolt the support plate to the baseplate with 3/8"-16 x 1-1/2" hex bolt fastened with 3/8" lock washer and 3/8"-16 hex nut. Be sure to use Loctite Red on all bolts. Do this on both sides.

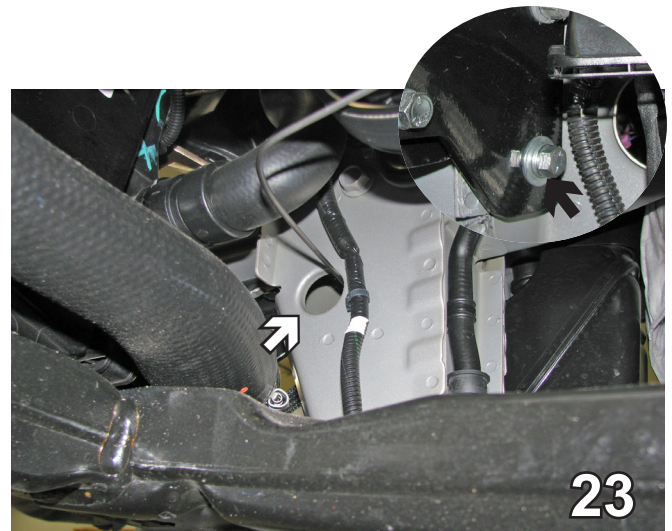

23. Insert 3/8"-16 x 1-1/2" hex bolt with 3/8" lock washer into the lower inside hole on the baseplate (black arrow step 22). Fasten to a 3/8" nut plate inserted through an existing hole underneath in the frame (white arrow). Do this on both sides. Be sure to use Loctite Red on the bolts.



**BX1697**  
**2011-14 Chevy Cruze Eco**  
**Installation Instructions**

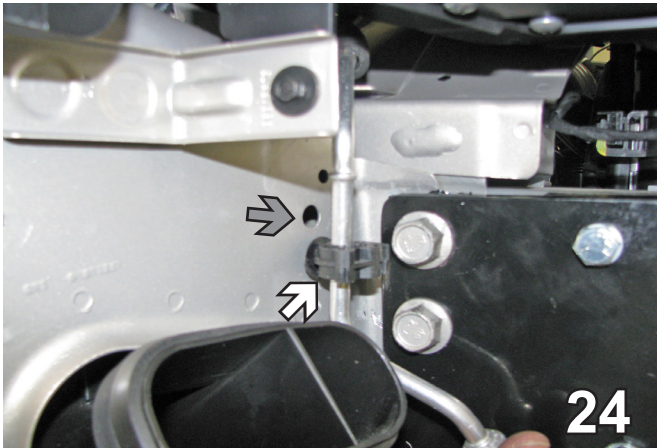

24. On the passenger side in the corner next to the baseplate, drill a 1/4" hole below the large hole (gray arrow) and pop the clip back in (white arrow). Be sure it is low enough so that the line clears the baseplate. Reattach the horn bracket on the driver's side. Reattach the air intake tube and the belly pan.

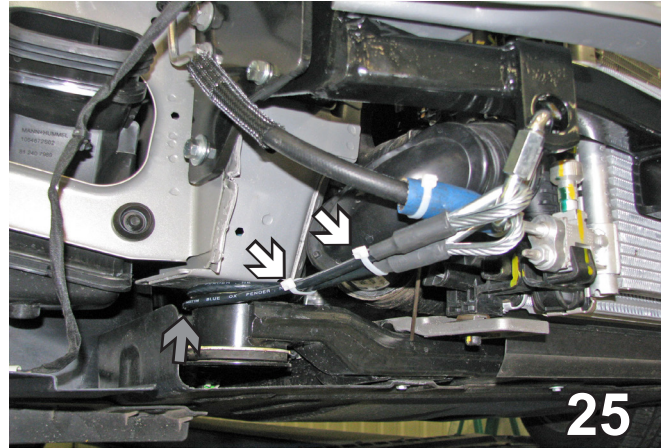

25. Attach the permanent baseplate safety cables to the provided convenience link on the front of baseplate. Cable ties are provided to reduce clearance issues with moving parts of engine compartment (white arrows). The photo above shows the recommended installation of the cables to lower cross member of vehicle (gray arrow). Additional options may interfere with suggested mounting; in this case secure the cables to a solid piece of the frame as described in the instructions included with the permanent baseplate safety cables. Be sure the safety cables do not rub against any hoses or moving parts. Do this to both sides of the vehicle.

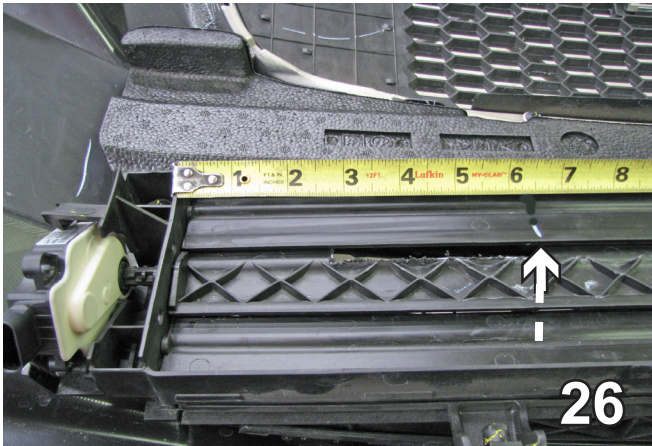

26. On the backside of the fascia, locate the top louver of the air shutter system, measure and mark over 6-1/2" from the left end of the air shutter system. Using the diagonal cutters, make a vertical cut across the louver and remove the 6-1/2" end portion. Do this to both sides of the vehicle. Driver side is shown.

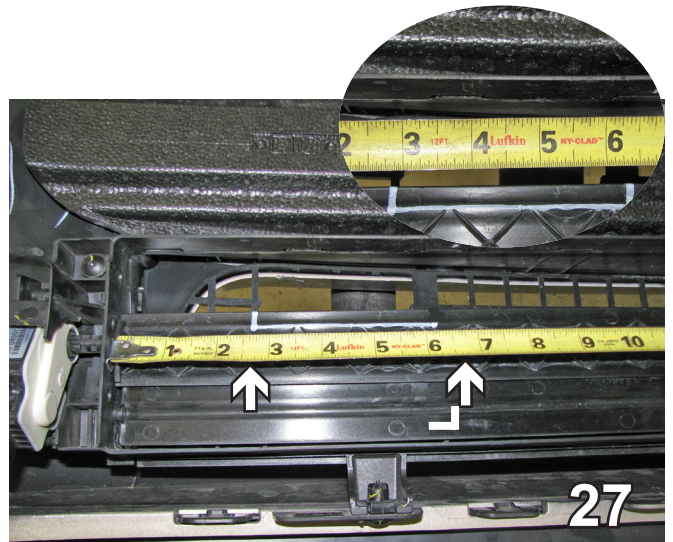

27. On the backside of the fascia, locate the left side of the middle louver on the air shutter system, measure over 2-3/4" mark the louver, continue to measure to 6-1/2", mark the louver again. Using the diagonal cutters and utility knife trim out the area between the marks 3/8" down from the top edge of the louver. Do this to both sides of the shutter system. Driver side is shown.

**BX1697**  
2011-14 Chevy Cruze Eco  
Installation Instructions



28. Hold fascia up to its original position. Using the diagonal cutters, cut out the upper outside area of the front fascia allowing room for the attachment tabs to come through the grille. Do this on both sides. Reinstall the fascia.



29. **Optional:** Attach the breakaway and the bracket to the underside of the vehicle with 1/4"-20 x 3/4" bolt and 1/4"-20 hex nut (white arrow). Cut opening in lower air dam to allow front of breakaway to come through (gray arrow).

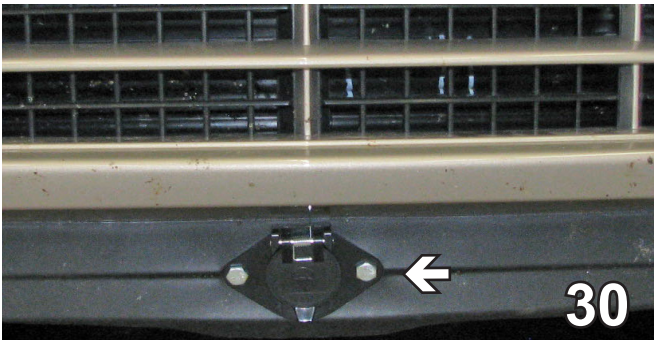

30. Possible location to mount the 4 or 6 pin electrical coupler on the fascia's lower air dam.



# General Information

1. Ensure that your product(s) are registered online at [www.blueox.com](http://www.blueox.com). It is crucial to register your product(s) so that you may be alerted of product offerings, updates, upgrades, maintenance and safety bulletins, and/or recalls.
2. **It is the owner's responsibility to inspect all towing equipment for cracked welds, missing or worn parts and loose bolts before each towing trip.** Be sure to use Loctite® Red on all bolts and tighten to the recommended specifications.
3. **It is the owner's responsibility to hook up all towing equipment per manufacturer's instructions/recommendations.**
4. Remove the attachment tabs when not in use (if applicable).

## Notice To Baseplate Installer

### 1. It is YOUR responsibility to watch for:

- Oil cooler and air conditioner lines
- Electrical wires and hoses
- Missing parts or attaching points on the frame

\*\* If the baseplate is improperly installed and is against a wire or hose, it could cause fluid leaks or electrical shorts some time after the actual baseplate installation.

## Permanent Baseplate Safety Cable Installation

Permanent baseplate safety cables are strongly recommended when towing a vehicle with a tow bar. The principle function of the permanent baseplate safety cables is to prevent the towed vehicle from breaking loose in the event the connection between the frame of the towed vehicle and the baseplate fails or becomes disconnected. The cables must be connected from the baseplate to the frame rail or cross member of the vehicle's frame. The illustrations below show the possible arrangements recommended by Blue Ox®. Each permanent baseplate safety cable must have an adequate weight rating for the towing system. The weight rating of the two (2) cables together will not qualify.

***Do not mount the permanent baseplate safety cables against wires, hoses or brake lines.***

These permanent baseplate safety cables should remain installed as long as the baseplate is installed on the vehicle. Permanent baseplate safety cables are to be used in conjunction with, and NOT a replacement for legally required safety cables attaching the towed vehicle to the towing vehicle.

### Option #1

(Baseplates with Convenience Link Tabs)



### Option #2

(Baseplates with out Convenience Link Tabs)



# BLUE OX ORIGINAL PURCHASERS THREE YEAR LIMITED WARRANTY

Automatic Equipment Manufacturing Company ("Automatic") warrants to the original (first) retail purchaser that this product, manufactured by Automatic, shall be free from defect in material and workmanship under normal use and service for a period of three years from the date of delivery.

During said three-year period, Automatic will repair or replace any parts that have been returned by the original purchaser, to the factory, transportation prepaid, and in Automatic's sole and absolute opinion found to be defective.

Limitations on Warranty Coverage:

Coverage under this warranty will be valid only if the customer warranty card is returned by the original purchaser within 30 days of purchase.

Coverage under this warranty will be effective only when a copy of the original invoice, showing date and place of purchase, accompanies any claim for warranty. This warranty is NON TRANSFERABLE.

This limited warranty will not cover, in any way or form, any alleged damages caused by incorrect or improper installation, improper use, modification or neglect of product, failure to properly service and maintain, misuse, act of God, accident or failure of the user to follow guidelines contained in the instructional material provided by Automatic.

This warranty does not cover normal wear and tear, paint or rust.

Warrantor assumes no responsibility to the owner for loss of use of product, loss of time, inconvenience or any other damage consequential or otherwise. Including, but not limited to mileage, expense of transporting of product, return shipping expense, mechanics travel time, telephone, road service, towing, and rental during repairs, travel, lodging, loss or damage to personal property or loss of earnings.

**REPAIR OR REPLACEMENT AS SET FORTH IN THIS LIMITED WARRANTY IS THE SOLE EXCLUSIVE REMEDY OF THE PURCHASER. AUTOMATIC SHALL NOT BE LIABLE FOR ANY INCIDENTAL OR CONSEQUENTIAL DAMAGES FOR BREACH OF ANY EXPRESS OR IMPLIED WARRANTY ON THIS PRODUCT. EXCEPT TO THE EXTENT PROHIBITED BY APPLICABLE LAW, ANY IMPLIED WARRANTY OF MERCHANTABILITY OR FITNESS FOR A PARTICULAR PURPOSE ON THIS PRODUCT IS LIMITED IN LENGTH TO THE DURATION OF THIS WARRANTY.**

Please visit <http://blueox.com/warranty/> to register your warranty

