

13920 82-04 CHEVY S10, S15, GMC SONOMA PICKUPS W/ ROLL PAN

10/26/2020

GROSS LOAD CAPACITY WHEN USED AS A WEIGHT CARRYING HITCH: 3,500 LBS. TRAILER WEIGHT & 350 LBS. TONGUE WEIGHT.
GROSS LOAD CAPACITY WHEN USED AS A WEIGHT DISTRIBUTION HITCH: 5,000 LBS. TRAILER WEIGHT & 500 LBS. TONGUE WEIGHT

*****DO NOT EXCEED VEHICLE MANUFACTURER'S RECOMMENDED TOWING CAPACITY.*****

| Parts List | | | |
|------------|-----|-------------|---------------------------------------|
| ITEM | QTY | PART NUMBER | DESCRIPTION |
| 1 | 8 | 10-10334 | HHCS, 1/2-13 UNC, 1-1/2, GRD8, YZ |
| 2 | 8 | 20-00062 | NUT, SER-FLANGE, 1/2-13 UNC, GRD8, YZ |

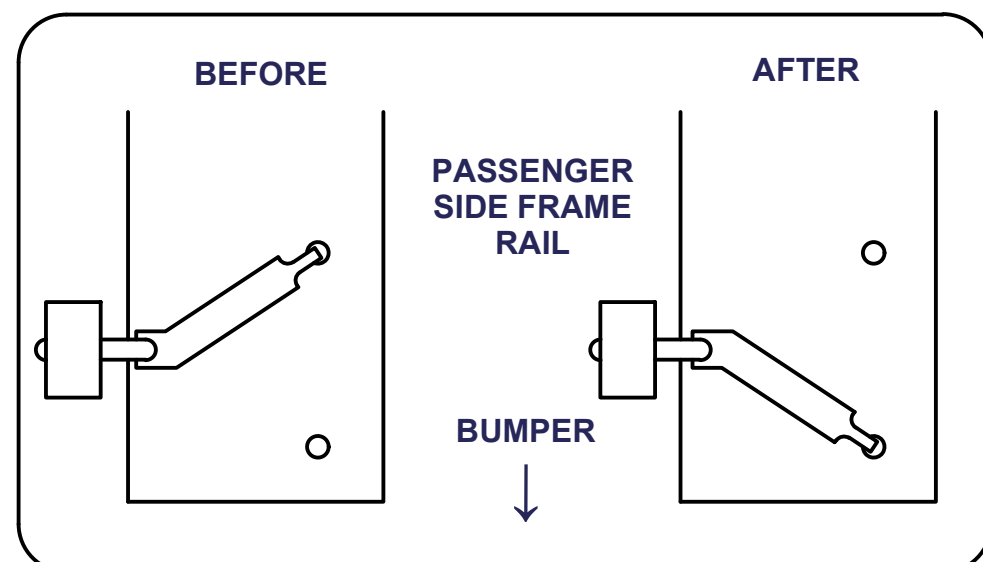

DRILL HOLES IF NOT PRESENT
(BOTH FRAME RAILS)

DRIVER SIDE
FRAME RAIL

PASSENGER SIDE
FRAME RAIL

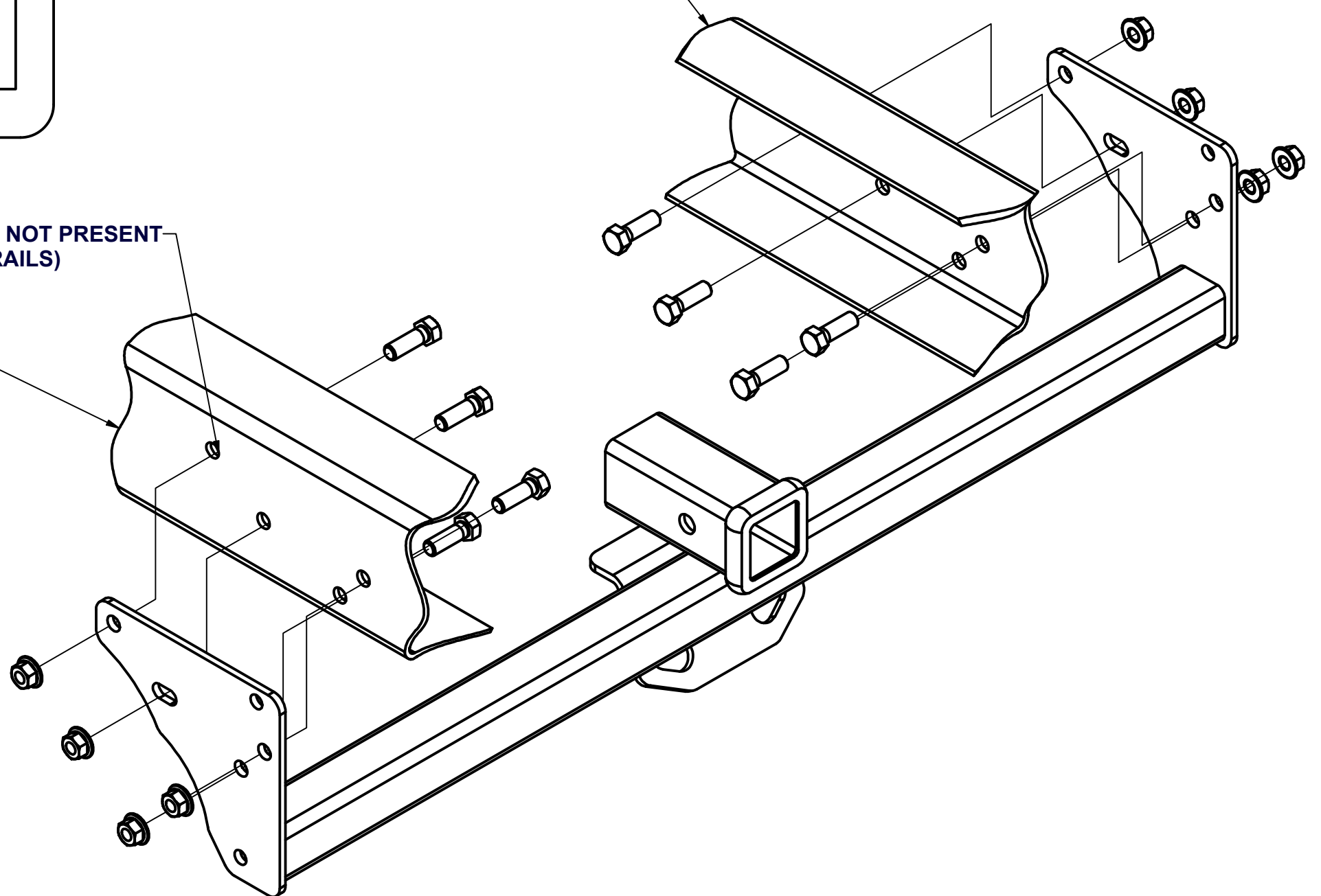

TOOLS REQUIRED

RATCHET

3/4" SOCKET

3/4" BOXED END WRENCH

DRILL W/ 17/32" BIT

AVIATOR SHEARS / TIN SNIPS

TORQUE WRENCH

HITCH WEIGHT: 27 LBS.

INSTALL TIME: 60 MINUTES

INSTALL NOTES:

- LOWER SPARE TIRE
- MAY REQUIRE DRILLING
- EXHAUST BRACKET RELOCATION
- TRIM ROLL PAN FOR BALL MOUNT

NOTE: CUTTING OF ROLL PAN IS REQUIRED

INSTALLATION STEPS

Note: Short box models will require the relocation of spare tire.

- 1) Loosen or remove spare tire as required. Short box models: remove the (2) rear exhaust hanger brackets.
- 2) Raise hitch into position and loosely install fasteners as shown above.
- 3) Some vehicle may require the drilling of holes, using a 17/32" drill bit, as shown.
- 4) Torque all 1/2" fasteners to 110 lb-ft.
- 5) For ball mount installation, cut the roll pan in the license plate area to provide access.

Note: License plate must be repositioned when the ball mount is installed.

- 6) Short box models: re-install hanger brackets, rear bracket must be flipped over.

PERIODICALLY CHECK THIS RECEIVER HITCH TO ENSURE THAT ALL FASTENERS ARE TIGHT AND THAT ALL STRUCTURAL COMPONENTS ARE SOUND.

Curt Manufacturing Inc., warrants this product to be free of defects in material and/or workmanship at the time of retail purchase by the original purchaser. If the product is found to be defective, Curt Manufacturing Inc., may repair or replace the product, at their option, when the product is returned, prepaid, with proof of purchase. Alteration to, misuse of, or improper installation of this product voids the warranty. Curt Manufacturing Inc.'s liability is limited to repair or replacement of products found to be defective, and specifically excludes liability for incidental or consequential loss or damage.