

13591

2005 - 2017 CHEVY EQUINOX / 2010 - 2017 GMC TERRAIN
2002 - 2007 SATURN VUE (REDLINE) / 2006 - 2009 PONTIAC TORRENT

4/10/2020

GROSS LOAD CAPACITY WHEN USED AS A WEIGHT CARRYING HITCH: 3,500 LBS. TRAILER WEIGHT & 350 LBS. TONGUE WEIGHT.
GROSS LOAD CAPACITY WHEN USED AS A WEIGHT DISTRIBUTION HITCH: 4,000 LBS. TRAILER WEIGHT & 400 LBS. TONGUE WEIGHT

*****DO NOT EXCEED VEHICLE MANUFACTURER'S RECOMMENDED TOWING CAPACITY.*****

HAVING INSTALLATION QUESTIONS? CALL TECHNICAL SUPPORT AT 1-877-287-8634

Parts List			
ITEM	QTY	PART NUMBER	DESCRIPTION
1	6	10-10386	HHCS,M12x1.75,40,CL10.9,YZ
2	6	30-00149	WASHER,S-CON,1/2,YZ
3	2	10-10272	BOLT,CAR,1/2-13 UNC,1-3/4,GRD8,YZ
4	2	CM-SP1	.250 x 1.50 x 2.00" SQUARE HOLE SPACER
5	2	20-00062	NUT, SER-FLANGE,1/2-13 UNC,GRD8,YZ
6	1	1_2 x 30 FISHWIRE	1/2" x 30" FISHWIRE

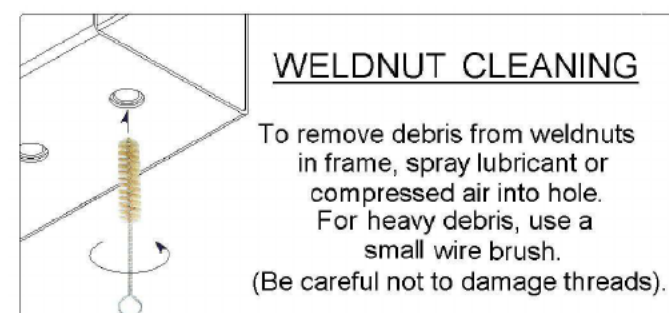
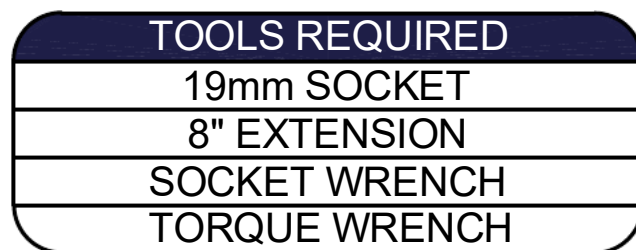
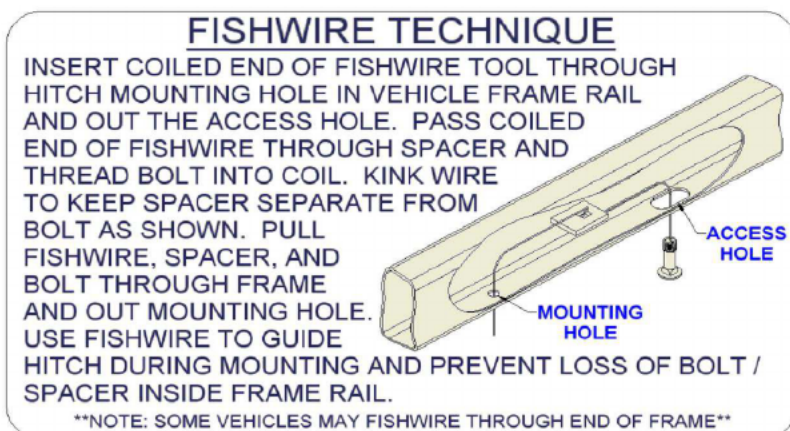

FISHWIRE CARRIAGE BOLTS, SQUARE HOLE SPACERS, AND FLANGE NUTS WHEN INSTALLING ON SATURN VUE AND SOME CHEVY EQUINOX / GMC TERRAIN MODELS MAY NEED TO ENLARGE HOLES TO 17/32" TO ENSURE CLEARANCE OF 1/2" BOLTS

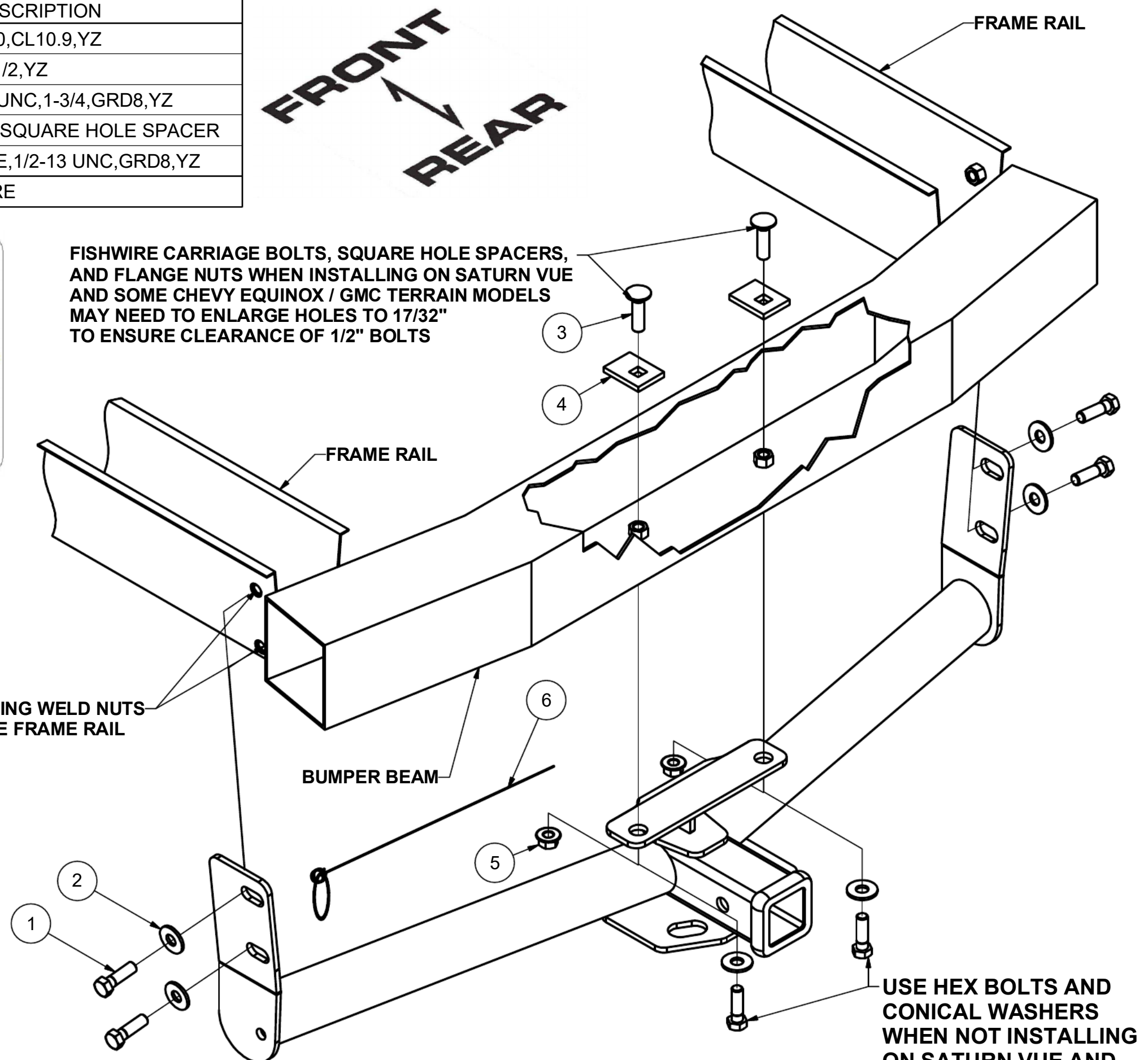

EXISTING WELD NUTS INSIDE FRAME RAIL

USE HEX BOLTS AND CONICAL WASHERS WHEN NOT INSTALLING ON SATURN VUE AND SOME CHEVY EQUINOX / GMC TERRAIN MODELS

NOTE: Fascia trimming required on Saturn Vue Redline

HITCH WEIGHT: 28 LBS.

INSTALL TIME

PROFESSIONAL: 30 MINUTES

NOVICE (DIY): 60 MINUTES

INSTALL NOTES:

NO DRILLING REQUIRED

INSTALLATION STEPS

1. On the Chevy Equinox and the GMC Terrain, it is necessary to remove the panel at the center of the fascia to provide space for hitch installation. (Return the panel to vehicle owner.)
2. Remove existing M12 fasteners from outside surfaces of frame rails. If present remove tie down brackets and return to customer.
3. Raise hitch into position and fasten to bumper beam using M12 bolts and conical washers.
4. Install M12 bolts and conical washers on outside surfaces of frame rails. (NOTE: If weldnuts contain debris; 1. Spray with penetrating oil, let soak for 5 minutes. 2. Clean weldnut with wire brush and compressed air. 3. If necessary, use a M12-1.75 tap to clean weldnut.)
5. Fishwire remaining carriage bolts and square hole spacers through end of bumper beam. (See FISHWIRE TECHNIQUE.) (NOTE: May need to enlarge holes to 17/32" to ensure clearance of 1/2" bolts)
6. Torque all M12 hardware to 79 ft-lbs. Torque all 1/2" hardware to 110 ft-lbs.

PERIODICALLY CHECK THIS RECEIVER HITCH TO ENSURE THAT ALL FASTENERS ARE TIGHT AND THAT ALL STRUCTURAL COMPONENTS ARE SOUND.

Curt Manufacturing Inc., warrants this product to be free of defects in material and/or workmanship at the time of retail purchase by the original purchaser. If the product is found to be defective, Curt Manufacturing Inc., may repair or replace the product, at their option, when the product is returned, prepaid, with proof of purchase. Alteration to, misuse of, or improper installation of this product voids the warranty. Curt Manufacturing Inc.'s liability is limited to repair or replacement of products found to be defective, and specifically excludes liability for incidental or consequential loss or damage.