

13558

INFINITI FX45 & FX35

8/12/2020

GROSS LOAD CAPACITY WHEN USED AS A WEIGHT CARRYING HITCH: 3,500 LBS. TRAILER WEIGHT & 350 LBS. TONGUE WEIGHT.

*****DO NOT EXCEED VEHICLE MANUFACTURER'S RECOMMENDED TOWING CAPACITY.*****

WARNING: ALL NON-TRAILER LOADS APPLIED TO THIS PRODUCT MUST BE SUPPORTED BY AUXILIARY STABILIZING STRAPS.

**** FAILURE TO PROPERLY SUPPORT NON-TRAILER LOADS WILL VOID PRODUCT WARRANTY****

HAVING INSTALLATION QUESTIONS? CALL TECHNICAL SUPPORT AT 877-287-8634

Parts List			
ITEM	QTY	PART NUMBER	DESCRIPTION
1	1	7_16 FISHWIRE	7/16" FISHWIRE
2	2	10-10419	HHCS,M12x1.25,30,CL10.9,YZ
3	2	30-00149	WASHER,S-CON,1/2,YZ
4	4	CM-SP7	.250 x 1.00 x 2.00" SQUARE HOLE SPACER
5	4	20-00103	NUT,SER-FLANGE,7/16-14 UNC,GRD8,YZ
6	4	10-10281	BOLT,CAR,7/16-14 UNC,1-1/4,GRD8,YZ

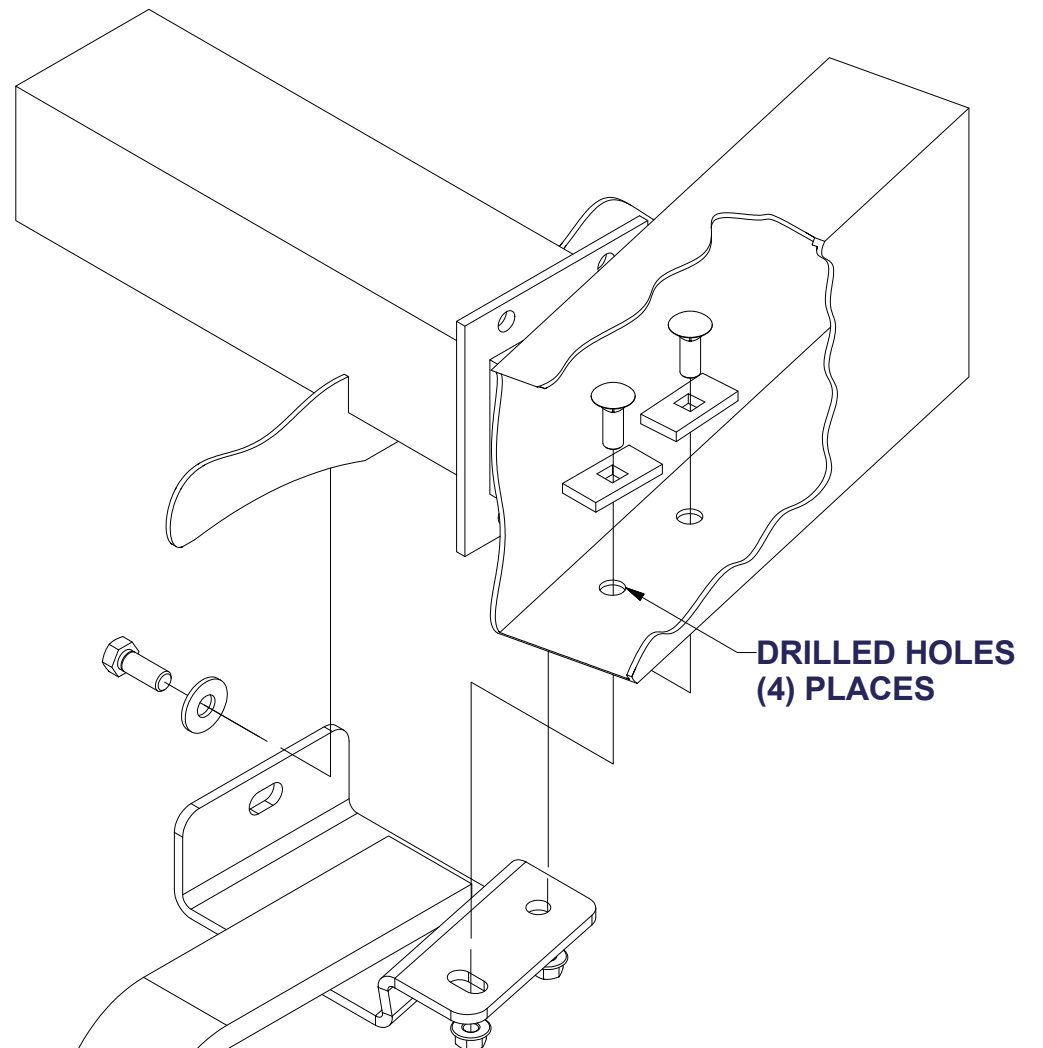
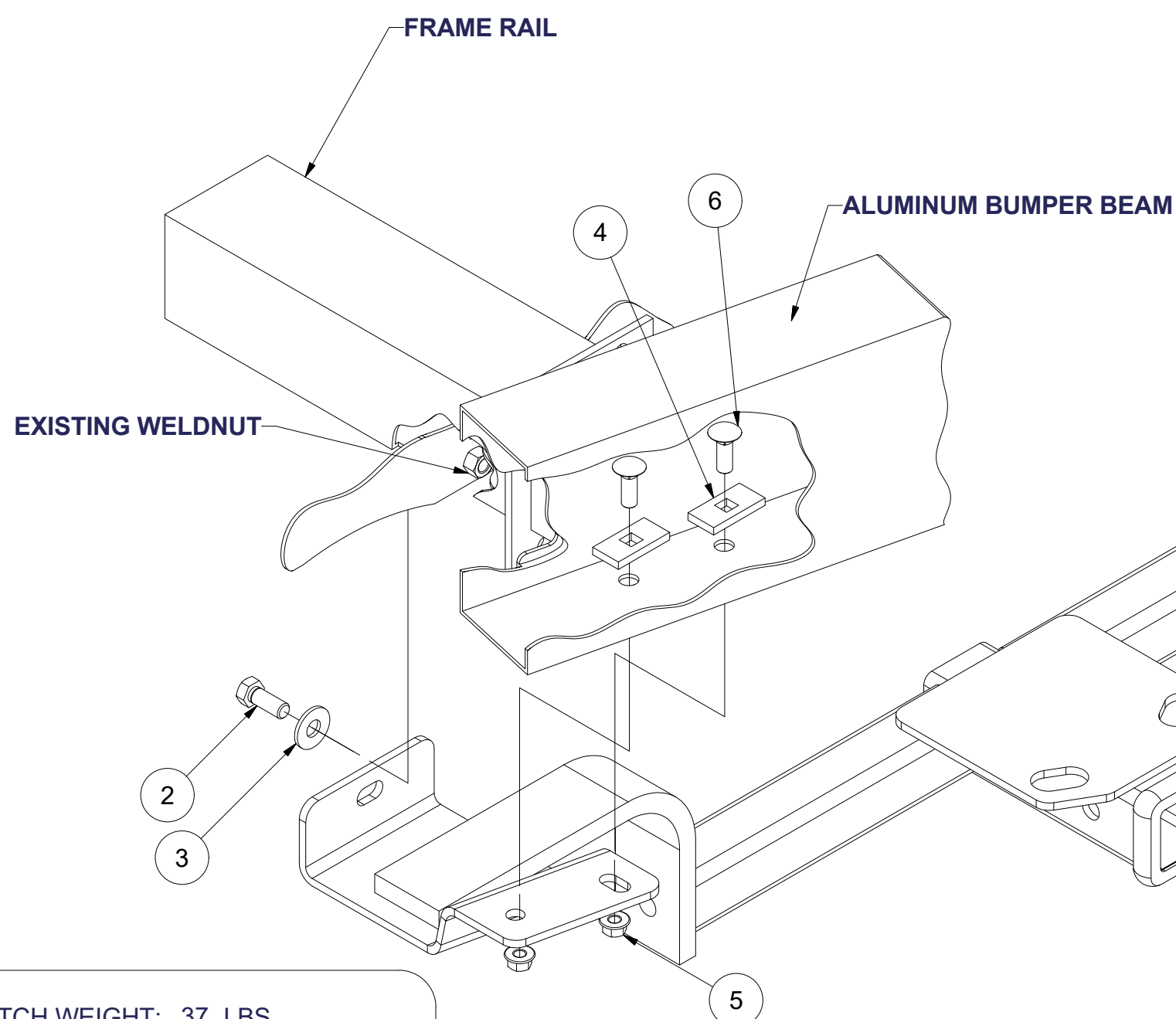
**RUBBER ISOLATOR
REMOVAL DIAGRAM**

This technique can be used if and Exhaust Hanger Removal Pliers is not available.

Using a 5/8" open end wrench, slide the wrench up to the rubber isolator, cradling the hanger rod as shown. Next place the flat edge of a pry bar between the wrench and the hanger stop or hanger rod. Then simply rotate the pry bar toward the wrench to remove the rubber isolator.

Note: Using a spray lubricant or soapy water on the hanger rod and the rubber isolator helps removal.

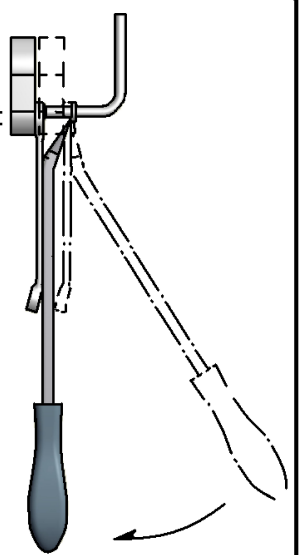

HITCH WEIGHT: 37 LBS.

INSTALL TIME

PROFESSIONAL: 45 MINUTES

NOVICE (DIY): 90 MINUTES

INSTALL NOTES:

- DRILLING REQUIRED
- LOWER EXHAUST
- TEMPORARILY REMOVE GRAVEL SHIELD

INSTALLATION STEPS

1. Remove left and right gravel shields by removing plastic push pins. **(Note: These will be reinstalled at end of installation.)** Lower exhaust hangers left, right and center.
2. Attach hitch to forward side of existing vertical weld nut plate using M12 bolts, each side.
3. Pull fascia rearward and drill four places in aluminum bumper beam using hitch as template.
4. Fishwire the 7/16" carriage bolts and spacers through open end of bumper into previously drilled holes and fasten with flange nuts.
5. Torque 7/16" fasteners to 70 lb.-ft. Torque M12 fasteners to 86 lb.-ft. Reattach exhaust and gravel shields.

PERIODICALLY CHECK THIS RECEIVER HITCH TO ENSURE THAT ALL FASTENERS ARE TIGHT AND THAT ALL STRUCTURAL COMPONENTS ARE SOUND.

FRONT
↑
REAR

Curt Manufacturing Inc., warrants this product to be free of defects in material and/or workmanship at the time of retail purchase by the original purchaser. If the product is found to be defective, Curt Manufacturing Inc., may repair or replace the product, at their option, when the product is returned, prepaid, with proof of purchase. Alteration to, misuse of, or improper installation of this product voids the warranty. Curt Manufacturing Inc.'s liability is limited to repair or replacement of products found to be defective, and specifically excludes liability for incidental or consequential loss or damage.

75882