

13250

## 03-06 DODGE &amp; FREIGHTLINER SPRINTER VAN

8/6/2020

WILL NOT FIT 140" DUAL WHEEL SPRINTER MODEL

GROSS LOAD CAPACITY WHEN USED AS A WEIGHT CARRYING HITCH: 6,000 LBS. TRAILER WEIGHT & 600 LBS. TONGUE WEIGHT.  
 GROSS LOAD CAPACITY WHEN USED AS A WEIGHT DISTRIBUTION HITCH: 10,000 LBS. TRAILER WEIGHT & 1,000 LBS. TONGUE WEIGHT

\*\*\*DO NOT EXCEED VEHICLE MANUFACTURER'S RECOMMENDED TOWING CAPACITY.\*\*\*

HAVING INSTALLATION QUESTIONS? CALL TECHNICAL SUPPORT AT 1-877-287-8634

Parts List			
ITEM	QTY	PART NUMBER	DESCRIPTION
1	1	1_2 FISHWIRE	1/2" FISHWIRE
2	2	CM-SP10	.250 x 1.00 x 2.50" SQUARE HOLE SPACER
3	8	20-00062	NUT, SER-FLANGE, 1/2-13 UNC, GRD8, YZ
4	6	10-10407	HHCS, 1/2-13 UNC, 4, GRD8, YZ
5	6	30-00133	WASHER, FLAT, 1/2, YZ
6	2	10-10287	BOLT, CAR, 1/2-13 UNC, 1-1/2, GRD8, YZ

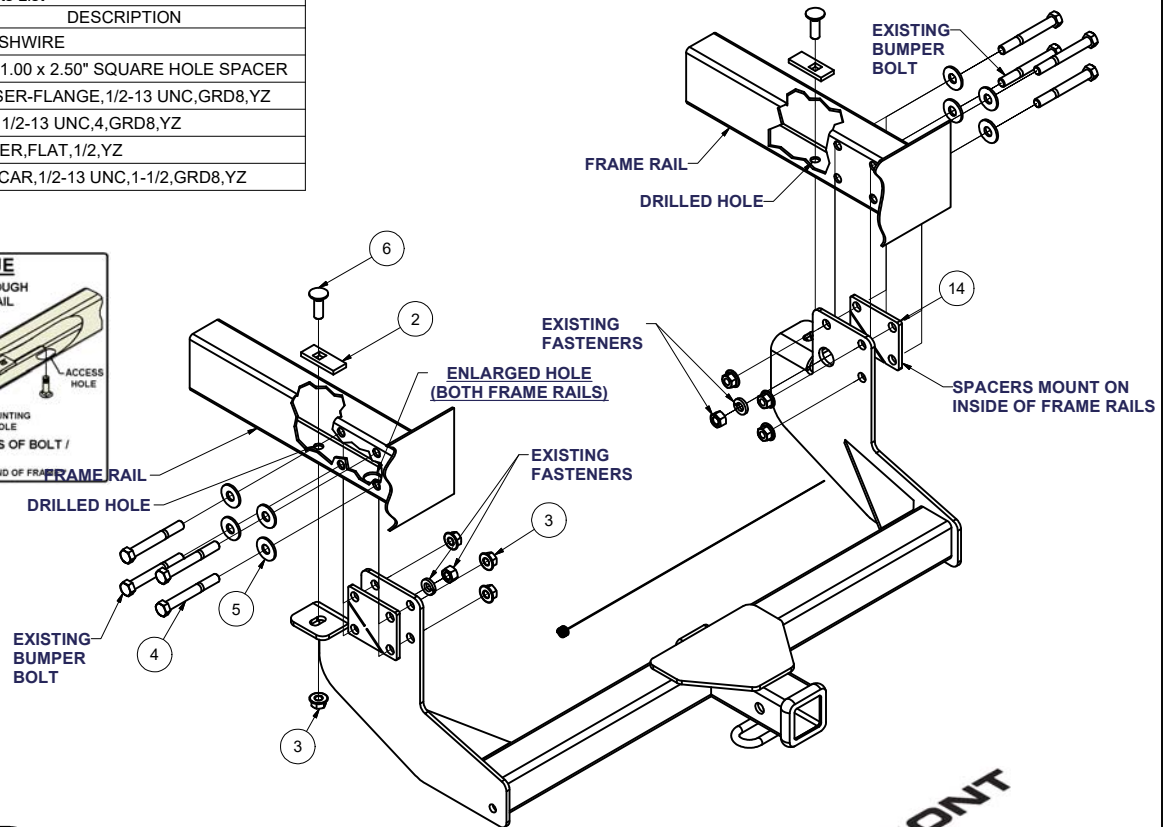
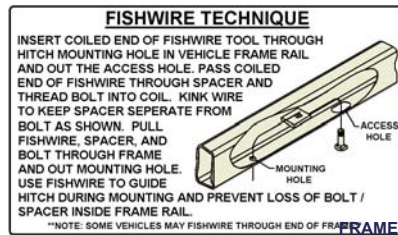

HITCH WEIGHT: 40 LBS.

**INSTALL TIME**

PROFESSIONAL: 45 MINUTES

NOVICE (DIY): 90 MINUTES

**INSTALL NOTES:**

- DRILLING REQUIRED
- BUMPER BRACKET MODIFICATION REQUIRED

BREAK OFF CORNER ON STEP BUMPER MODELS



1/4" SPACER PLATE

- WILL NOT FIT 140" DUAL WHEEL SPRINTER MODEL
- 118" WHEEL BASE VEHICLES NEED TO HAVE SPARE RELOCATED AND EXHAUST HANGER MODIFIED.
- ALL 158" WHEEL BASE VEHICLES MUST HAVE STEP BUMPER SUPPORT BRACE REMOVED FROM THE PASSENGER SIDE STEP BUMPER BRACKET.

## INSTALLATION STEPS

- 1) Remove (2) existing bumper bolts from each side of the frame. (For step bumper models only.)
- 2) Remove undercoating from mounting surfaces as needed.
- 3) For step bumper models, break off corner of 1/4" spacer plates as shown. Position spacer plates on the inside of frame rails. Raise hitch into position, using existing frame holes, install the 1/2" x 4" hex bolts, flatwashers, and flange nuts. (Note: Do not break off spacer corner for non-step bumper models.)
- 4) Reinstall the bumper bracket fasteners removed in step 1.
- 5) Using hitch as a template, drill (2) 9/16" holes through frame as shown. Enlarge existing holes in bottom of frame rails to 1 1/8".
- 6) Fishwire 1/2" carriage bolts and spacers through enlarged holes and secure with flange nuts.
- 7) Torque all 1/2" fasteners to 110 lb-ft and all M12 fasteners to 79 lb-ft (bumper bracket fasteners).

PERIODICALLY CHECK THIS RECEIVER HITCH TO ENSURE THAT ALL FASTENERS ARE TIGHT AND THAT ALL STRUCTURAL COMPONENTS ARE SOUND.

Curt Manufacturing Inc., warrants this product to be free of defects in material and/or workmanship at the time of retail purchase by the original purchaser. If the product is found to be defective, Curt Manufacturing Inc., may repair or replace the product, at their option, when the product is returned, prepaid, with proof of purchase. Alteration to, misuse of, or improper installation of this product voids the warranty. Curt Manufacturing Inc.'s liability is limited to repair or replacement of products found to be defective, and specifically excludes liability for incidental or consequential loss or damage.