

YEARS: 2013-PRESENT

MAKE: MERCEDES BENZ

MODEL: GLK350

STYLE: SUV

**WARNING: NEVER EXCEED YOUR VEHICLE MANUFACTURER'S RECOMMENDED TOWING CAPACITY**  
 For more information log onto [www.curtmfg.com](http://www.curtmfg.com) & for helpful towing tips log onto [www.hitchinfo.com](http://www.hitchinfo.com)

**WEIGHT CARRYING:**  
 TRAILER WEIGHT: 3,500 LBS.  
 TONGUE WEIGHT: 525 LBS.

**PRO INSTALL TIME: 45 MIN.**  
**NOVICE INSTALL TIME: 90 MIN.**

IF YOU ARE HESITANT TO UNDERTAKE THIS TASK ON YOUR OWN, CONTACT AN AUTHORIZED CURT INSTALLER FOR ADDITIONAL ASSISTANCE.

**INSTALLATION REQUIRES:**

|                            |                      |                           |
|----------------------------|----------------------|---------------------------|
|                            |                      |                           |
| <b>SAFETY GLASSES</b>      | <b>RATCHET</b>       | <b>T40 TORXBIT SOCKET</b> |
|                            |                      |                           |
| <b>6" SOCKET EXTENSION</b> | <b>SCREW DRIVER</b>  | <b>WIRE PIPE BRUSH</b>    |
|                            |                      |                           |
| <b>DRILL BIT 1/2"</b>      | <b>POWER DRILL</b>   | <b>DIE GRINDER</b>        |
|                            |                      |                           |
| <b>3/4" 11/16" SOCKET</b>  | <b>TORQUE WRENCH</b> |                           |

**INSTALLATION TIPS:**

- BEFORE YOU BEGIN INSTALLATION, READ ALL INSTRUCTIONS THOROUGHLY.
- TO EASE INSTALLATION, 2 PEOPLE MAY BE REQUIRED.
- USING PROPER TOOLS WILL GREATLY IMPROVE THE QUALITY OF THE INSTALL AND REDUCE THE TIME REQUIRED.
- NEED HELP OR HAVE SOME QUESTIONS? CALL TECHNICAL SUPPORT AT 877.287.8634

**LEVEL OF DIFFICULTY: MODERATE**

| EASY | MODERATE           | CHALLENGING |
|------|--------------------|-------------|
|      | - ENLARGE HOLES    |             |
|      | - LOWER EXHAUST    |             |
|      | - WELDNUT CLEANING |             |
|      |                    |             |
|      |                    |             |

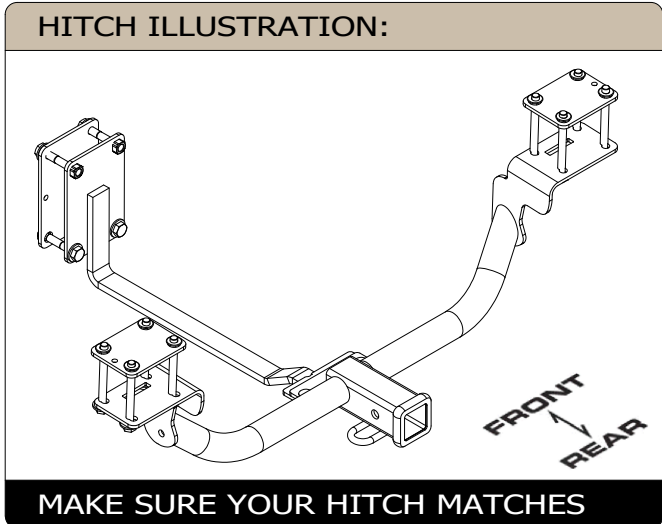

**PERIODICALLY CHECK THIS RECEIVER HITCH TO ENSURE ALL FASTENERS ARE TIGHT AND ALL STRUCTURAL COMPONENTS ARE SOUND**  
 CURT Manufacturing LLC. warrants this product to be free of defects in material and/or workmanship at the time of retail purchase by the original purchaser. If the product is found to be defective, CURT Manufacturing LLC. may repair or replace the product at their option, when the product is returned, prepaid, with proof of purchase. Alteration to, misuse of, or improper installation of this product voids the warranty. CURT Manufacturing LLC.'s liability is limited to repair or replacement of products found to be defective, and specifically excludes liability for incidental or consequential loss or damage.  
 For more information log onto [www.curtmfg.com](http://www.curtmfg.com)  
 This product complies with safety specifications and requirements for connecting devices and towing systems of the state of New York, V.E.S.C.Regulation V-5 and SAE J684.

# INSTALLATION WALKTHROUGH:

| Parts List |     |             |  |
|------------|-----|-------------|--|
| ITEM       | QTY | PART NUMBER | DESCRIPTION                            |
| 1          | 2   | CM-NP1W     | NUT PLATE WELDMNT                      |
| 2          | 8   | 10-10564    | HHCS, 1/2-13 UNC, 5, GRD5, ZP          |
| 3          | 2   | 20-00103    | NUT, SER-FLANGE, 7/16-14 UNC, GRD8, YZ |
| 4          | 12  | 30-00149    | WASHER, S-CON, 1/2, YZ                 |
| 5          | 2   | 10-10311    | BOLT, CAR, 7/16-14 UNC, 1, GRD8, YZ    |
| 6          | 4   | 10-10358    | HHCS, 1/2-13 UNC, 2-1/2, GRD5, CZ      |
| 7          | 1   | 13177-NPW   | NUT PLATE WELDMNT                      |

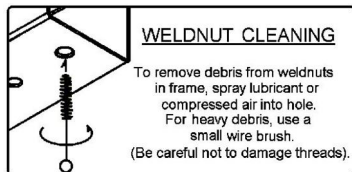
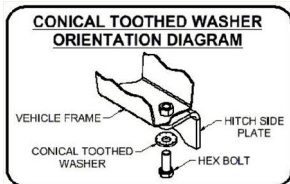
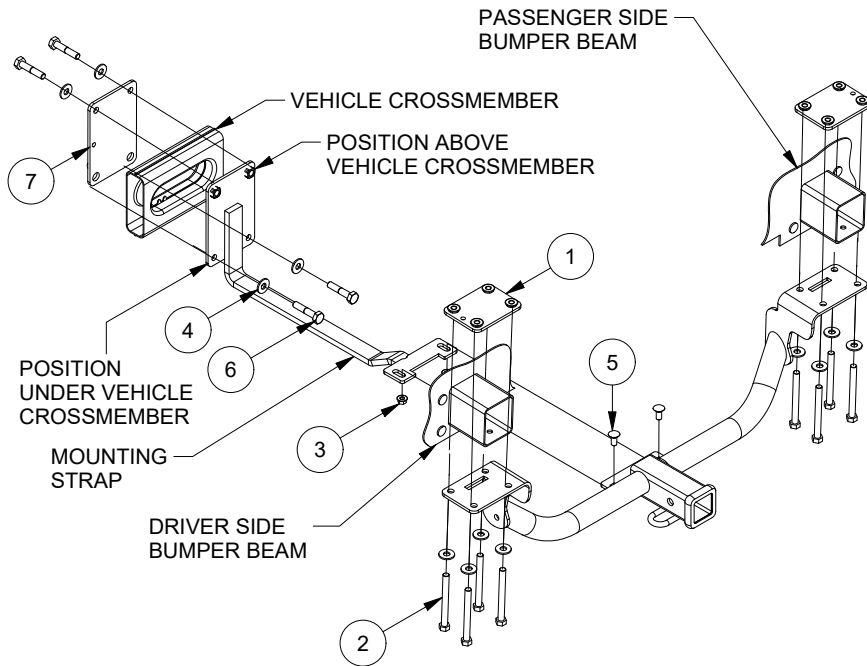

**FRONT**  
↕  
**REAR**

1. Remove 3 fascia clips from each side of the vehicle with a flat head screwdriver. This will allow for the fascia to flex slightly for socket access during installation.

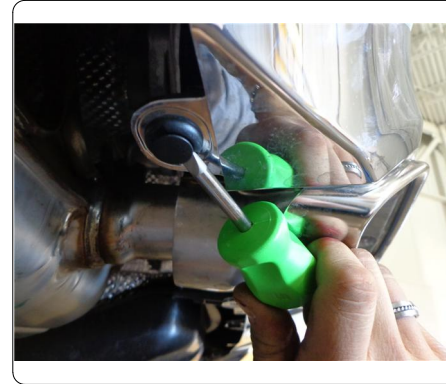

2. Remove exhaust tips by removing T40 torx screws from 3 locations on each side of the vehicle with a short torx bit and ratchet extension. Tips will be reinstalled when hitch installation is complete.





## INSTALLATION WALKTHROUGH:

3. Lower exhaust by removing (2) isolators on the driver side muffler, (2) isolators on the passenger side muffler, and (2) isolators forward of the mufflers. Note: Exhaust can pivot on driver side at ball joint location for increased access to rear vehicle mounting location.

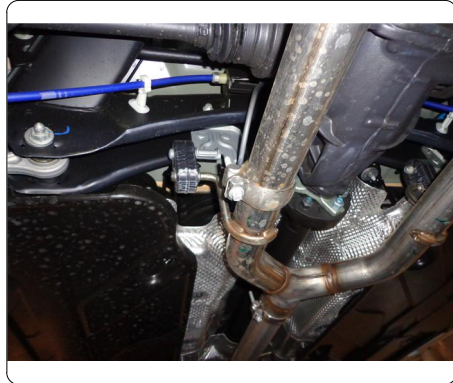

4. Locate plastic fascia support webbing and drill out center inboard section. Enlarge section for 3/4" socket access in order to tighten hitch to nut plates over bumper beam.



5. Locate supplied nut plates from hitch and hardware assembly. Nut plate weldnut threads may need to be cleaned with a wire brush before assembly.

6. Place supplied nut plates over bumper beam, as shown.

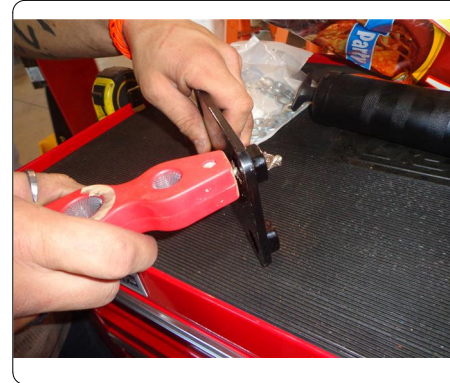

7. Raise hitch into position over exhaust.

8. Secure hitch to nut plates, with finger tightened 1/2" x 5" hex bolts and 1/2" conical toothed washers, as shown. (Note: Be sure to slide hitch as far forward as possible but not so it rests on the weld seam on the vehicle bumper beams.)





## INSTALLATION WALKTHROUGH:

9. Raise mounting strap behind vehicle crossmember, as shown.
10. Secure mounting strap to hitch with finger tightened 7/16" hex flange nuts.



11. Raise nut plate in front of vehicle cross member.
12. Secure nut plate to mounting strap with finger tightened 1/2" x 2 1/2" hex bolts and 1/2" conical toothed washers.

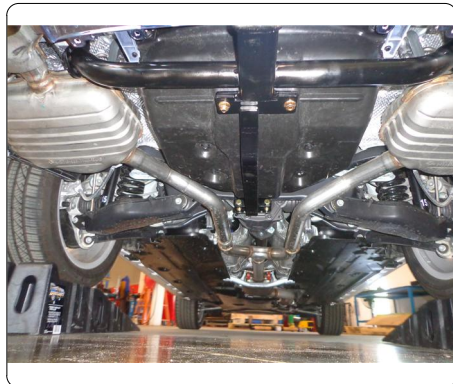
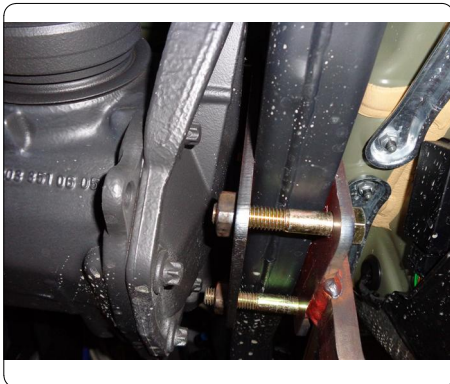

13. Torque all 1/2-13 hex bolts to 75 lb-ft. Torque all 7/16" hardware to 59 lb-ft.
14. Raise exhaust back into position.



15. Reattach exhaust tip (3 mounting locations each side.)
16. Reattach fascia clips (3 locations each side of vehicle.)

Installation is complete.



13177

MERCEDES BENZ GLK350

4/20/2021

PAGE 1 OF 2

GROSS LOAD CAPACITY WHEN USED AS A WEIGHT CARRYING HITCH: 3,500 LBS. TRAILER WEIGHT & 525 LBS. TONGUE WEIGHT.

**\*\*\*DO NOT EXCEED VEHICLE MANUFACTURER'S RECOMMENDED TOWING CAPACITY.\*\*\***

WARNING: ALL NON-TRAILER LOADS APPLIED TO THIS PRODUCT MUST BE SUPPORTED BY AUXILIARY STABILIZING STRAPS.

**\*\* FAILURE TO PROPERLY SUPPORT NON-TRAILER LOADS WILL VOID PRODUCT WARRANTY\*\***

HAVING INSTALLATION QUESTIONS? CALL TECHNICAL SUPPORT AT 1-877-287-8634

| Parts List |     |             |                                    |
|------------|-----|-------------|------------------------------------|
| ITEM       | QTY | PART NUMBER | DESCRIPTION                        |
| 1          | 12  | 30-00149    | WASHER,S-CON,1/2,YZ                |
| 2          | 2   | 20-00103    | NUT,SER-FLANGE,7/16-14 UNC,GRD8,YZ |
| 3          | 8   | 10-10564    | HHCS,1/2-13 UNC,5, GRD5, ZP        |
| 4          | 2   | 10-10311    | BOLT,CAR,7/16-14 UNC,1,GRD8,YZ     |
| 5          | 4   | 10-10358    | HHCS,1/2-13 UNC,2-1/2,GRD5,CZ      |
| 6          | 2   | CM-NP1W     | NUT PLATE WELDMENT                 |
| 7          | 1   | 13177-NPW   | NUT PLATE WELDMENT                 |

**RUBBER ISOLATOR REMOVAL DIAGRAM**

This technique can be used if an Exhaust Hanger Removal Pliers is not available.

Using a 5/8" open end wrench, slide the wrench up to the rubber isolator, cradling the hanger rod as shown. Next place the flat edge of a pry bar between the wrench and the hanger stop or hanger rod. Then simply rotate the pry bar toward the wrench to remove the rubber isolator.

Note: Using a spray lubricant or soapy water on the hanger rod and the rubber isolator helps removal.

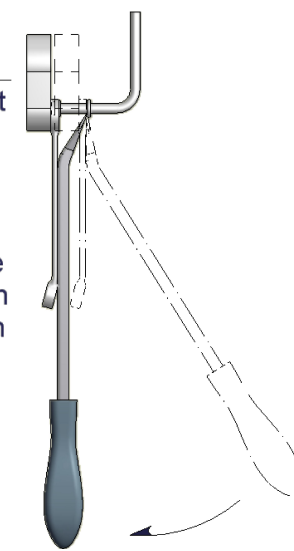

**WELDNUT CLEANING**

To remove debris from weldnuts in frame, spray lubricant or compressed air into hole. For heavy debris, use a small wire brush. (Be careful not to damage threads).

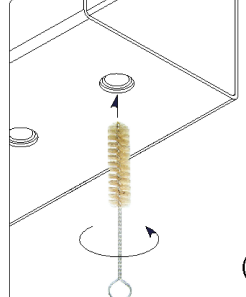
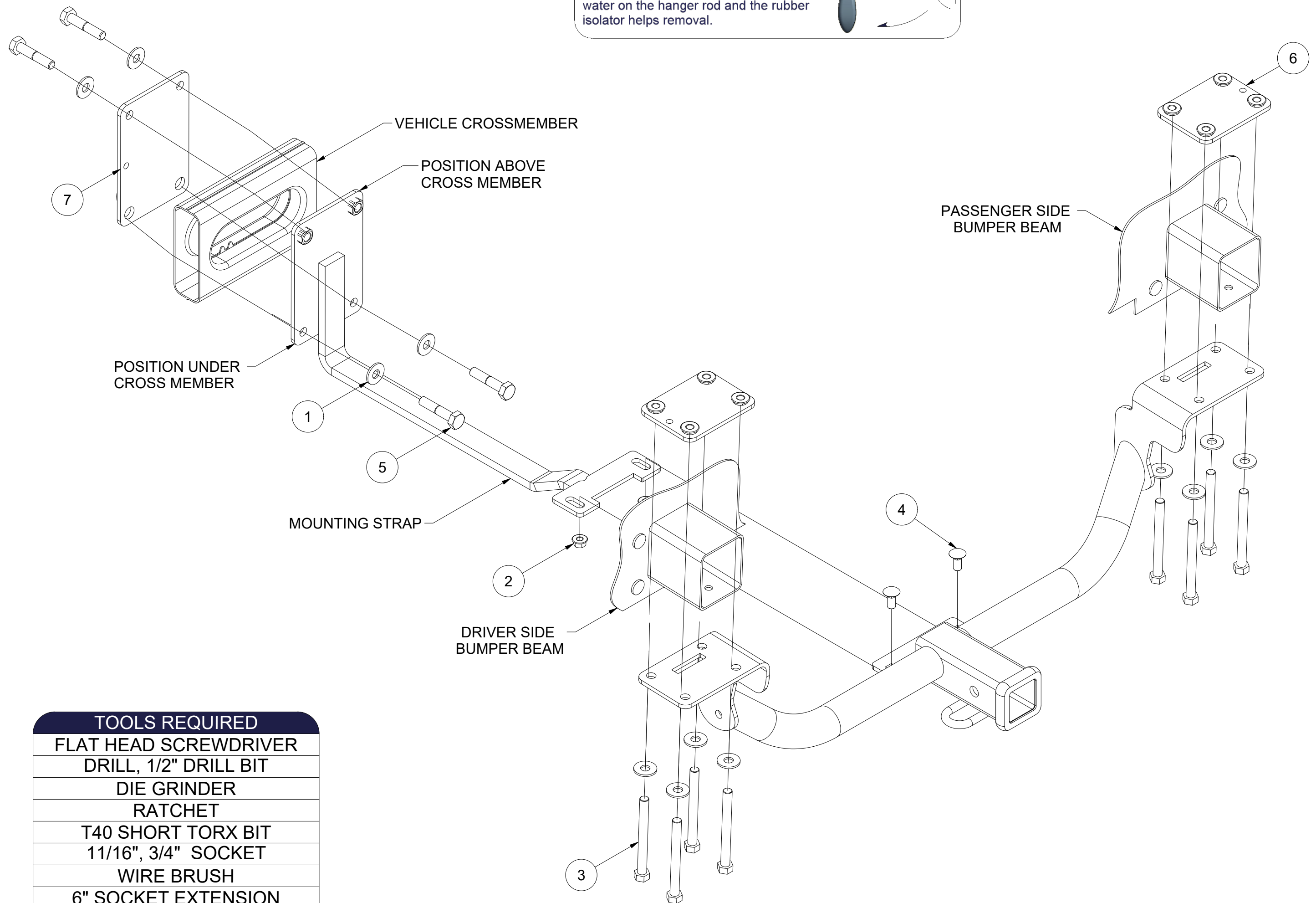
- TOOLS REQUIRED**
- FLAT HEAD SCREWDRIVER
  - DRILL, 1/2" DRILL BIT
  - DIE GRINDER
  - RATCHET
  - T40 SHORT TORX BIT
  - 11/16", 3/4" SOCKET
  - WIRE BRUSH
  - 6" SOCKET EXTENSION
  - TORQUE WRENCH

HITCH WEIGHT: 33 LBS.  
 INSTALL TIME  
 PROFESSIONAL: 45 MINUTES  
 NOVICE (DIY): 90 MINUTES  
 INSTALL NOTES:  
 - LOWER EXHAUST  
 - DRILL ACCESS HOLE

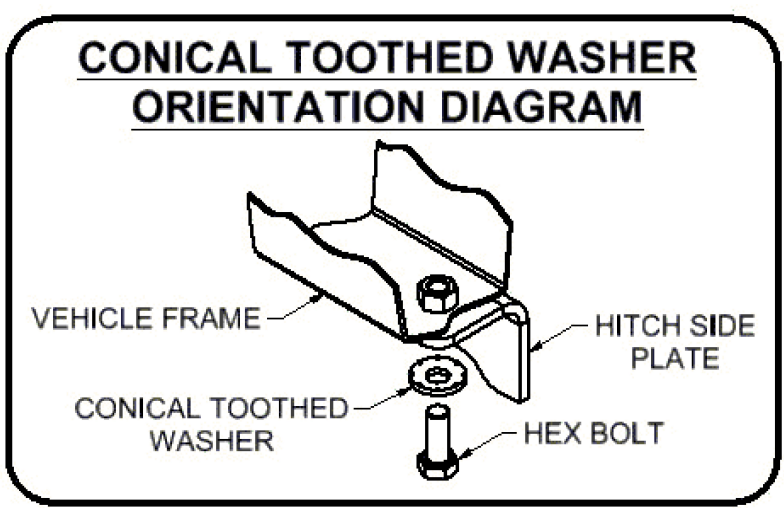

**FRONT**  
**REAR**



**PERIODICALLY CHECK THIS RECEIVER HITCH TO ENSURE THAT ALL FASTENERS ARE TIGHT AND THAT ALL STRUCTURAL COMPONENTS ARE SOUND.**

Curt Manufacturing Inc., warrants this product to be free of defects in material and/or workmanship at the time of retail purchase by the original purchaser. If the product is found to be defective, Curt Manufacturing Inc., may repair or replace the product, at their option, when the product is returned, prepaid, with proof of purchase. Alteration to, misuse of, or improper installation of this product voids the warranty. Curt Manufacturing Inc.'s liability is limited to repair or replacement of products found to be defective, and specifically excludes liability for incidental or consequential loss or damage.



GROSS LOAD CAPACITY WHEN USED AS A WEIGHT CARRYING HITCH: 3,500 LBS. TRAILER WEIGHT & 525 LBS. TONGUE WEIGHT.

**\*\*\*DO NOT EXCEED VEHICLE MANUFACTURER'S RECOMMENDED TOWING CAPACITY.\*\*\***

WARNING: ALL NON-TRAILER LOADS APPLIED TO THIS PRODUCT MUST BE SUPPORTED BY AUXILIARY STABILIZING STRAPS.

**\*\* FAILURE TO PROPERLY SUPPORT NON-TRAILER LOADS WILL VOID PRODUCT WARRANTY\*\***

HAVING INSTALLATION QUESTIONS? CALL TECHNICAL SUPPORT AT 1-877-287-8634

## **INSTALLATION STEPS**

1. Remove 3 fascia clips from each side of the vehicle with a flat head screwdriver. This will allow the fascia to flex slightly for socket access during installation.
2. Remove exhaust tips by removing T40 torx screws from 3 locations on each side of the vehicle with a short torx bit and ratchet extension. Tips will be reinstalled when hitch installation is complete.
3. Lower exhaust by removing (2) isolators on the driver side muffler, (2) isolators on the passenger side muffler, and (2) isolators forward of the mufflers.  
(See RUBBER ISOLATOR REMOVAL DIAGRAM.)  
Note: Exhaust can pivot on driver side at ball joint location for increased access to rear vehicle mounting location.
4. Locate plastic fascia support webbing and drill out center inboard section. Enlarge section for 3/4" socket access in order to tighten hitch to nut plates over bumper beam.
5. Locate supplied nut plates from hitch and hardware assembly. Nut plate weldnut threads may need to be cleaned with a wire brush before assembly. (See WELDNUT CLEANING DIAGRAM.)
6. Place supplied nut plates over bumper beam, as shown.
7. Raise hitch into position over exhaust.
8. Secure hitch to nut plates, with finger tightened 1/2" x 5" hex bolts and 1/2" conical toothed washers, as shown. (Note: Be sure to slide hitch as far forward as possible but not so it rests on the weld seam on the vehicle bumper beams.)
9. Raise mounting strap behind vehicle crossmember, as shown.
10. Secure mounting strap to hitch with finger tightened 7/16" hex flange nuts, as shown.
11. Raise nut plate in front of vehicle crossmember.
12. Secure nut plate to mounting strap with finger tightened 1/2" x 2 1/2" hex bolts and 1/2" conical toothed washers, as shown.
13. Torque all 1/2-13 hex bolts to 75 lb-ft. Torque all 7/16" hardware to 59 lb-ft.
14. Raise exhaust back into position.
15. Reattach fascia screws (3 locations each side of vehicle.)
16. Reattach exhaust tips (3 mounting locations each side of vehicle.)

**PERIODICALLY CHECK THIS RECEIVER HITCH TO ENSURE THAT ALL FASTENERS ARE TIGHT AND THAT ALL STRUCTURAL COMPONENTS ARE SOUND.**