

11188

AUDI A5 (EXCLUDES MODELS WITH SINGLE MUFFLER)

10/1/2020

PAGE 1 of 2

GROSS LOAD CAPACITY WHEN USED AS A WEIGHT CARRYING HITCH: 2,000 LBS. TRAILER WEIGHT & 200 LBS. TONGUE WEIGHT.

DO NOT EXCEED VEHICLE MANUFACTURER'S RECOMMENDED TOWING CAPACITY.

WARNING: ALL NON-TRAILER LOADS APPLIED TO THIS PRODUCT MUST BE SUPPORTED BY AUXILIARY STABILIZING STRAPS.

** FAILURE TO PROPERLY SUPPORT NON-TRAILER LOADS WILL VOID PRODUCT WARRANTY**

HAVING INSTALLATION QUESTIONS? CALL TECHNICAL SUPPORT AT 877-287-8634

Parts List			
ITEM	QTY	PART NUMBER	DESCRIPTION
1	2	10-10278	BOLT,CAR,1/2-13 UNC,1-1/4,GRD8,YZ
2	4	CM-SP19	.250 x 1.25 x 3.00" SQ. HOLE SPACER
3	2	CM-SP40	.188 x 1.00 x 3.00" SQ. HOLE SPACER
4	4	20-00062	NUT, SER-FLANGE,1/2-13 UNC,GRD8,YZ
5	2	10-10287	BOLT,CAR,1/2-13 UNC,1-1/2,GRD8,YZ
6	2	1_2 FISHWIRE	1/2" FISHWIRE

TOOLS REQUIRED
3/4" SOCKET
10, 13 AND 16MM SOCKETS
12" EXTENSION
RATCHET
TORQUE WRENCH
TIN SNIPS

FRONT
↑
REAR

(T55 TORX, T25 TORX AND SMALL FLATHEAD SCREWDRIVER ARE REQUIRED FOR INSTALL ON CONVERTIBLES)

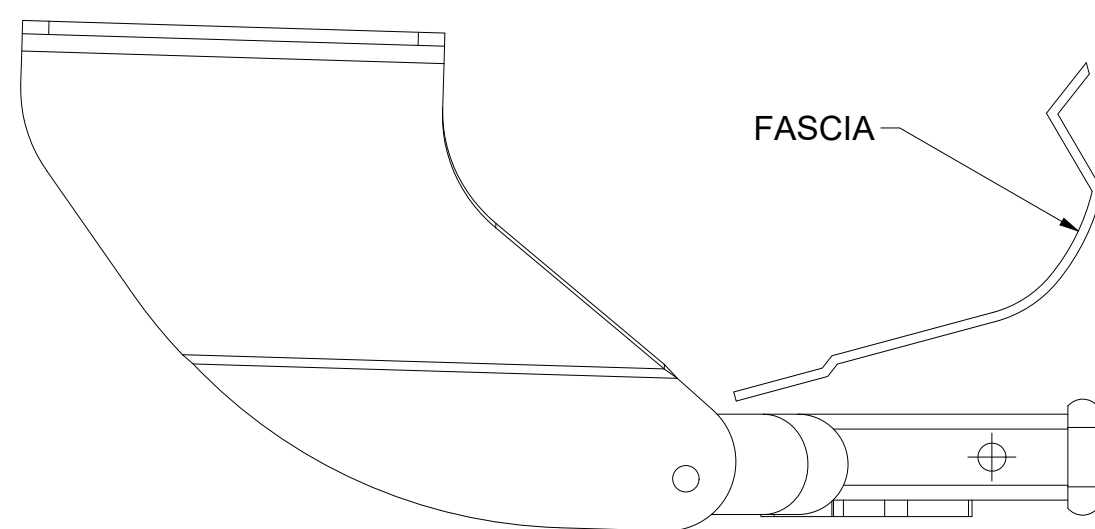
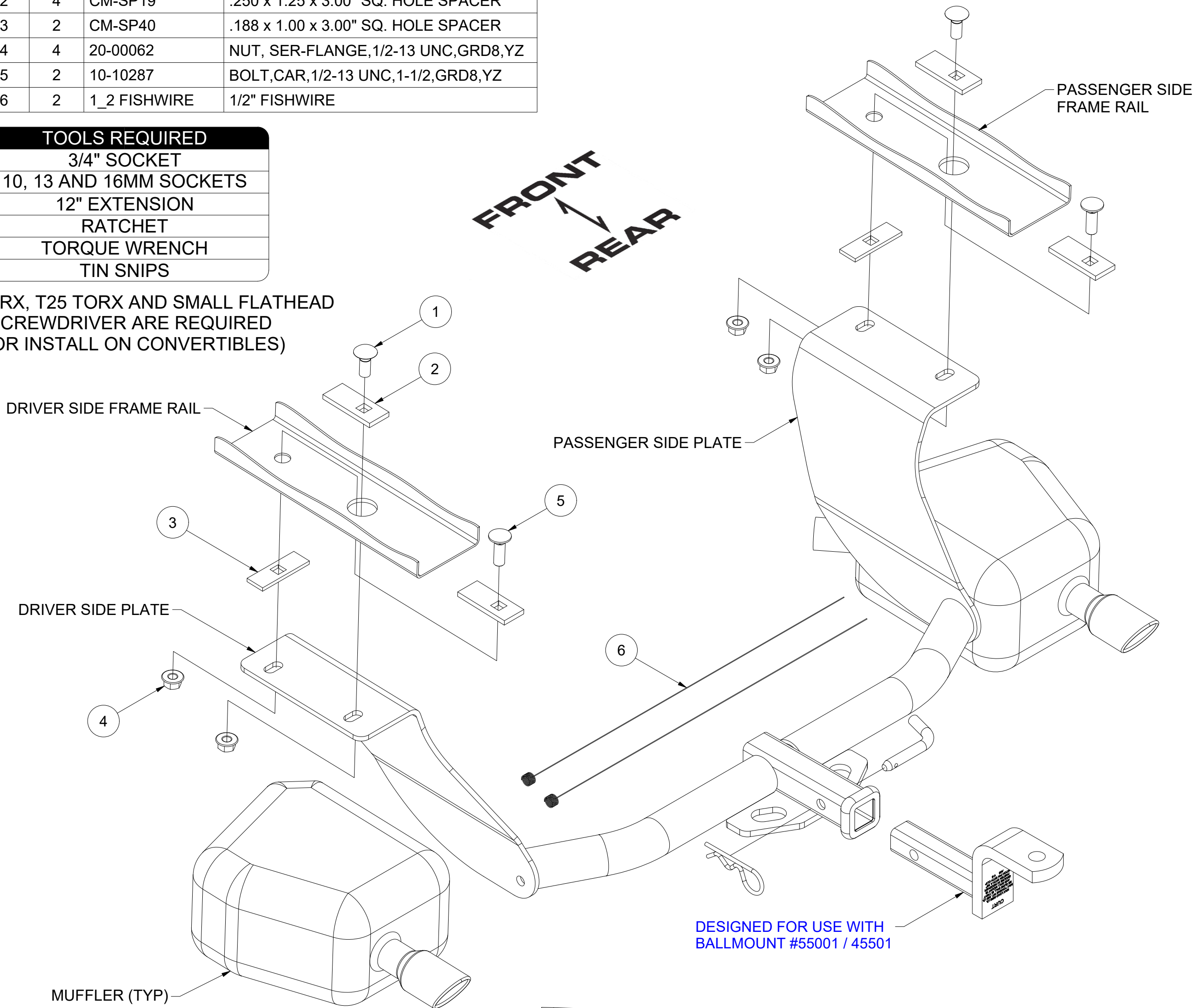

INSTALLED HITCH POSITION

HITCH WEIGHT: 32 LBS.

INSTALL TIME

PROFESSIONAL: 30 MINUTES

NOVICE (DIY): 60 MINUTES

INSTALL NOTES:

- NO DRILLING REQUIRED
- LOWER EXHAUST
- REMOVE AND TRIM EXHAUST HEAT SHIELDS
- FISHWIRE HARDWARE

PERIODICALLY CHECK THIS RECEIVER HITCH TO ENSURE THAT ALL FASTENERS ARE TIGHT AND THAT ALL STRUCTURAL COMPONENTS ARE SOUND.

Curt Manufacturing Inc., warrants this product to be free of defects in material and/or workmanship at the time of retail purchase by the original purchaser. If the product is found to be defective, Curt Manufacturing Inc., may repair or replace the product, at their option, when the product is returned, prepaid, with proof of purchase. Alteration to, misuse of, or improper installation of this product voids the warranty. Curt Manufacturing Inc.'s liability is limited to repair or replacement of products found to be defective, and specifically excludes liability for incidental or consequential loss or damage.

HAVING INSTALLATION QUESTIONS? CALL TECHNICAL SUPPORT AT 877-287-8634



PLASTIC COVER REMOVAL
(CONVERTIBLES ONLY)

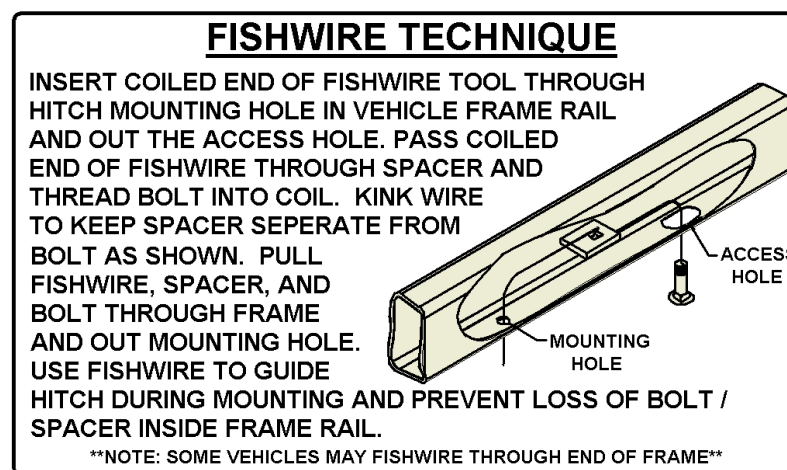

AREA TO TRIM
MUFFLER HEAT SHIELD TRIMMING DIAGRAM

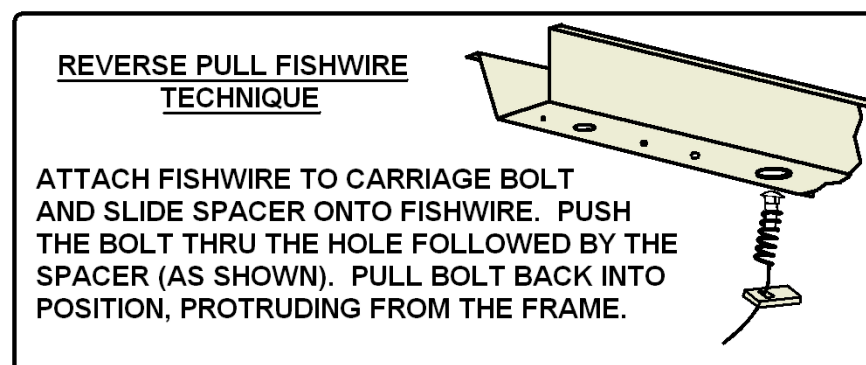

INSTALLATION STEPS

(Note: Steps 1-3 are for convertibles only.)

1. Remove plastic covers covering stabilizer straps on both driver and passenger sides, as shown above. Remove driver side cover by removing (4) screws and (1) plastic push fastener. (**Note:** Plastic push fastener is removed by prying head down with a small screwdriver, pinching opposite end and pushing down through hole.) Remove passenger side cover by removing (2) screws, (2) plastic push fasteners and (1) nut.
2. Remove driver side stabilizer strap by removing (7) torx head bolts. Remove passenger side stabilizer strap by removing (6) torx head bolts.
3. Remove (3) fasteners from rear fascia.
4. Lower the exhaust by removing the (2) nuts securing the rearmost exhaust hanger brackets to the frame rails. (One per side.) Next, remove the cross member under the exhaust by removing the (4) bolts securing it. Lastly, remove the (2) nuts and (2) bolts securing the two exhaust hanger brackets near the cross member. (**Note:** Support the exhaust system to avoid damage.)
5. Remove the muffler heat shields from the vehicle by removing the (8) nuts securing them. Trim the heat shields to allow access to the existing holes in the frame rails. (See Muffler Heat Shield Trimming Diagram.)
6. Reinstall the heat shields removed in Step 3.
7. Fishwire a **1/2-13 x 1 1/2"** carriage bolt and CM-SP19 spacer into each of the forward holes as shown. (See Fishwire Technique.)
8. Reverse pull fishwire a **1/2-13 x 1 1/4"** carriage bolt and CM-SP19 spacer into each of the rearmost holes as shown. (See Reverse Pull Fishwire Technique.)
9. Raise the hitch into position, taking care not to push the fishwired hardware into the frame rails. Place a CM-SP40 between the side plate and frame rail passing the forwardmost bolt through both the spacer and the side plate. Secure the hitch to the frame rails with the hex flange nuts as shown.
10. Torque all 1/2" hardware to 110 ft-lbs.
11. Raise the exhaust into position and reinstall the fasteners for the exhaust hangers and cross member removed in Step 2.

PERIODICALLY CHECK THIS RECEIVER HITCH TO ENSURE THAT ALL FASTENERS ARE TIGHT AND THAT ALL STRUCTURAL COMPONENTS ARE SOUND.