

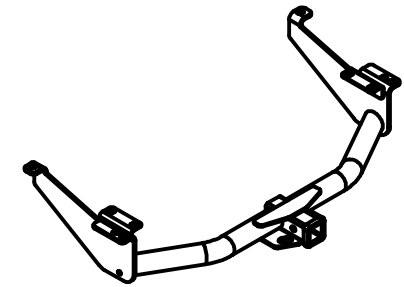

# Class III Receiver Hitch

## Part No. 69610C



**Fits: NISSAN TITAN**



**GROSS LOAD CAPACITY WHEN USED AS A WEIGHT CARRYING HITCH: 8,000 LBS. TRAILER WEIGHT & 800 LBS. TONGUE WEIGHT.  
GROSS LOAD CAPACITY WHEN USED AS A WEIGHT DISTRIBUTION HITCH: 12,000 LBS. TRAILER WEIGHT & 1,200 LBS. TONGUE WEIGHT**



**WARNING: \*\*\* DO NOT EXCEED VEHICLE MANUFACTURER'S RECOMMENDED TOWING CAPACITY. \*\*\***

Parts List			
ITEM	QTY	PART NUMBER	DESCRIPTION
1	10	1/2"	CONICAL TOOTHED WASHER
2	10	M12 - 1.25 x 40 HEX	HEX BOLT

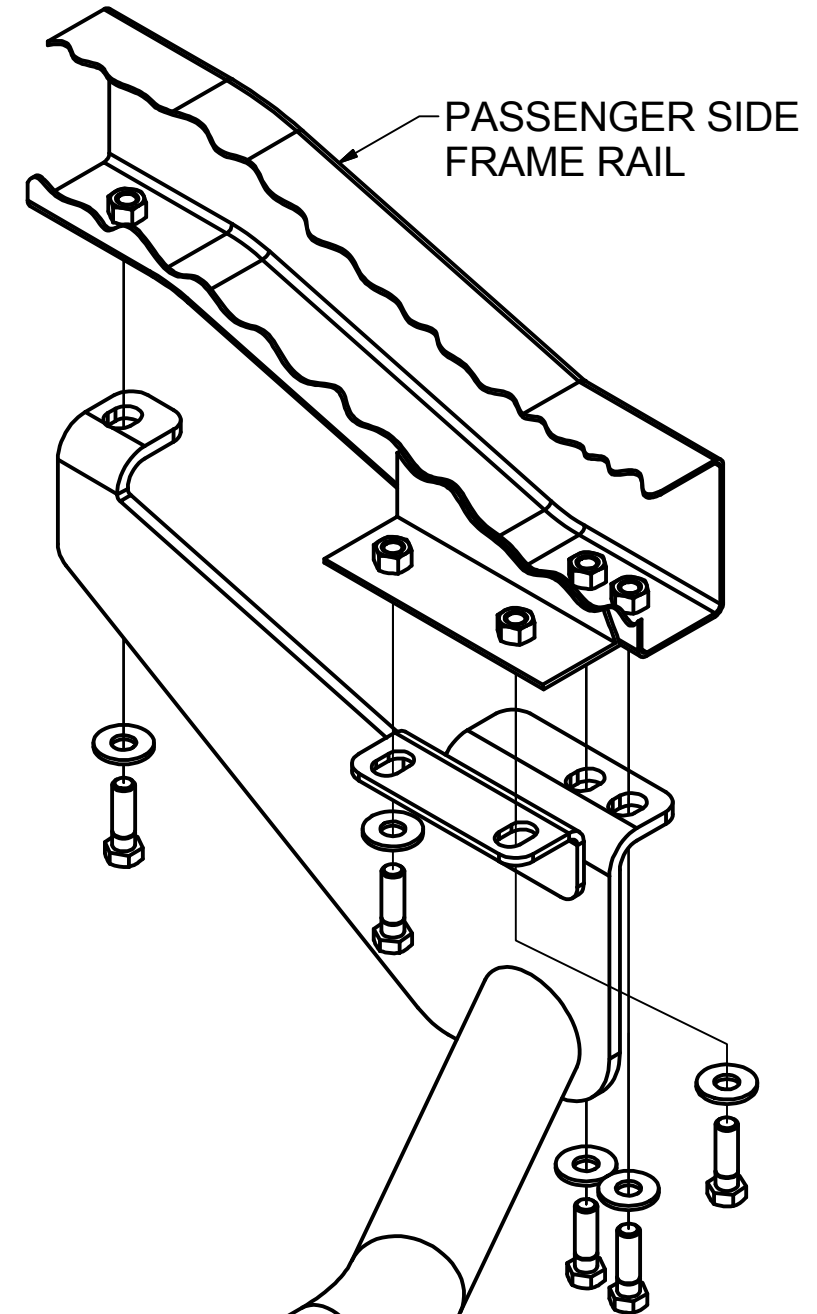
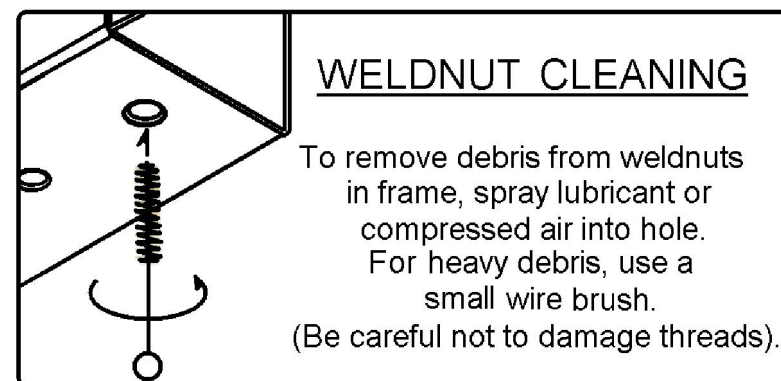
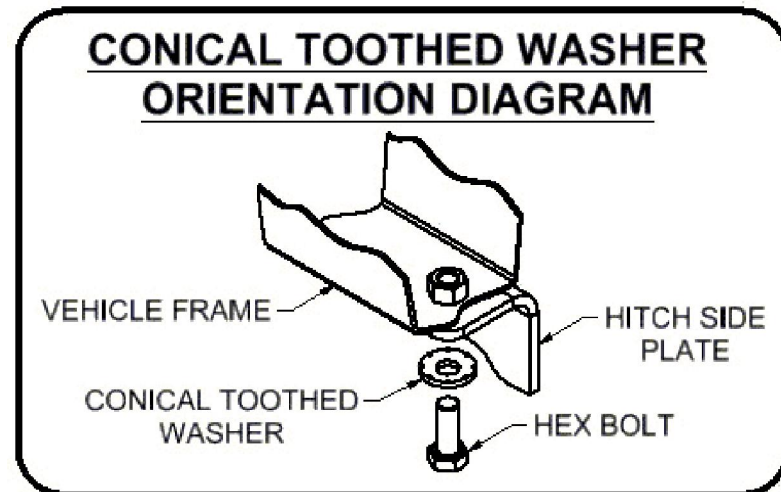

**TOOLS REQUIRED**

17mm & 19mm SOCKETS
RATCHET
TORQUE WRENCH
SAFETY GLASSES

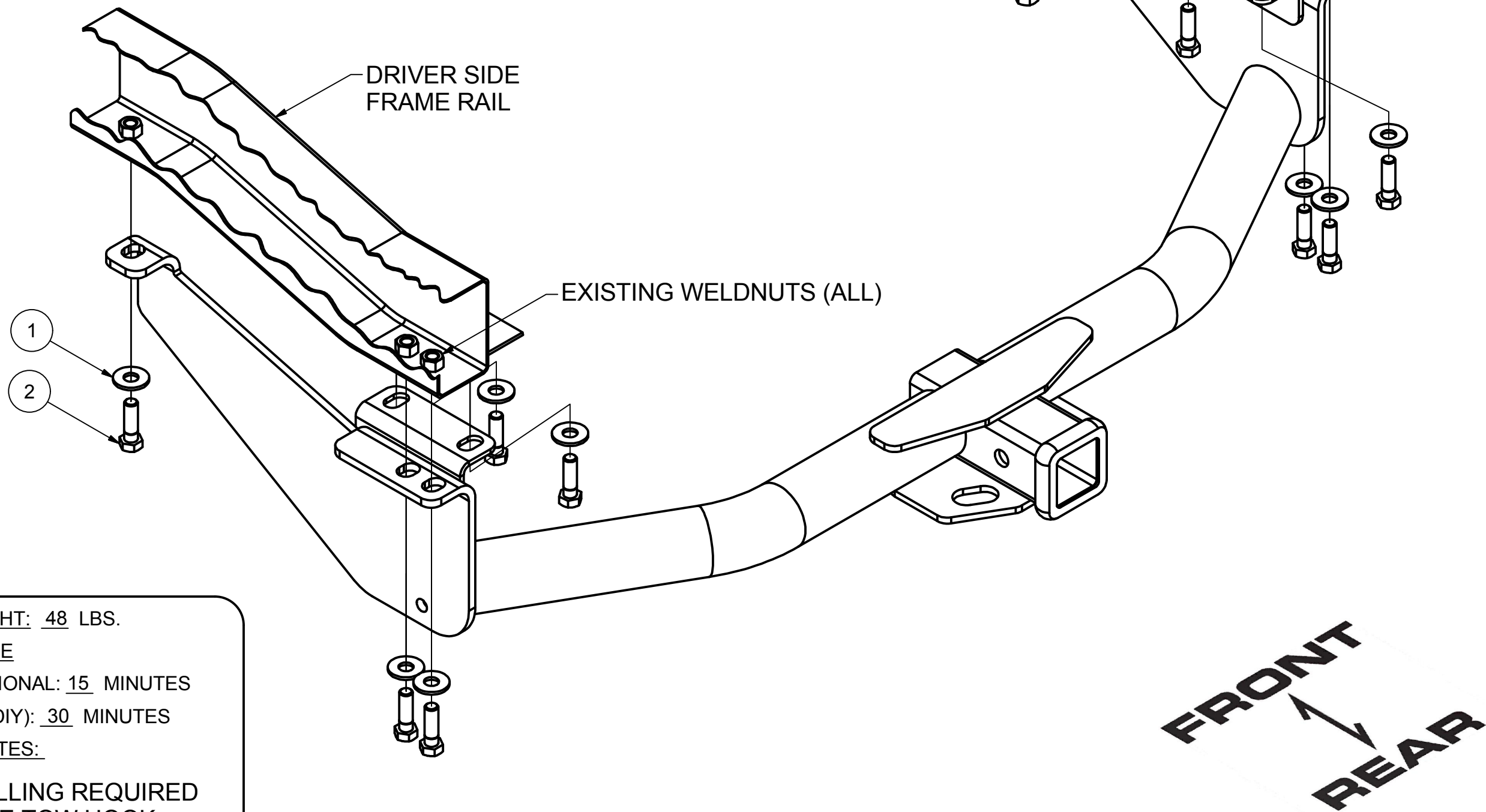

HITCH WEIGHT: 48 LBS.

**INSTALL TIME**

PROFESSIONAL: 15 MINUTES

NOVICE (DIY): 30 MINUTES

**INSTALL NOTES:**

- NO DRILLING REQUIRED
- REMOVE TOW HOOK

### INSTALLATION STEPS

1. If present on vehicle remove tow hooks before installing hitch. Return hooks and hardware to vehicle owner.
2. Raise hitch into position. Fasten hitch by threading (10) M12 x 40mm bolts with conical washers into existing weld nuts, as shown above.
3. Torque 12mm fasteners to 86 lb-ft.

**PERIODICALLY CHECK THIS RECEIVER HITCH TO ENSURE THAT ALL FASTENERS ARE TIGHT AND THAT ALL STRUCTURAL COMPONENTS ARE SOUND.**