

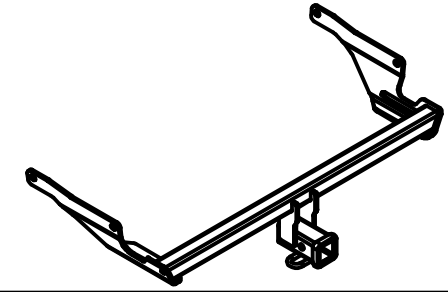

# Class III Receiver Hitch

## Part No. 69602C



**Fits: MAZDA CX-5**



GROSS LOAD CAPACITY WHEN USED AS A WEIGHT CARRYING HITCH: 4,000 LBS. TRAILER WEIGHT & 600 LBS. TONGUE WEIGHT.

**WARNING: \*\*\* DO NOT EXCEED VEHICLE MANUFACTURER'S RECOMMENDED TOWING CAPACITY. \*\*\***



Parts List			
ITEM	QTY	PART NUMBER	DESCRIPTION
1	3	M12 - 1.25 x 40 HEX	HEX BOLT
2	3	1/2 CONICAL TOOTHED WASHER	WASHER, CONICAL, TOOTHED, 1/2"
3	4	FW12	FW, 12, ZP
4	2	1/2-13 x 1 1/2	CARRIAGE BOLT
5	2	CM-SP12	.250 x 1.00 x 2.00" SQUARE HOLE SPACER
6	2	HFN 1213, GR8	HEX FLANGE NUT
7	2	1_2 FISHWIRE	1/2" FISHWIRE
8	2	600043	CABLE TIE 3/16 X 8" 50# UV BLACK

BE SURE TEETH ON ALL CONICAL WASHERS ARE AGAINST THE HITCH

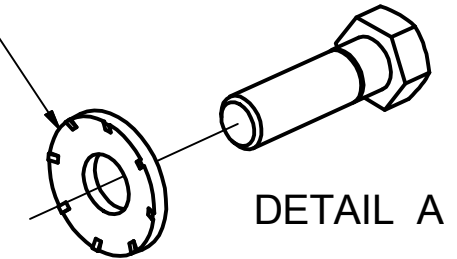

**FISHWIRE TECHNIQUE**  
 INSERT COILED END OF FISHWIRE TOOL THROUGH HITCH MOUNTING HOLE IN VEHICLE FRAME RAIL AND OUT THE ACCESS HOLE. PASS COILED END OF FISHWIRE THROUGH SPACER AND THREAD BOLT INTO COIL. KINK WIRE TO KEEP SPACER SEPARATE FROM BOLT AS SHOWN. PULL FISHWIRE, SPACER, AND BOLT THROUGH FRAME AND OUT MOUNTING HOLE. USE FISHWIRE TO GUIDE HITCH DURING MOUNTING AND PREVENT LOSS OF BOLT / SPACER INSIDE FRAME RAIL.  
 \*\*NOTE: SOME VEHICLES MAY FISHWIRE THROUGH END OF FRAME\*\*

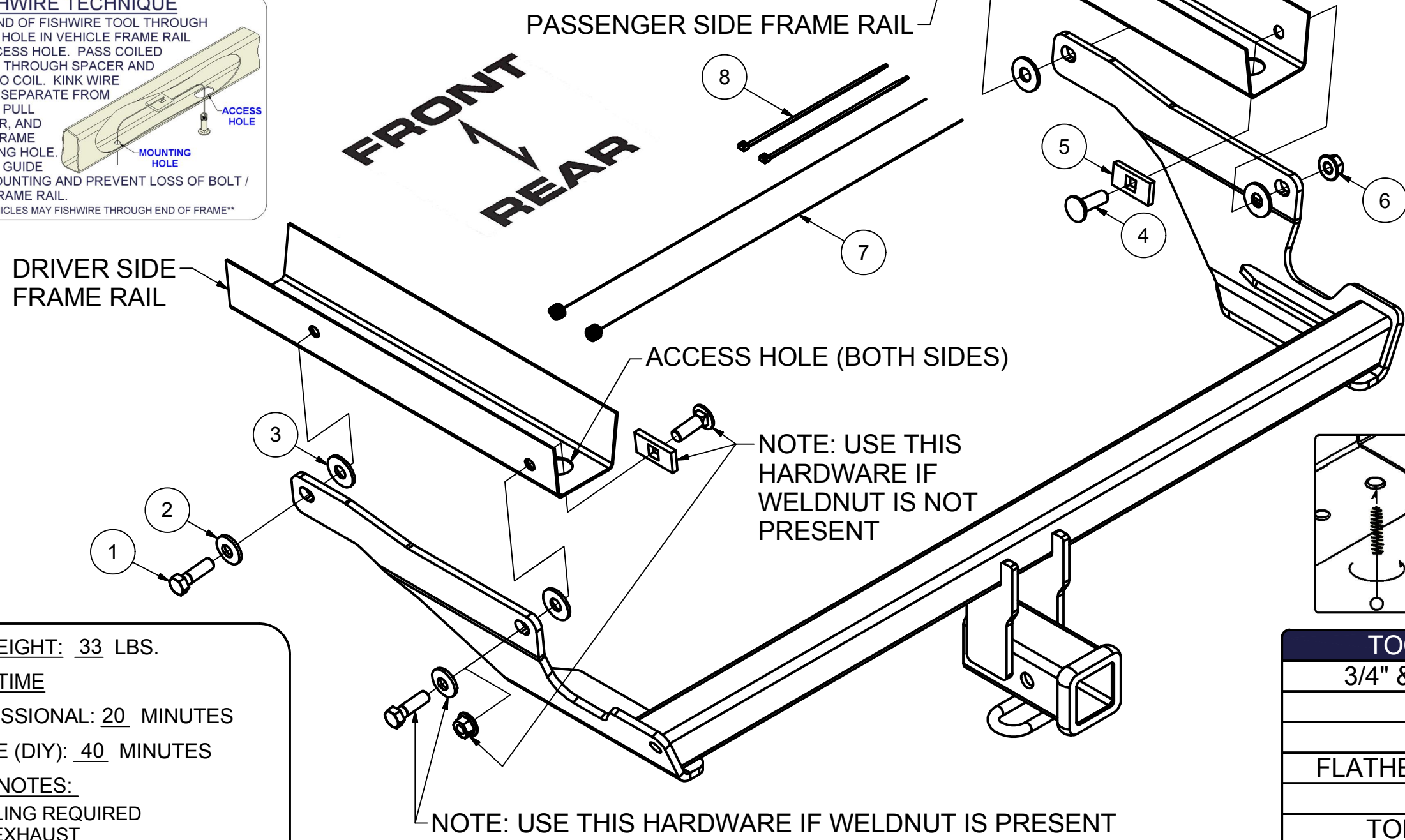
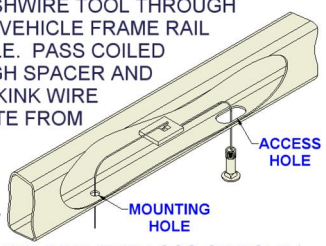

NOTE: USE THIS HARDWARE IF WELDNUT IS NOT PRESENT

NOTE: USE THIS HARDWARE IF WELDNUT IS PRESENT

**WELDNUT CLEANING**  
 To remove debris from weldnuts in frame, spray lubricant or compressed air into hole. For heavy debris, use a small wire brush. (Be careful not to damage threads).

TOOLS REQUIRED
3/4" & 19mm SOCKETS
RATCHET
TAPE
FLATHEAD SCREWDRIVER
PLIERS
TORQUE WRENCH
PRY BAR
SAFETY GLASSES

**HITCH WEIGHT:** 33 LBS.  
**INSTALL TIME**  
 PROFESSIONAL: 20 MINUTES  
 NOVICE (DIY): 40 MINUTES  
**INSTALL NOTES:**  
 -NO DRILLING REQUIRED  
 -LOWER EXHAUST  
 -FISHWIRE HARDWARE  
 -REMOVE PLASTIC PANEL (IF PRESENT)  
 -MAY REQUIRE WELD NUT CLEANING

### INSTALLATION STEPS

1. Remove plastic underbody panel under rear bumper (if present) by removing two plastic fasteners with a flat head screwdriver. Return panel & fasteners to vehicle owner.
2. Remove tape on the side of vehicle frame rails to expose mounting locations. Trim any excess seam seal (if it will interfere with hitch).
3. Remove plastic insert (if present) &/or electrical harness clip between hitch mounting locations on passenger side frame rail. Unfasten electrical harness clip on outside of the driver side frame rail & follow harness to unfasten nearest clip towards center of vehicle.
4. Lower exhaust by removing two to four (depending on vehicle) rearmost rubber hangers. Leave rubber hangers attached to the vehicle.
5. To ease installation tape four 1/2" flat washers into position on the inside of hitch side plates.
6. Fishwire 1/2" carriage bolt with CM-SP12 spacer in through access hole and out rearmost mounting location in the passenger frame rail. Repeat on rearmost mounting location in driver side frame rail (if there is no weldnut in frame). Leave hardware fully inside of frame rail(s) with fishwire(s) attached. See FISHWIRE TECHNIQUE diagram above.
7. Thread fishwire(s) through rearmost hitch mounting holes. Pull bumper fascia rearward and exhaust downward to get hitch into position.
8. Insert M12 bolts with conical toothed washers. Be sure the tooth side of washers are against the hitch and the 1/2" flat washers clamped in position between the hitch and frame rail.
9. Pull 1/2" hardware into position & remove fishwire(s). Fasten with 1/2" hex flange nut(s). Re-secure harness which was unfastened in step 3. Wrap cable tie(s) around hitch mounting plate(s) and harness. Pull tight & trim excess cable tie.
10. Torque all M12 hardware to 86.2 ft-lbs & 1/2" hardware to 110 ft-lbs.

**PERIODICALLY CHECK THIS RECEIVER HITCH TO ENSURE THAT ALL FASTENERS ARE TIGHT AND THAT ALL STRUCTURAL COMPONENTS ARE SOUND.**

Keystone Automotive Operations Inc., warrants this product to be free of defects in material and/or workmanship at the time of retail purchase by the original purchaser. If the product is found to be defective, Keystone Automotive Operations Inc., may repair or replace the product, at their option, when the product is returned, prepaid, with proof of purchase. Alteration to, misuse of, or improper installation of this product voids the warranty. Keystone Automotive Operations Inc.'s liability is limited to repair or replacement of products found to be defective, and specifically excludes liability for incidental or consequential loss or damage. This product complies with safety specifications and requirements for connecting devices and towing systems of the state of New York, V.E.S.C. Regulation V-5 and SAE J684. For Technical & Warranty Support: 1-877-544-4449 Fax- 1-855-242-8922 [www.huskytow.com](http://www.huskytow.com) **11202017**