

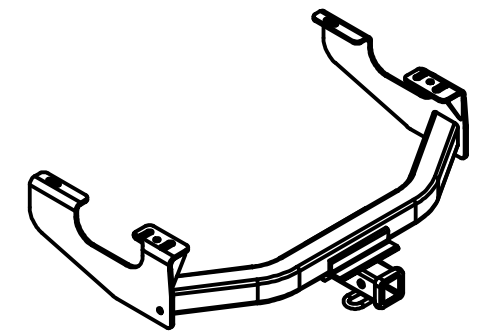

Class III Receiver Hitch

Part No. 69601C



Fits: 97-03 FORD F-150 / 250LD (NEW BODY STYLE)
99-CURRENT FORD F-250 / 350 SUPER DUTY
2008-CURRENT FORD F-450 SUPER DUTY

FITS 20" SPARE TIRE



GROSS LOAD CAPACITY WHEN USED AS A WEIGHT CARRYING HITCH: 6,000 LBS. TRAILER WEIGHT & 600 LBS. TONGUE WEIGHT.
GROSS LOAD CAPACITY WHEN USED AS A WEIGHT DISTRIBUTION HITCH: 10,000 LBS. TRAILER WEIGHT & 1,000 LBS. TONGUE WEIGHT

WARNING: * DO NOT EXCEED VEHICLE MANUFACTURER'S RECOMMENDED TOWING CAPACITY. *****



Parts List			
ITEM	QTY	PART NUMBER	DESCRIPTION
1	6	1/2-13 x 1 3/4	CARRIAGE BOLT
2	6	CM-SP1	.250 x 1.50 x 2.00" SQUARE HOLE SPACER
3	6	HFN 1213	HEX FLANGE NUT

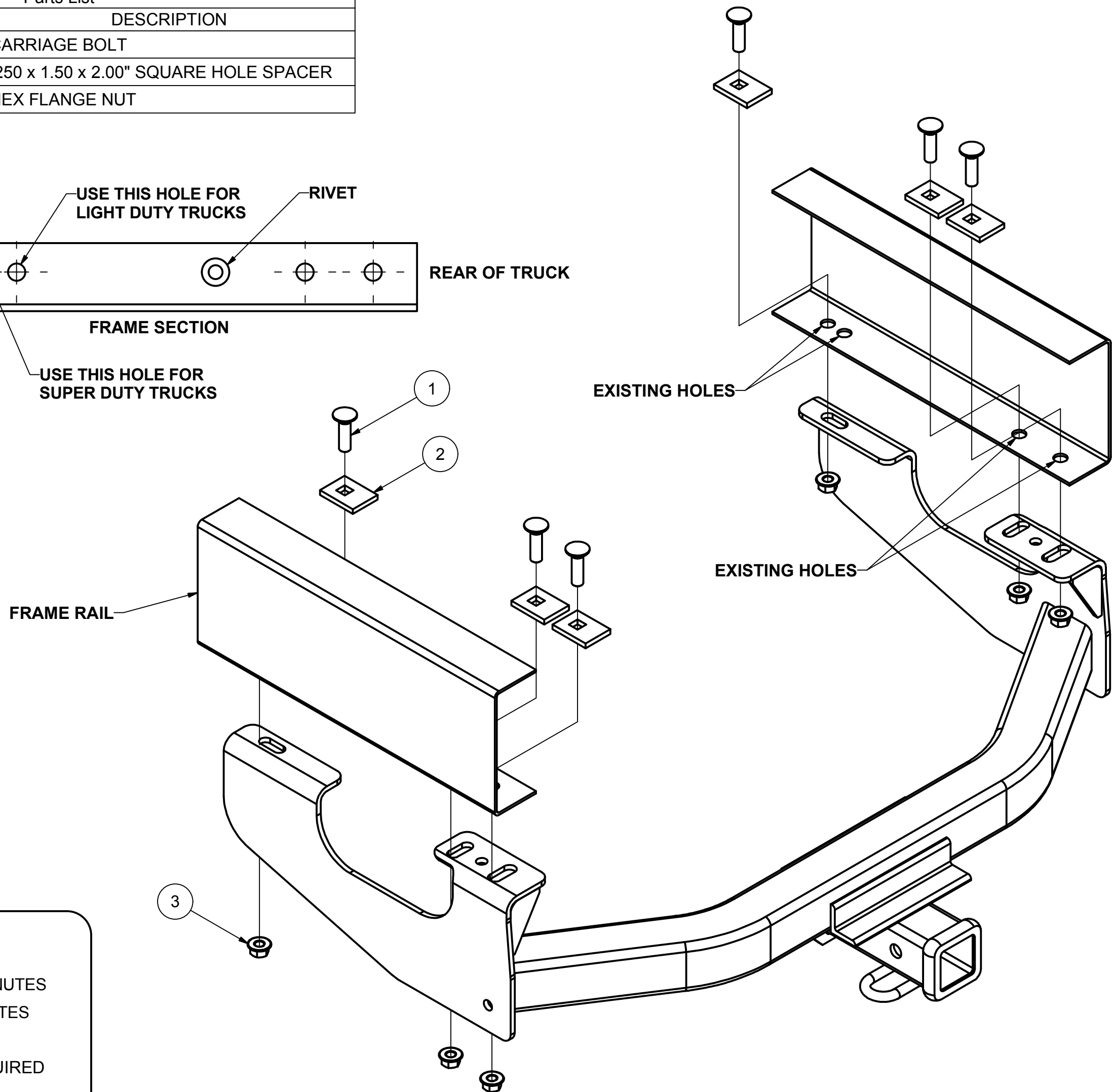
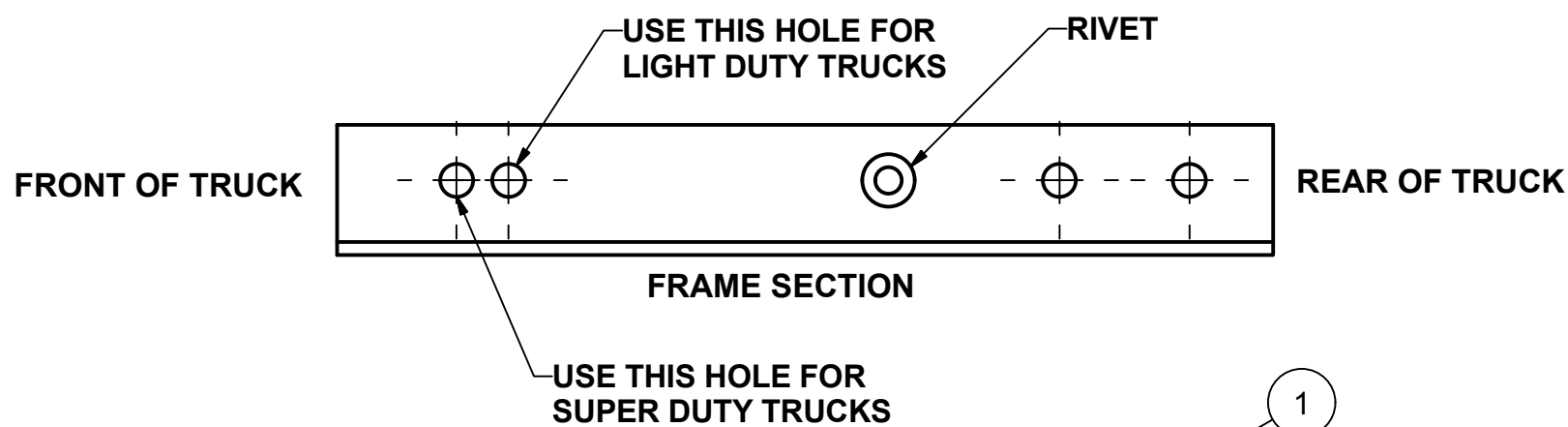

HITCH WEIGHT: 43 LBS.

INSTALL TIME

PROFESSIONAL: 15 MINUTES

NOVICE (DIY): 30 MINUTES

INSTALL NOTES:

- NO DRILLING REQUIRED
- LOWER SPARE

INSTALLATION STEPS

- 1) Lower the spare for ease of installation. (Spare will be replaced after hitch is installed.)
- 2) Install 1/2" carriage bolts and spacers through existing holes in frame as shown.
- 3) Raise hitch into position over carriage bolts and secure with flange nuts as shown. Be sure the wire harness, near the end of the truck frame is not pinched between the hitch and frame.
(Note: Only one of the two holes toward the front of the truck will be used in the side plates.)
- 4) Torque all 1/2" fasteners to 110 lb.-ft.
- 5) Raise spare tire back into its storage location under truck.
(Note: Spare may need to be pushed toward front of truck to provide clearance between tire and hitch.)

PERIODICALLY CHECK THIS RECEIVER HITCH TO ENSURE THAT ALL FASTENERS ARE TIGHT AND THAT ALL STRUCTURAL COMPONENTS ARE SOUND.

Keystone Automotive Operations Inc., warrants this product to be free of defects in material and/or workmanship at the time of retail purchase by the original purchaser. If the product is found to be defective, Keystone Automotive Operations Inc., may repair or replace the product, at their option, when the product is returned, prepaid, with proof of purchase. Alteration to, misuse of, or improper installation of this product voids the warranty. Keystone Automotive Operations Inc.'s liability is limited to repair or replacement of products found to be defective, and specifically excludes liability for incidental or consequential loss or damage. This product complies with safety specifications and requirements for connecting devices and towing systems of the state of New York, V.E.S.C. Regulation V-5 and SAE J684. For Technical & Warranty Support: 1-877-544-4449 Fax- 1-855-242-8922 www.huskytow.com

11202017