

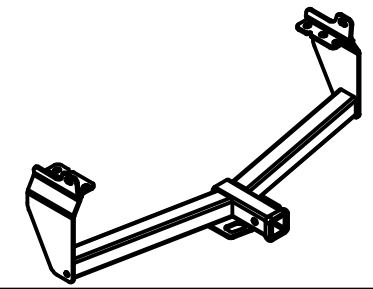

Class III Receiver Hitch

Part No. 69595C



Fits: JEEP CHEROKEE (ALL MODELS INCLUDING TRAILHAWK)



**GROSS LOAD CAPACITY WHEN USED AS A WEIGHT CARRYING HITCH: 5,000 LBS. TRAILER WEIGHT & 750 LBS. TONGUE WEIGHT.
GROSS LOAD CAPACITY WHEN USED AS A WEIGHT DISTRIBUTION HITCH: 6,000 LBS. TRAILER WEIGHT & 750 LBS. TONGUE WEIGHT**

WARNING: * DO NOT EXCEED VEHICLE MANUFACTURER'S RECOMMENDED TOWING CAPACITY. *****



Parts List			
ITEM	QTY	PART NUMBER	DESCRIPTION
1	6	HFN 1213, GR8	HEX FLANGE NUT
2	6	1/2-13 x 1 1/2, GR8	CARRIAGE BOLT
3	6	1_2 FISHWIRE	1/2" FISHWIRE
4	6	CM-SP6	.250 x 1.00 x 3.00" SQUARE HOLE SPACER

TOOLS REQUIRED
RATCHET
3/4", 8mm, 21mm SOCKET
6" SOCKET EXTENSION
TORQUE WRENCH

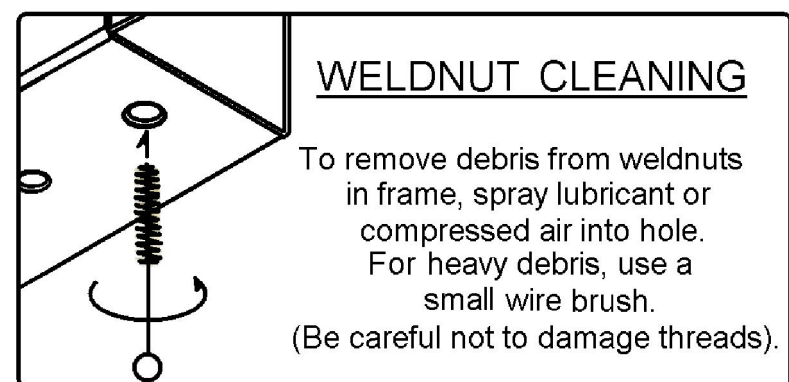
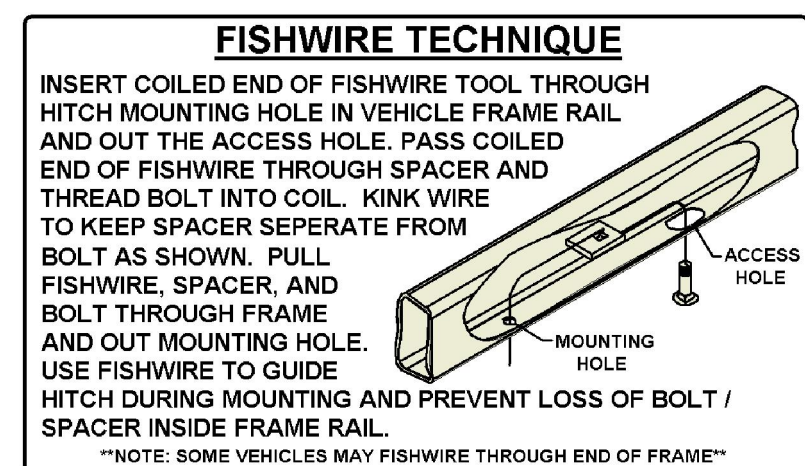
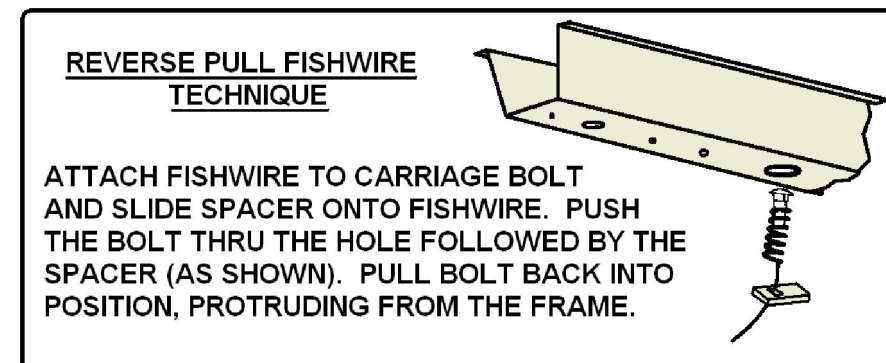

HITCH WEIGHT: 48 LBS.

INSTALL TIME

PROFESSIONAL: 30 MINUTES

NOVICE (DIY): 60 MINUTES

INSTALL NOTES:

- NO DRILLING
- FISHWIRE HARDWARE
- REVERSE FISHWIRE HARDWARE
- TRAILHAWK: TEMP. REMOVE FASCIA

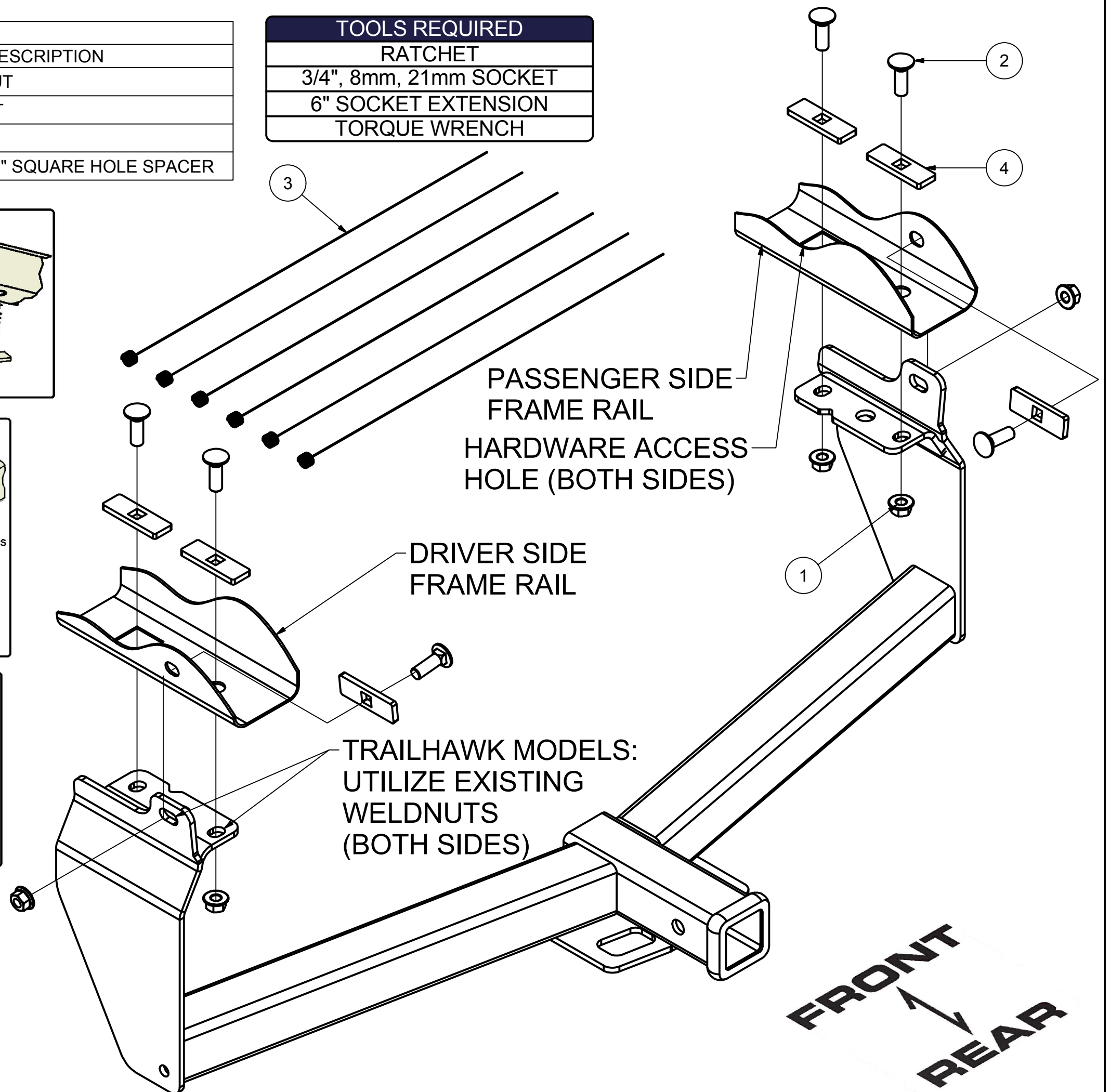

INSTALLATION STEPS

- Trailhawk models: Temporary plastic fascia removal is required for install. Remove (4) screws with a 10mm socket from the bottom of the panel, and push on tabs to unclip. Set aside for reassembly.
- Examine vehicle frame rails - If wire is present on either side frame rail, unfasten by pulling retainer out of the frame and temporarily let hang loose below frame rail. Remove square rubber plug on each side of the frame rails to expose access holes. Return plugs to owner.
- Fishwire rear and side mounting hole hardware through the access hole in the vehicle frame. Reverse fishwire remaining hardware through the access hole (both sides). Trailhawk models: Only use "reverse fishwire hardware" and the vehicle M14 bolts previously removed.
- Raise hitch up from in front of the exhaust and into position, using care not to push hardware back inside frame. Be sure to loosely secure hitch with the mounting hardware to align all holes before tightening. Note: Seam foam may need to be trimmed for proper mounting plate fit.
- As needed, resecure wire to vehicle frame rail. Torque all 1/2" hardware to 110 lb-ft. Trailhawk models: Torque all M14 hardware to 139 lb-ft.
- Trailhawk models: Clip plastic fascia panel into place and secure with (4) screws.

PERIODICALLY CHECK THIS RECEIVER HITCH TO ENSURE THAT ALL FASTENERS ARE TIGHT AND THAT ALL STRUCTURAL COMPONENTS ARE SOUND.

Keystone Automotive Operations Inc., warrants this product to be free of defects in material and/or workmanship at the time of retail purchase by the original purchaser. If the product is found to be defective, Keystone Automotive Operations Inc., may repair or replace the product, at their option, when the product is returned, prepaid, with proof of purchase. Alteration to, misuse of, or improper installation of this product voids the warranty. Keystone Automotive Operations Inc.'s liability is limited to repair or replacement of products found to be defective, and specifically excludes liability for incidental or consequential loss or damage. This product complies with safety specifications and requirements for connecting devices and towing systems of the state of New York, V.E.S.C. Regulation V-5 and SAE J684. For Technical & Warranty Support: 1-877-544-4449 Fax- 1-855-242-8922 www.huskytow.com

11202017