

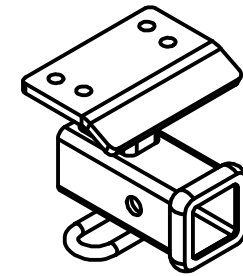

Class III Receiver Hitch

Part No. 69591C



Fits: VOLKSWAGEN TIGUAN



GROSS LOAD CAPACITY WHEN USED AS A WEIGHT CARRYING HITCH: 3,500 LBS. TRAILER WEIGHT & 350 LBS. TONGUE WEIGHT.

WARNING: * DO NOT EXCEED VEHICLE MANUFACTURER'S RECOMMENDED TOWING CAPACITY. *****



Parts List			
ITEM	QTY	PART NUMBER	DESCRIPTION
1	4	M10 - 1.5 x 70 HEX	HEX BOLT
2	4	3/8"	CONICAL TOOTHED WASHER

TOOLS REQUIRED
RATCHET
17mm SOCKET
TORQUE WRENCH
UTILITY KNIFE

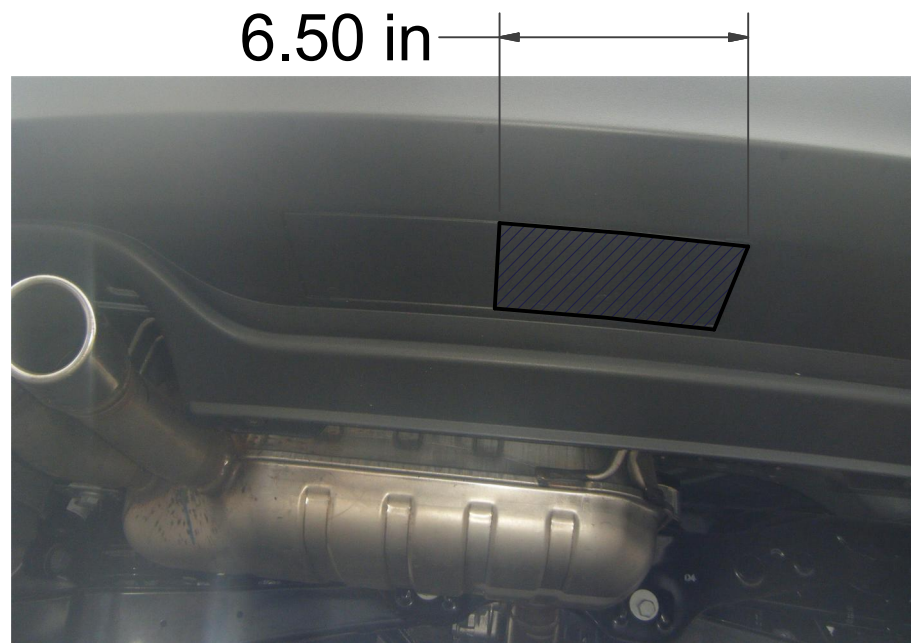

TRIM DIAGRAM

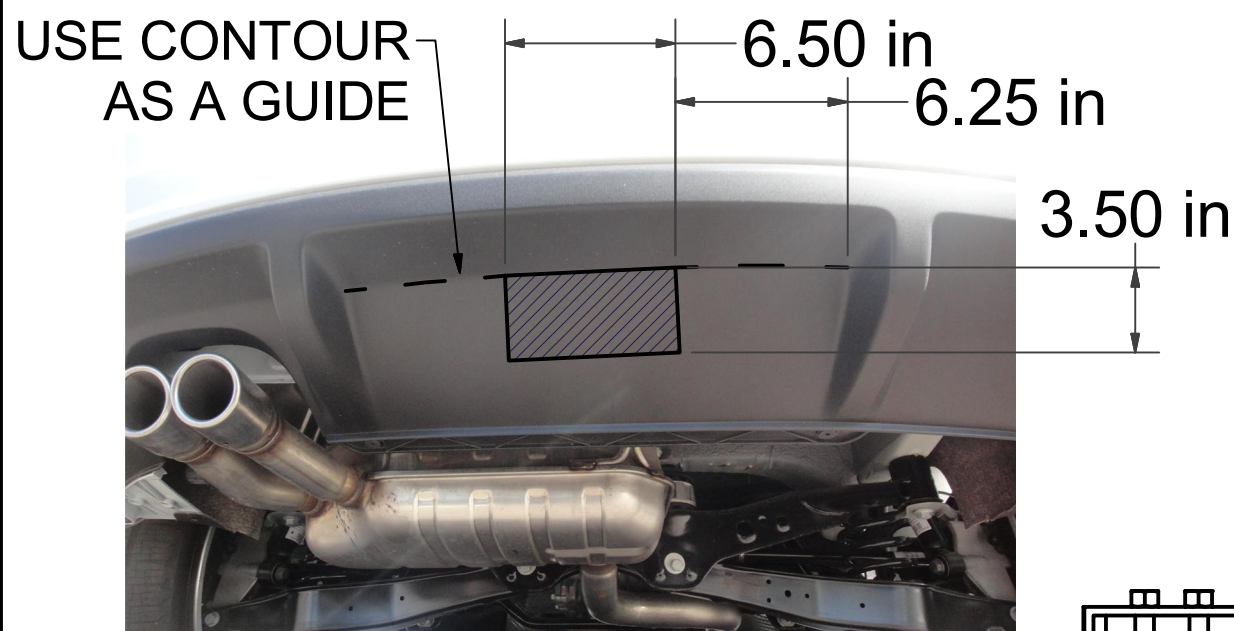

R-LINE TRIM DIAGRAM

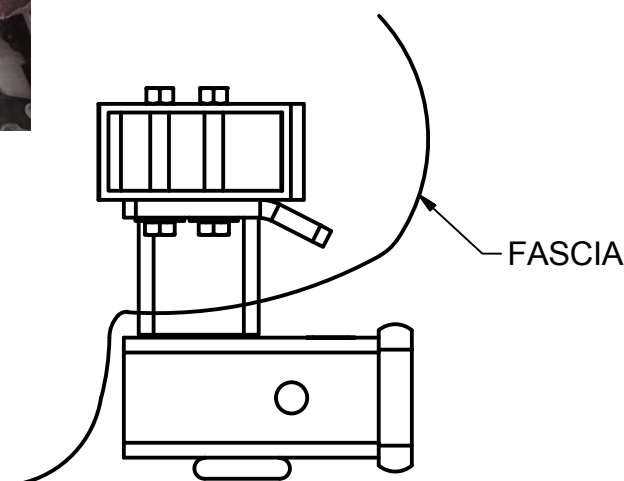

INSTALLED HITCH POSITION

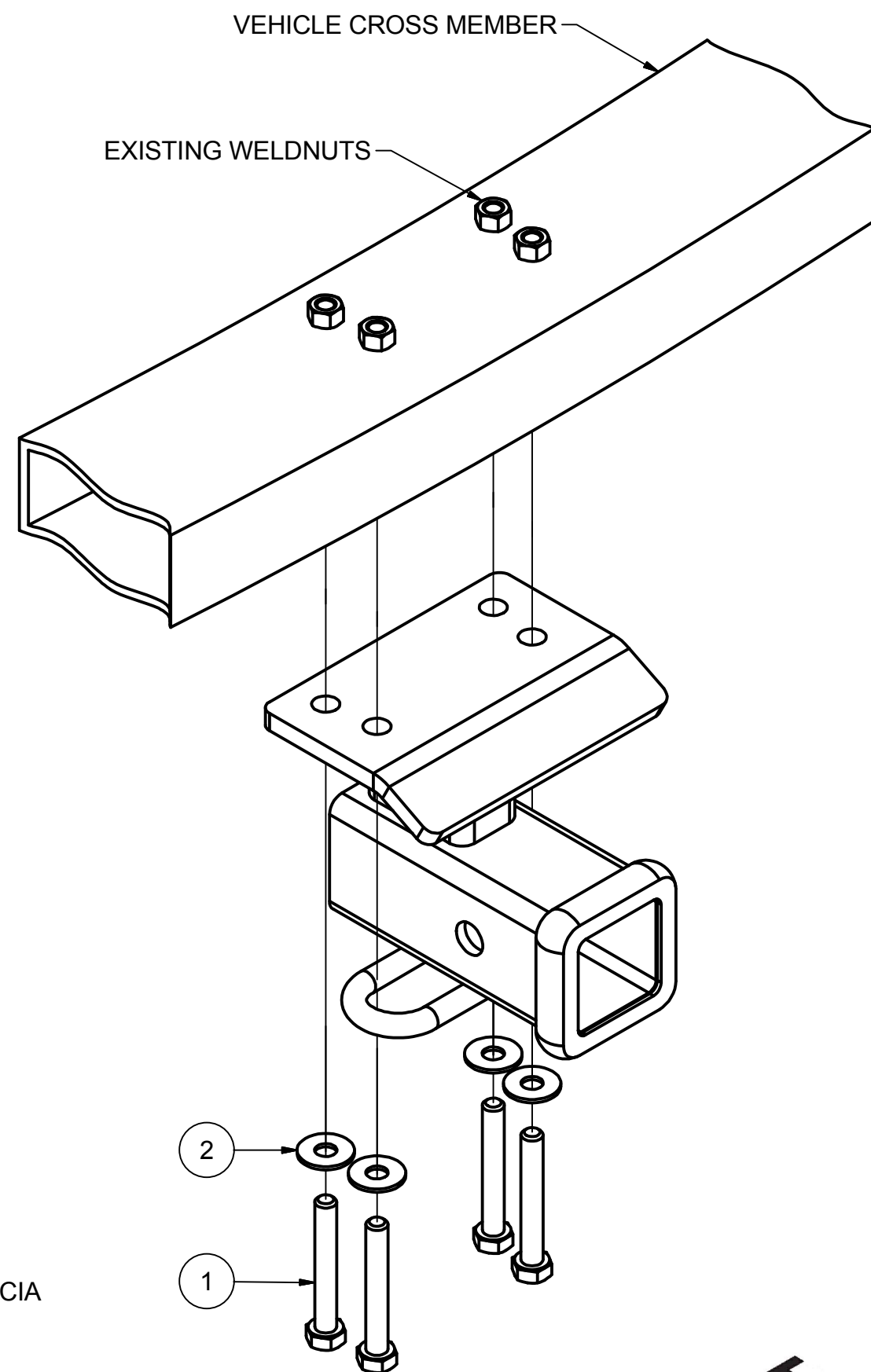

FRONT
↑
REAR

HITCH WEIGHT: 9 LBS.

INSTALL TIME

PROFESSIONAL: 20 MINUTES

NOVICE (DIY): 40 MINUTES

INSTALL NOTES:

- FASCIA TRIMMING
- NO DRILLING

INSTALLATION STEPS

1. Locate existing grooved area on bottom of fascia. Trim fascia as shown in TRIM DIAGRAM. On R-Line models locate contour in bottom of fascia. Trim as shown in R-LINE TRIM DIAGRAM.
2. Raise hitch into position.
3. Attach hitch to vehicle's cross member using the hardware supplied and the vehicle's existing weldnuts.
4. Torque all M10 hardware to 45 ft-lbs.

PERIODICALLY CHECK THIS RECEIVER HITCH TO ENSURE THAT ALL FASTENERS ARE TIGHT AND THAT ALL STRUCTURAL COMPONENTS ARE SOUND.

Keystone Automotive Operations Inc., warrants this product to be free of defects in material and/or workmanship at the time of retail purchase by the original purchaser. If the product is found to be defective, Keystone Automotive Operations Inc., may repair or replace the product, at their option, when the product is returned, prepaid, with proof of purchase. Alteration to, misuse of, or improper installation of this product voids the warranty. Keystone Automotive Operations Inc.'s liability is limited to repair or replacement of products found to be defective, and specifically excludes liability for incidental or consequential loss or damage. This product complies with safety specifications and requirements for connecting devices and towing systems of the state of New York, V.E.S.C. Regulation V-5 and SAE J684. For Technical & Warranty Support: 1-877-544-4449 Fax- 1-855-242-8922 www.huskytow.com

11202017