

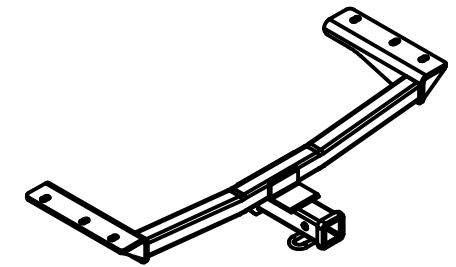

Class III Receiver Hitch

Part No. 69584C



Fits: **LEXUS RX350**



GROSS LOAD CAPACITY WHEN USED AS A WEIGHT CARRYING HITCH: 4,000 LBS. TRAILER WEIGHT & 600 LBS. TONGUE WEIGHT.
GROSS LOAD CAPACITY WHEN USED AS A WEIGHT DISTRIBUTION HITCH: 5,000 LBS. TRAILER WEIGHT & 600 LBS. TONGUE WEIGHT

WARNING: * DO NOT EXCEED VEHICLE MANUFACTURER'S RECOMMENDED TOWING CAPACITY. *****



Parts List			
ITEM	QTY	PART NUMBER	DESCRIPTION
1	6	M12 - 1.25 x 40 HEX	HEX BOLT
2	6	1/2"	CONICAL TOOTHED WASHER

TOOLS REQUIRED
17mm/19mm SOCKET
6" EXTENSION
RATCHET
TORQUE WRENCH
SCREWDRIVER
SAFETY GLASSES

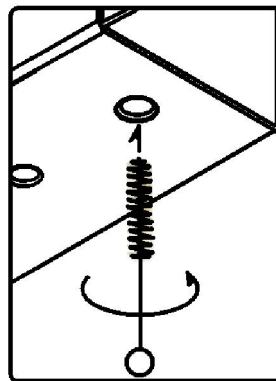

WELDNUT CLEANING

To remove debris from weldnuts in frame, spray lubricant or compressed air into hole. For heavy debris, use a small wire brush. (Be careful not to damage threads).

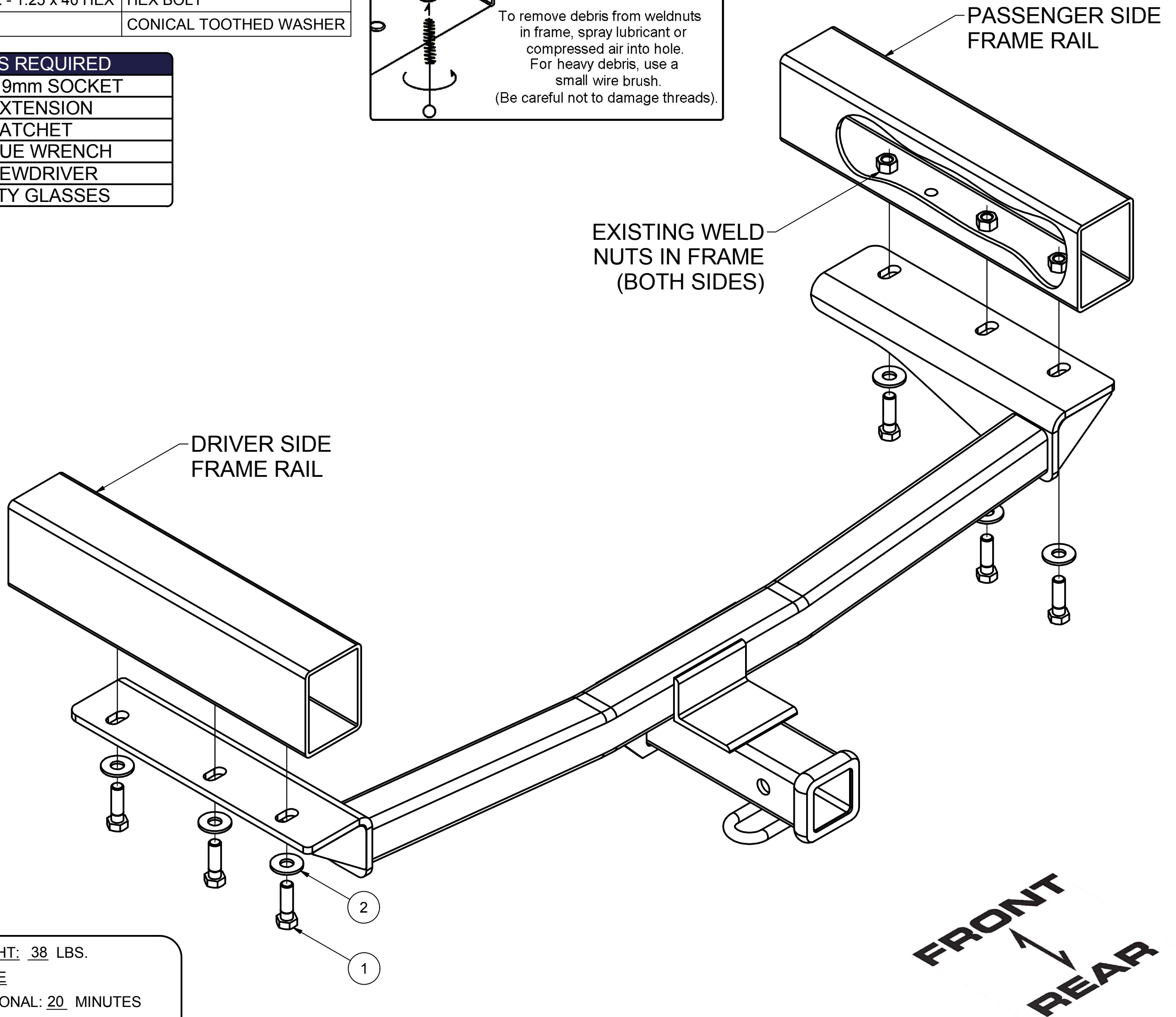

HITCH WEIGHT: 38 LBS.

INSTALL TIME

PROFESSIONAL: 20 MINUTES

NOVICE (DIY): 30 MINUTES

INSTALL NOTES:

- NO DRILLING
- WELDNUT CLEANING

INSTALLATION STEPS

- Using a 17mm socket remove (2) 12mm bolts from tow loop and return to owner. Remove (5) plugs from the bottom of the driver side frame rail and (2) plugs from passenger side of frame rail.
- Raise hitch into position and loosely secure with supplied M12 bolts and conical washers.
- Torque all hardware to 86 ft-lbs.

PERIODICALLY CHECK THIS RECEIVER HITCH TO ENSURE THAT ALL FASTENERS ARE TIGHT AND THAT ALL STRUCTURAL COMPONENTS ARE SOUND.

Keystone Automotive Operations Inc., warrants this product to be free of defects in material and/or workmanship at the time of retail purchase by the original purchaser. If the product is found to be defective, Keystone Automotive Operations Inc., may repair or replace the product, at their option, when the product is returned, prepaid, with proof of purchase. Alteration to, misuse of, or improper installation of this product voids the warranty. Keystone Automotive Operations Inc.'s liability is limited to repair or replacement of products found to be defective, and specifically excludes liability for incidental or consequential loss or damage. This product complies with safety specifications and requirements for connecting devices and towing systems of the state of New York, V.E.S.C. Regulation V-5 and SAE J684. For Technical & Warranty Support: 1-877-544-4449 Fax- 1-855-242-8922 www.huskytow.com

11202017