

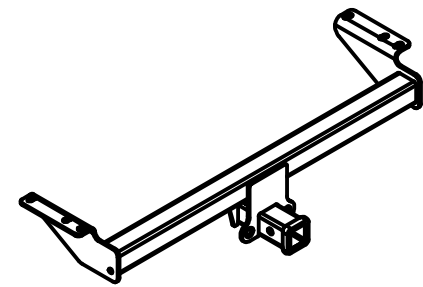

Class III Receiver Hitch

Part No. 69583C



Fits: VOLVO XC90



**GROSS LOAD CAPACITY WHEN USED AS A WEIGHT CARRYING HITCH: 3,500 LBS. TRAILER WEIGHT & 350 LBS. TONGUE WEIGHT.
GROSS LOAD CAPACITY WHEN USED AS A WEIGHT DISTRIBUTION HITCH: 5,000 LBS. TRAILER WEIGHT & 500 LBS. TONGUE WEIGHT**



WARNING: * DO NOT EXCEED VEHICLE MANUFACTURER'S RECOMMENDED TOWING CAPACITY. *****

Parts List			
ITEM	QTY	PART NUMBER	DESCRIPTION
1	2	1/2"	CONICAL TOOTHED WASHER
2	2	M12-1.75 x 40mm	HEX BOLT

RUBBER ISOLATOR REMOVAL DIAGRAM

This technique can be used if and Exhaust Hanger Removal Pliers is not available.

Using a 5/8" open end wrench, slide the wrench up to the rubber isolator, cradling the hanger rod as shown. Next place the flat edge of a pry bar between the wrench and the hanger stop or hanger rod. Then simply rotate the pry bar toward the wrench to remove the rubber isolator.

Note: Using a spray lubricant or soapy water on the hanger rod and the rubber isolator helps removal.

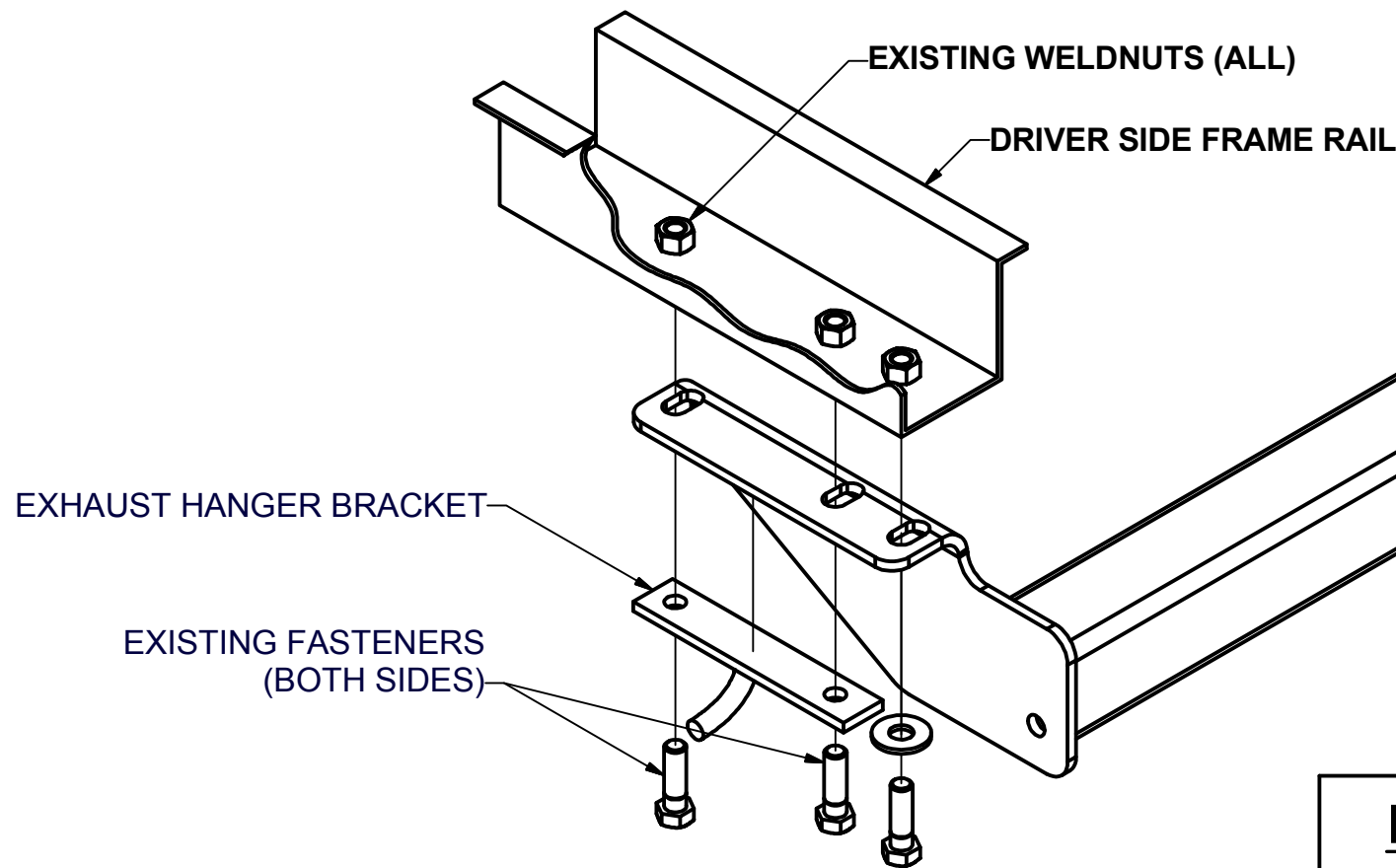
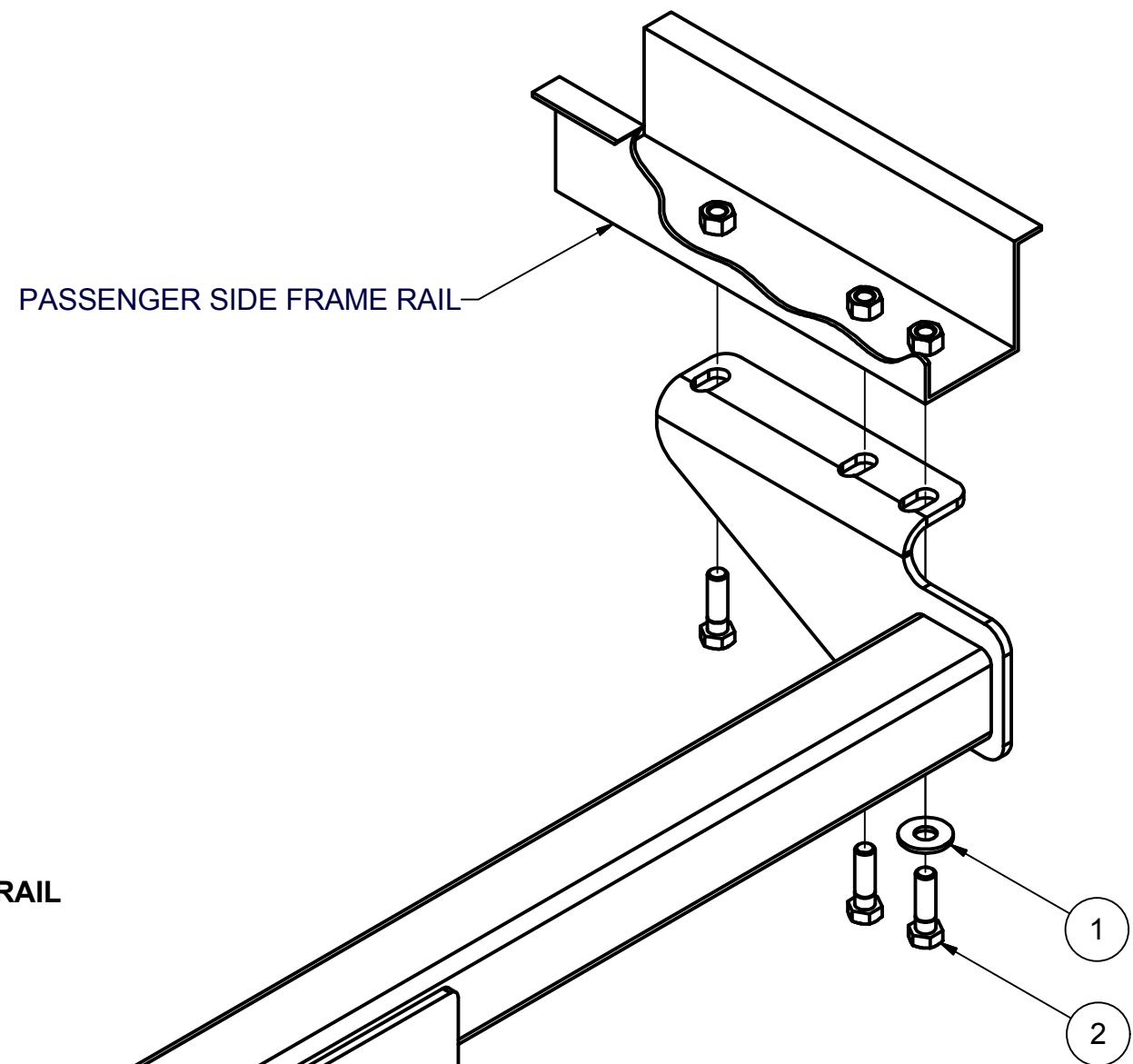

FRONT
↑
REAR

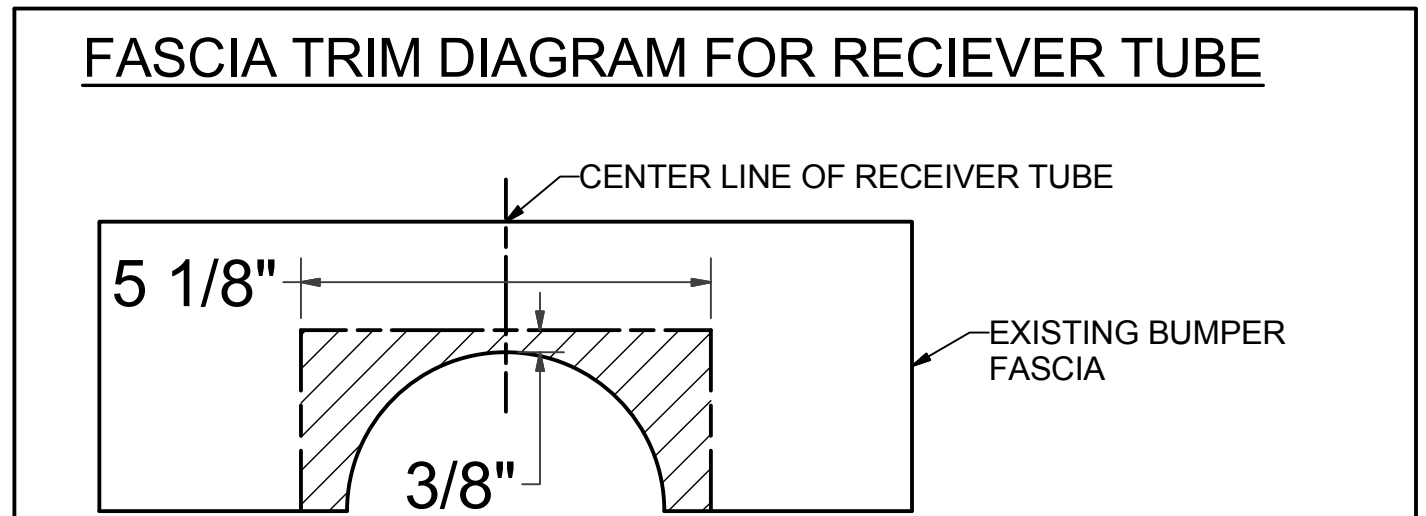

HITCH WEIGHT: 30 LBS.

INSTALL TIME

PROFESSIONAL: 30 MINUTES

NOVICE (DIY): 60 MINUTES

INSTALL NOTES:

- NO DRILLING REQUIRED
- FASCIA TRIMMING REQUIRED
- LOWER SPARE TIRE

INSTALLATION STEPS

1. Temporarily remove the existing M12 fasteners securing the tie down bracket to the passenger side frame rail and the rearmost exhaust hanger bracket from the driver's side frame rail. Retain the fasteners for later use.
2. Lower the spare tire to ease installation.
3. Loosely position the hitch under the car aligning the slots in the hitch with the three 12mm weld nuts in each frame rail.
4. Trim the fascia as shown to fit the hitch under the vehicle. (See above diagram.)
5. Replace the exhaust hanger bracket under the driver side plate of the hitch.
6. Mount the hitch using the 12mm bolts removed in Step 1 and the provided 12mm bolts and conical tooth washers as shown.
7. Torque all M12 fasteners to 79 lb.-ft.

PERIODICALLY CHECK THIS RECEIVER HITCH TO ENSURE THAT ALL FASTENERS ARE TIGHT AND THAT ALL STRUCTURAL COMPONENTS ARE SOUND.

Keystone Automotive Operations Inc., warrants this product to be free of defects in material and/or workmanship at the time of retail purchase by the original purchaser. If the product is found to be defective, Keystone Automotive Operations Inc., may repair or replace the product, at their option, when the product is returned, prepaid, with proof of purchase. Alteration to, misuse of, or improper installation of this product voids the warranty. Keystone Automotive Operations Inc.'s liability is limited to repair or replacement of products found to be defective, and specifically excludes liability for incidental or consequential loss or damage. This product complies with safety specifications and requirements for connecting devices and towing systems of the state of New York, V.E.S.C. Regulation V-5 and SAE J684. For Technical & Warranty Support: 1-877-544-4449 Fax- 1-855-242-8922 www.huskytow.com **11202017**