

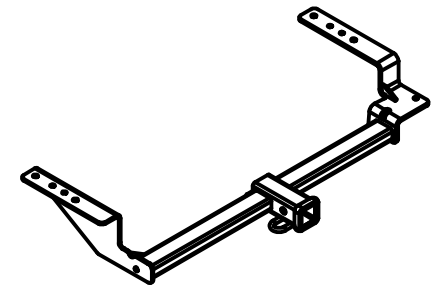

# Class III Receiver Hitch Part No. 69581C



**Fits: 2002-2006 HONDA CRV** (WILL NOT FIT HYBRID)



GROSS LOAD CAPACITY WHEN USED AS A WEIGHT CARRYING HITCH: 3500 LBS. TRAILER WEIGHT & 350 LBS. TONGUE WEIGHT.  
**WARNING: \*\*\* DO NOT EXCEED VEHICLE MANUFACTURER'S RECOMMENDED TOWING CAPACITY. \*\*\***



Parts List			
ITEM	QTY	PART NUMBER	DESCRIPTION
1	2	CM-438-FW	7/16" FISHWIRE TOOL
2	2	HFN3816	HEX FLANGE NUT
3	4	7/16-14 x 1 1/4	CARRIAGE BOLT
4	4	CM-SP2	.250 x .88 x 2.25" SQUARE HOLE SPACER
5	4	7/16-14	LARGE HEX FLANGE NUT
6	1	CM-3805-UBR	3/8-16 x 1.938 x .875" U-BOLT

### RUBBER ISOLATOR REMOVAL DIAGRAM

This technique can be used if and Exhaust Hanger Removal Pliers is not available.

Using a 5/8" open end wrench, slide the wrench up to the rubber isolator, cradling the hanger rod as shown. Next place the flat edge of a pry bar between the wrench and the hanger stop or hanger rod. Then simply rotate the pry bar toward the wrench to remove the rubber isolator.

Note: Using a spray lubricant or soapy water on the hanger rod and the rubber isolator helps removal.

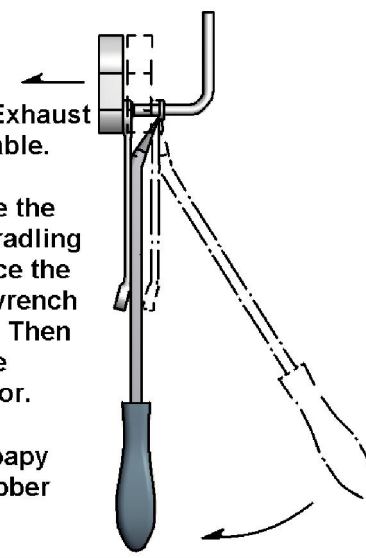

### FISHWIRE TECHNIQUE

INSERT COILED END OF FISHWIRE TOOL THROUGH HITCH MOUNTING HOLE IN VEHICLE FRAME RAIL AND OUT THE ACCESS HOLE. PASS COILED END OF FISHWIRE THROUGH SPACER AND THREAD BOLT INTO COIL. KINK WIRE TO KEEP SPACER SEPERATE FROM BOLT AS SHOWN. PULL FISHWIRE, SPACER, AND BOLT THROUGH FRAME AND OUT MOUNTING HOLE. USE FISHWIRE TO GUIDE HITCH DURING MOUNTING AND PREVENT LOSS OF BOLT / SPACER INSIDE FRAME RAIL.

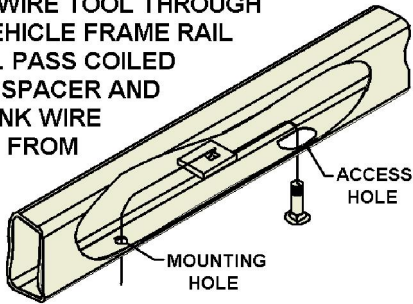

\*\*NOTE: SOME VEHICLES MAY FISHWIRE THROUGH END OF FRAME\*\*

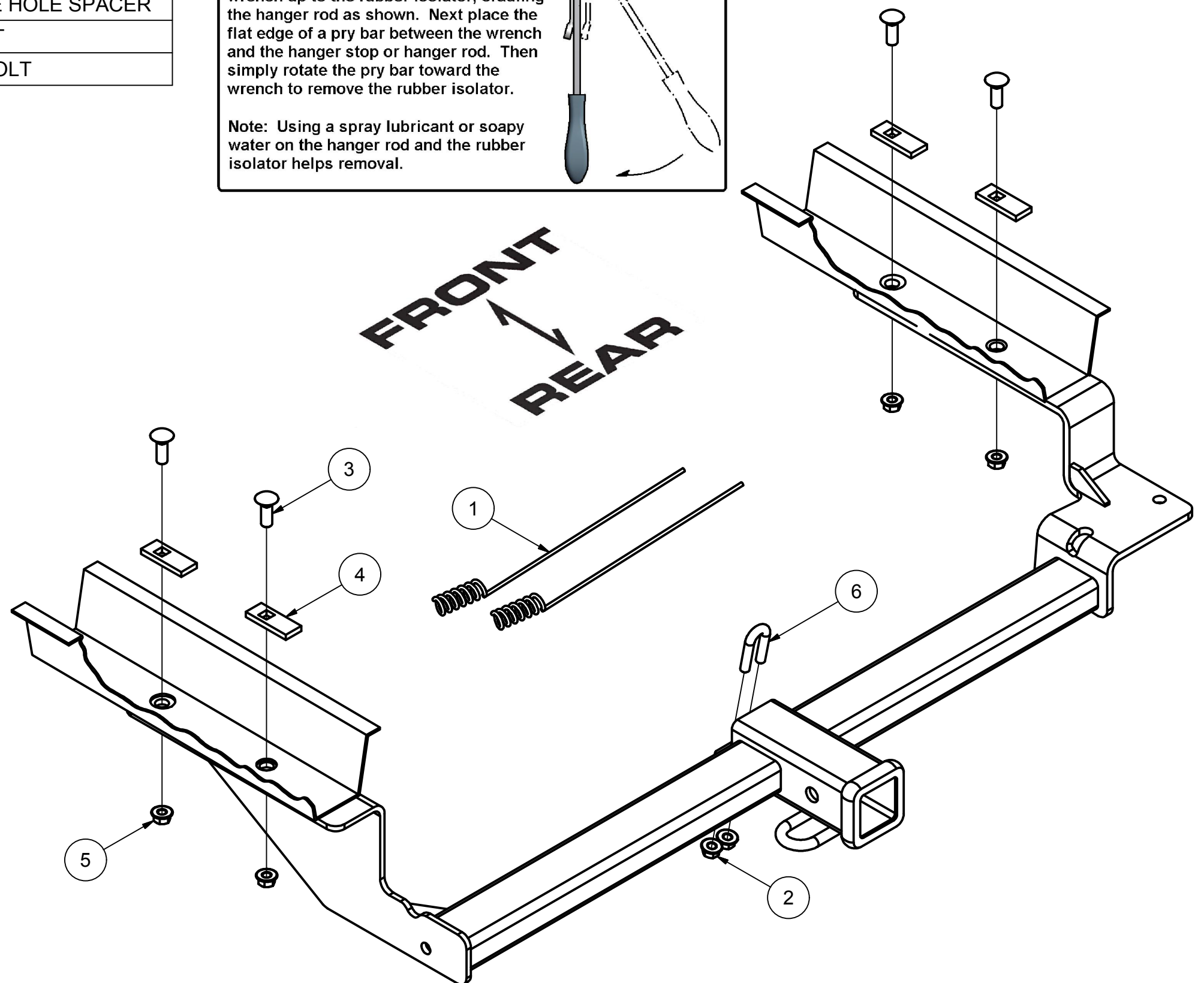

HITCH WEIGHT: 32 LBS.

#### INSTALL TIME

PROFESSIONAL: 30 MINUTES

NOVICE (DIY): 65 MINUTES

#### INSTALL NOTES:

- NO DRILLING REQUIRED
- FISHWIRING REQUIRED
- TEMPORARILY LOWER EXHAUST

## INSTALLATION STEPS

1. Lower the exhaust by removing the two rear exhaust hangers and one in front of the axle.
2. After the exhaust has been lowered, fishwire a 7/16" carriage bolt and spacer through the large frame hole and out the small front hole in the frame.
3. Remove the fishwire from the front bolt and fishwire a carriage bolt and spacer into the rear frame hole. Repeat the process for the drivers side frame rail.
4. Place the U-bolt over the tow hook in the middle of the vehicle.
5. After all hardware has been properly installed raise the hitch into position and secure with U-bolt and flange nuts first, then attach the remaining 7/16" hardware.
6. Torque all 7/16" hardware to 70 ft-lbs and all 3/8" hardware to 45 ft-lbs.
7. Reattach the three exhaust hangers removed in Step 1.

**NOTE: Modify exhaust hangers if muffler interferes with hitch.**

**PERIODICALLY CHECK THIS RECEIVER HITCH TO ENSURE THAT ALL FASTENERS ARE TIGHT AND THAT ALL STRUCTURAL COMPONENTS ARE SOUND.**

Keystone Automotive Operations Inc., warrants this product to be free of defects in material and/or workmanship at the time of retail purchase by the original purchaser. If the product is found to be defective, Keystone Automotive Operations Inc., may repair or replace the product, at their option, when the product is returned, prepaid, with proof of purchase. Alteration to, misuse of, or improper installation of this product voids the warranty. Keystone Automotive Operations Inc.'s liability is limited to repair or replacement of products found to be defective, and specifically excludes liability for incidental or consequential loss or damage. This product complies with safety specifications and requirements for connecting devices and towing systems of the state of New York, V.E.S.C. Regulation V-5 and SAE J684. For Technical & Warranty Support: 1-877-544-4449 Fax- 1-855-242-8922 [www.huskytow.com](http://www.huskytow.com)

11202017