

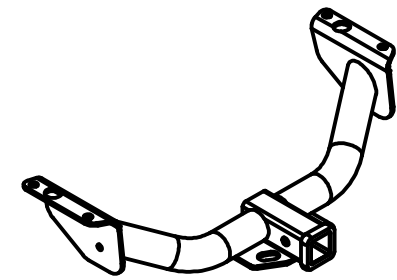

# Class III Receiver Hitch

## Part No. 69563C



**Fits: FORD RANGER & MAZDA B2300, B3000, B4000**



GROSS LOAD CAPACITY WHEN USED AS A WEIGHT CARRYING HITCH: 4,000 LBS. TRAILER WEIGHT & 400 LBS. TONGUE WEIGHT.  
GROSS LOAD CAPACITY WHEN USED AS A WEIGHT DISTRIBUTION HITCH: 6,000 LBS. TRAILER WEIGHT & 600 LBS. TONGUE WEIGHT



**WARNING: \*\*\* DO NOT EXCEED VEHICLE MANUFACTURER'S RECOMMENDED TOWING CAPACITY. \*\*\***

Parts List			
ITEM	QTY	PART NUMBER	DESCRIPTION
1	4	1/2-13 x 1 3/4	CARRIAGE BOLT
2	4	HFN 1213	HEX FLANGE NUT
3	6	CM-SP1	.250 x 1.50 x 2.00" SQUARE HOLE SPACER

**NOTE: 97 AND PRIOR YEARS**  
**19mm OPEN END STYLE**  
**WRENCH MUST BE PURCHASED**  
**TO ALLOW REMOVAL OF SPARE**  
**TIRE AFTER HITCH INSTALLATION**

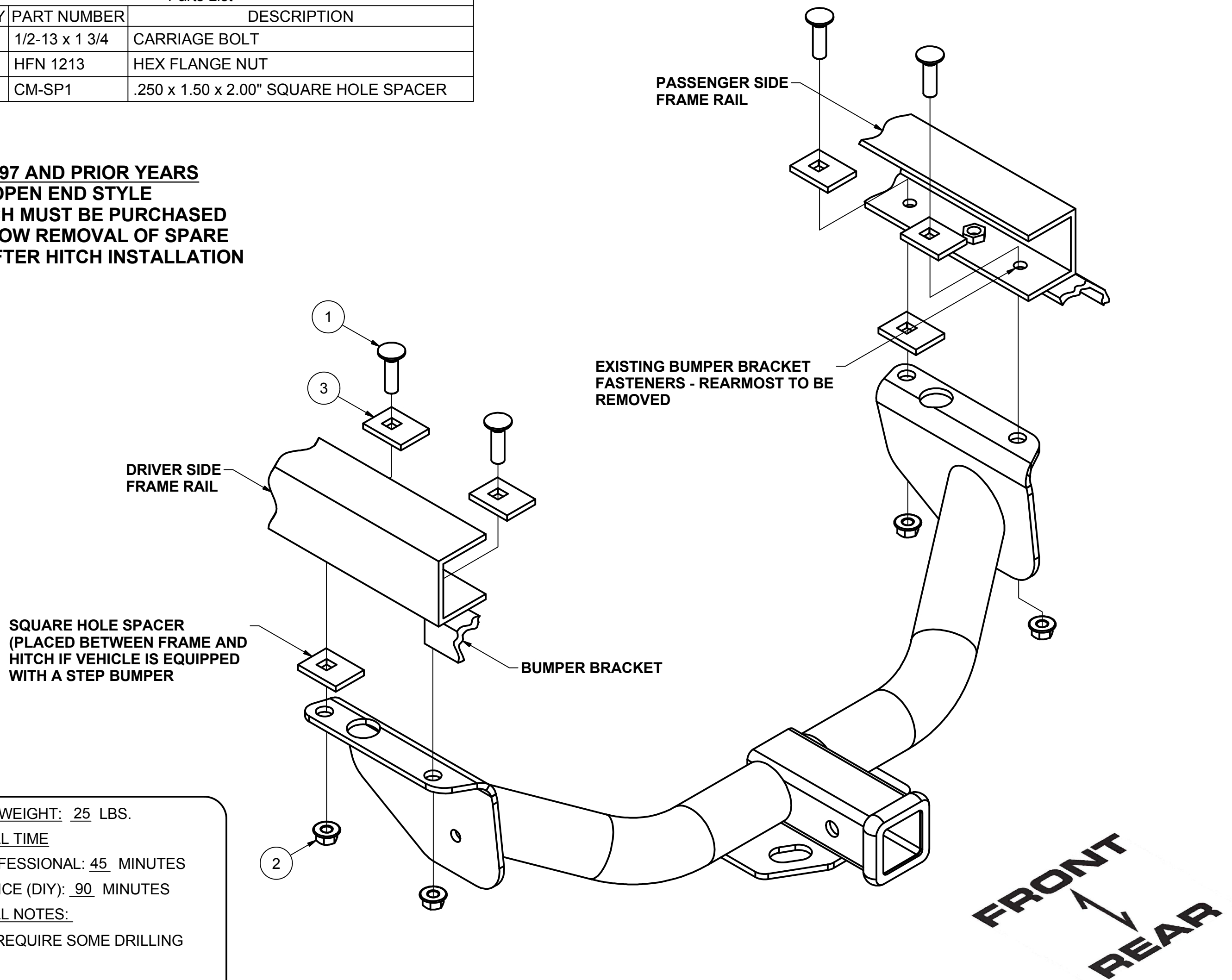

**HITCH WEIGHT:** 25 LBS.

**INSTALL TIME**

PROFESSIONAL: 45 MINUTES

NOVICE (DIY): 90 MINUTES

**INSTALL NOTES:**

-MAY REQUIRE SOME DRILLING

### INSTALLATION STEPS

**NOTE: Relocation of tire bracket is not required.**

- 1) **For vehicles with step bumper**, remove rearmost bumper bracket bolts and J-nuts (both sides).
- 2) **Position hitch on vehicle**, sandwiching the bumper brackets (if present) between the hitch and the vehicle frame. Install rearmost fasteners as shown.
- 3) **Using hitch as a template**, drill two 1/2" holes into frame at forward end of hitch.  
Note: On some models, these holes may already exist.
- 4) **Install remaining fasteners** as shown. For vehicles with step bumper, place square hole spacer between frame and side brackets at forward attachment.
- 5) **Torque** all 1/2" fasteners to 110 lb-ft.

**PERIODICALLY CHECK THIS RECEIVER HITCH TO ENSURE THAT ALL FASTENERS ARE TIGHT AND THAT ALL STRUCTURAL COMPONENTS ARE SOUND.**

Keystone Automotive Operations Inc., warrants this product to be free of defects in material and/or workmanship at the time of retail purchase by the original purchaser. If the product is found to be defective, Keystone Automotive Operations Inc., may repair or replace the product, at their option, when the product is returned, prepaid, with proof of purchase. Alteration to, misuse of, or improper installation of this product voids the warranty. Keystone Automotive Operations Inc.'s liability is limited to repair or replacement of products found to be defective, and specifically excludes liability for incidental or consequential loss or damage. This product complies with safety specifications and requirements for connecting devices and towing systems of the state of New York, V.E.S.C. Regulation V-5 and SAE J684. For Technical & Warranty Support: 1-877-544-4449 Fax- 1-855-242-8922 [www.huskytow.com](http://www.huskytow.com)

11202017