

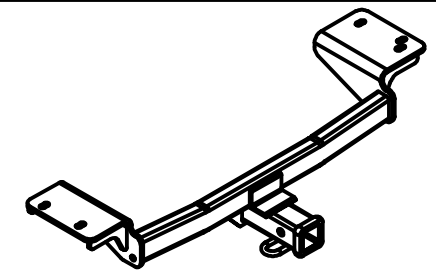

Class III Receiver Hitch

Part No. 69561C



Fits: KIA SPORTAGE / HYUNDAI TUCSON



GROSS LOAD CAPACITY WHEN USED AS A WEIGHT CARRYING HITCH: 3500 LBS. TRAILER WEIGHT & 525 LBS. TONGUE WEIGHT.
GROSS LOAD CAPACITY WHEN USED AS A WEIGHT DISTRIBUTION HITCH: 5250 LBS. TRAILER WEIGHT & 525 LBS. TONGUE WEIGHT

WARNING: * DO NOT EXCEED VEHICLE MANUFACTURER'S RECOMMENDED TOWING CAPACITY. *****



Parts List			
ITEM	QTY	PART NUMBER	DESCRIPTION
1	4	M10 - 1.25 x 30	HEX BOLT
2	4	3/8"	CONICAL TOOTHED WASHER

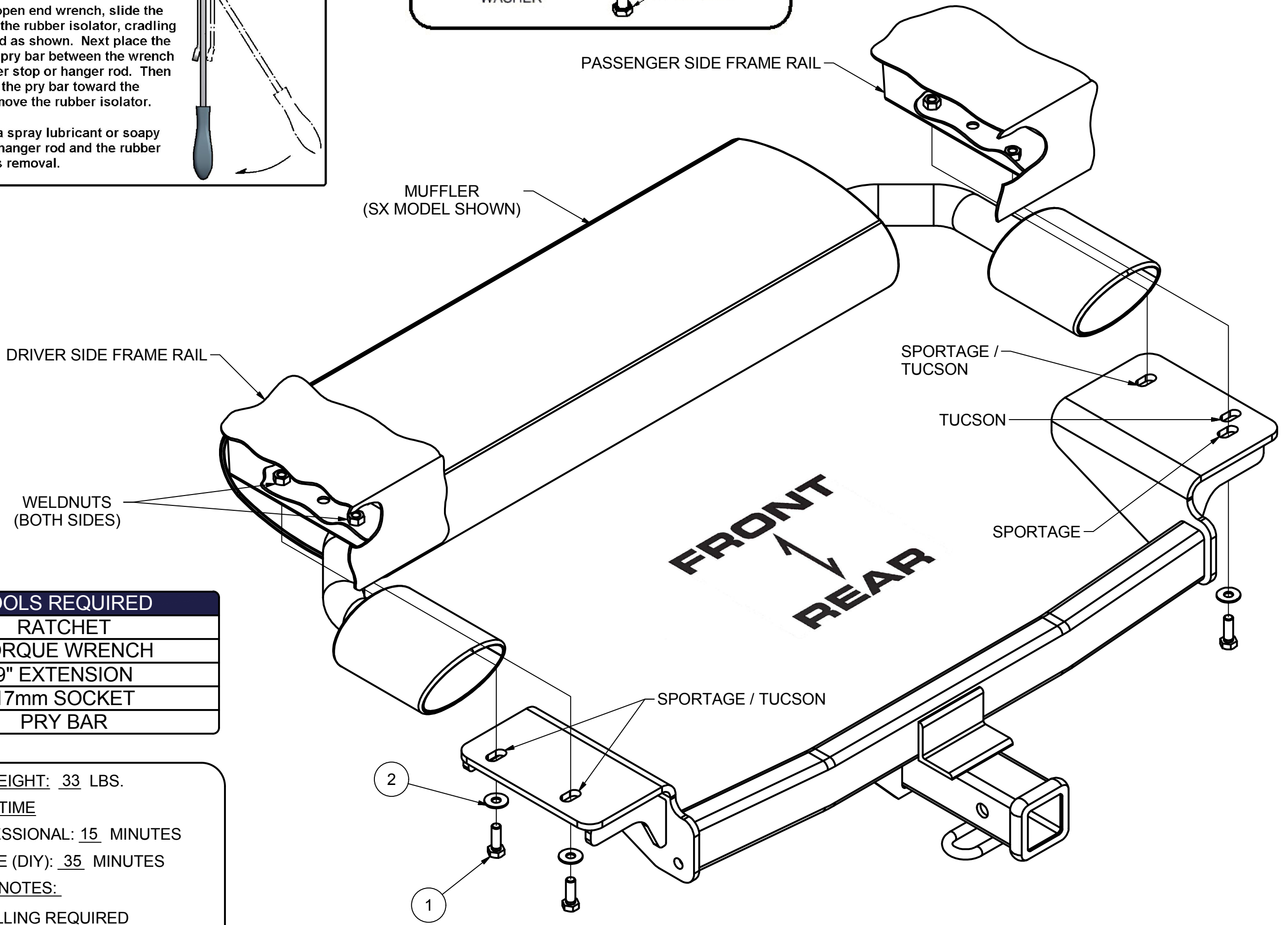
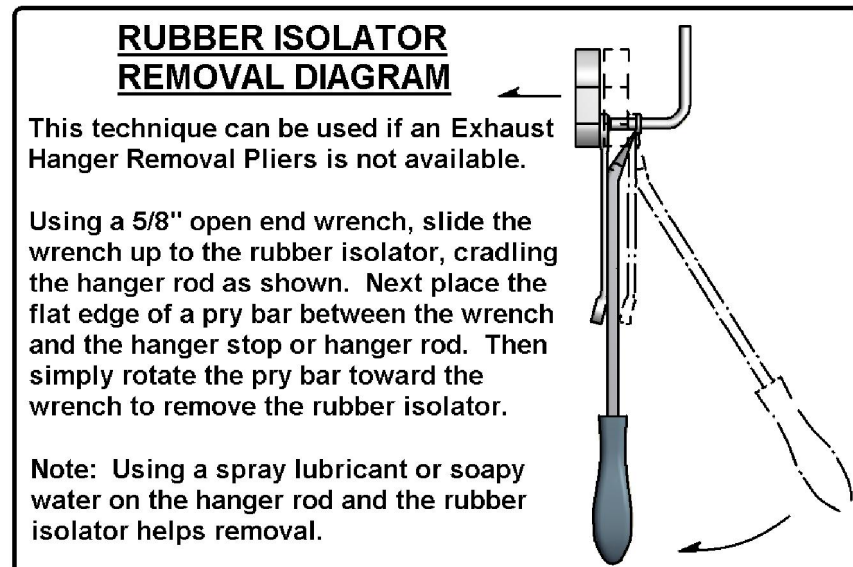
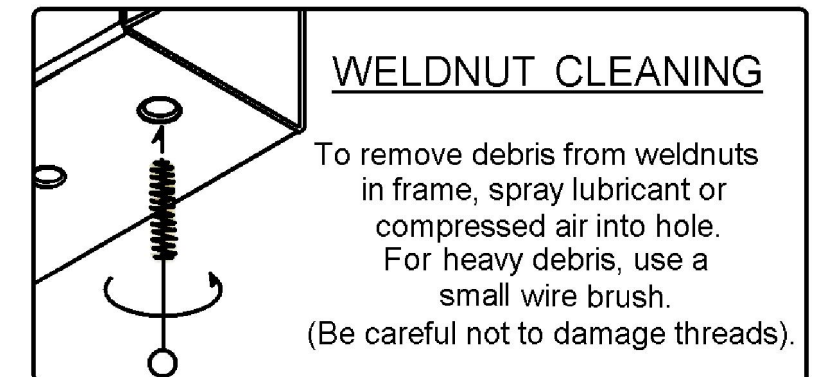
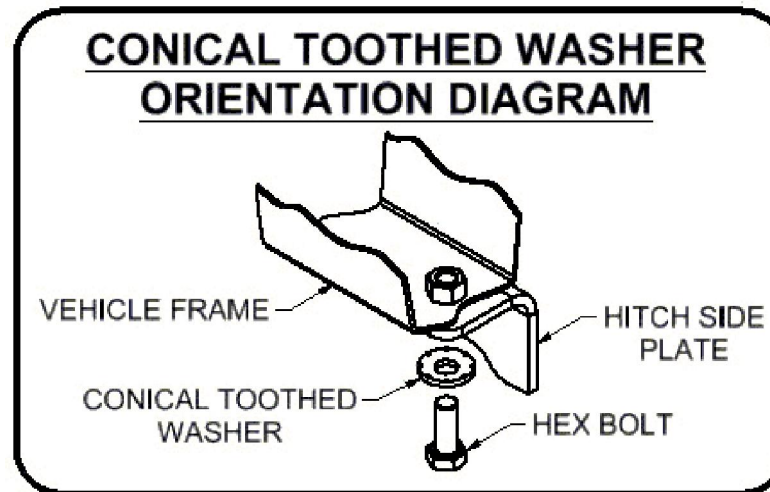

TOOLS REQUIRED
RATCHET
TORQUE WRENCH
9" EXTENSION
17mm SOCKET
PRY BAR

HITCH WEIGHT: 33 LBS.
INSTALL TIME
PROFESSIONAL: 15 MINUTES
NOVICE (DIY): 35 MINUTES
INSTALL NOTES:
-NO DRILLING REQUIRED
-LOWER EXHAUST

INSTALLATION STEPS

1. Locate weldnuts in frame rails (See Weldnut Cleaning Diagram).
2. Lower exhaust by removing (2) rubber isolators, support exhaust as needed to prevent damaging (See Rubber Isolator Removal Diagram).
3. Raise hitch into position, aligning holes in side plates with weldnuts in the frame and secure using M10-1.25 x 30mm hex bolts and 3/8" conical toothed washers.
Note: It may be necessary to cut or bend rearward lip of heat shield in order to raise hitch into position.
4. Torque all M10 fasteners to 48 ft-lbs.
5. Raise exhaust back into position.

PERIODICALLY CHECK THIS RECEIVER HITCH TO ENSURE THAT ALL FASTENERS ARE TIGHT AND THAT ALL STRUCTURAL COMPONENTS ARE SOUND.

Keystone Automotive Operations Inc., warrants this product to be free of defects in material and/or workmanship at the time of retail purchase by the original purchaser. If the product is found to be defective, Keystone Automotive Operations Inc., may repair or replace the product, at their option, when the product is returned, prepaid, with proof of purchase. Alteration to, misuse of, or improper installation of this product voids the warranty. Keystone Automotive Operations Inc.'s liability is limited to repair or replacement of products found to be defective, and specifically excludes liability for incidental or consequential loss or damage. This product complies with safety specifications and requirements for connecting devices and towing systems of the state of New York, V.E.S.C. Regulation V-5 and SAE J684. For Technical & Warranty Support: 1-877-544-4449 Fax- 1-855-242-8922 www.huskytow.com

11202017