

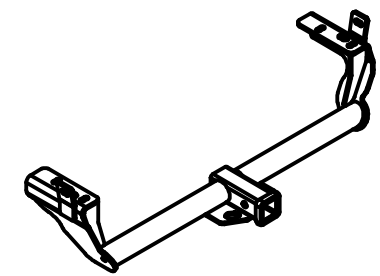

Class III Receiver Hitch

Part No. 69550C



Fits: FORD EDGE



GROSS LOAD CAPACITY WHEN USED AS A WEIGHT CARRYING HITCH: 4,000 LBS. TRAILER WEIGHT & 600 LBS. TONGUE WEIGHT.
WARNING: * DO NOT EXCEED VEHICLE MANUFACTURER'S RECOMMENDED TOWING CAPACITY. *****



Parts List			
ITEM	QTY	PART NUMBER	DESCRIPTION
1	6	1/2-13 x 1 1/2, GR8	CARRIAGE BOLT
2	6	CM-SP4	.250 x 1.50 x 3.00" SQUARE HOLE SPACER
3	6	HFN 1213, GR8	HEX FLANGE NUT
4	4	1_2 FISHWIRE	1/2" FISHWIRE

FISHWIRE TECHNIQUE

INSERT COILED END OF FISHWIRE TOOL THROUGH HITCH MOUNTING HOLE IN VEHICLE FRAME RAIL AND OUT THE ACCESS HOLE. PASS COILED END OF FISHWIRE THROUGH SPACER AND THREAD BOLT INTO COIL. KINK WIRE TO KEEP SPACER SEPERATE FROM BOLT AS SHOWN. PULL FISHWIRE, SPACER, AND BOLT THROUGH FRAME AND OUT MOUNTING HOLE. USE FISHWIRE TO GUIDE HITCH DURING MOUNTING AND PREVENT LOSS OF BOLT / SPACER INSIDE FRAME RAIL.

NOTE: SOME VEHICLES MAY FISHWIRE THROUGH END OF FRAME

RUBBER ISOLATOR REMOVAL DIAGRAM

This technique can be used if an Exhaust Hanger Removal Pliers is not available.

Using a 5/8" open end wrench, slide the wrench up to the rubber isolator, cradling the hanger rod as shown. Next place the flat edge of a pry bar between the wrench and the hanger stop or hanger rod. Then simply rotate the pry bar toward the wrench to remove the rubber isolator.

Note: Using a spray lubricant or soapy water on the hanger rod and the rubber isolator helps removal.

TOOLS REQUIRED

7/32" SOCKET
3/4" SOCKET
5.5mm SOCKET (SPORT MODEL)
10mm SOCKET
T20 TORX BIT
RATCHET
TORQUE WRENCH
AVIATION SHEARS
SAFETY GLASSES

HITCH WEIGHT: 38 LBS.
 INSTALL TIME
 PROFESSIONAL: 30 MINUTES
 NOVICE (DIY): 60 MINUTES

INSTALL NOTES:
 - TRIM UNDERBODY PANELS
 - FISHWIRING REQUIRED
 - LOWER EXHAUST (REMOVE BEZELS)
 - NO DRILLING REQUIRED

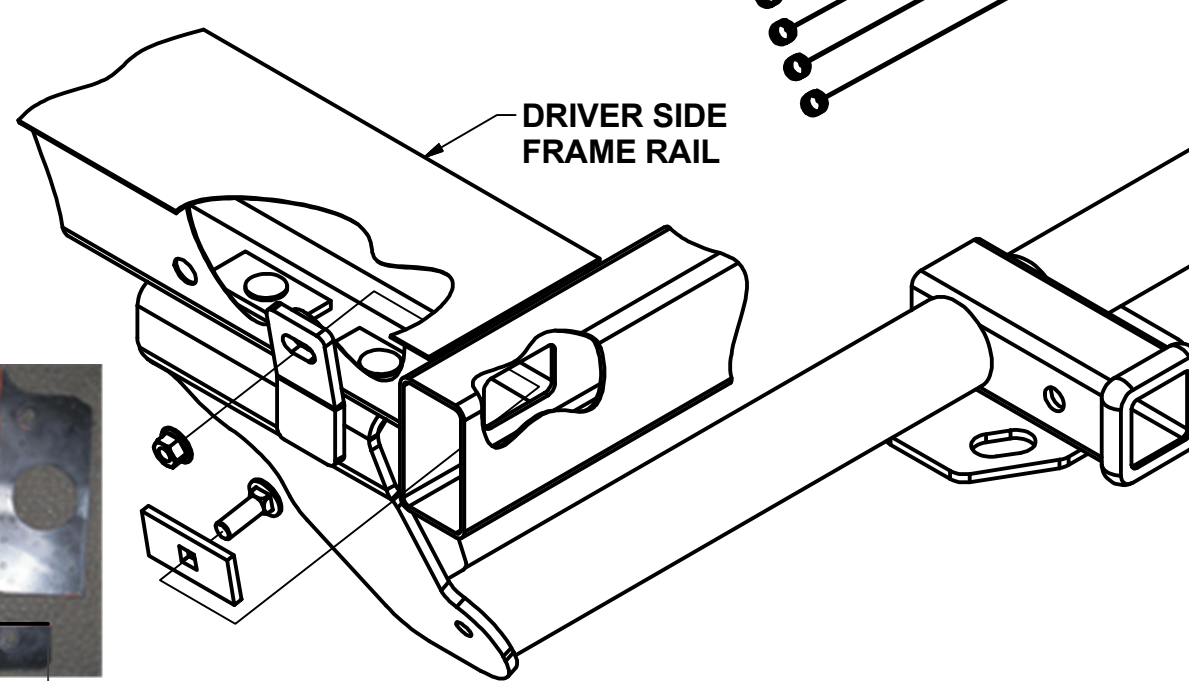
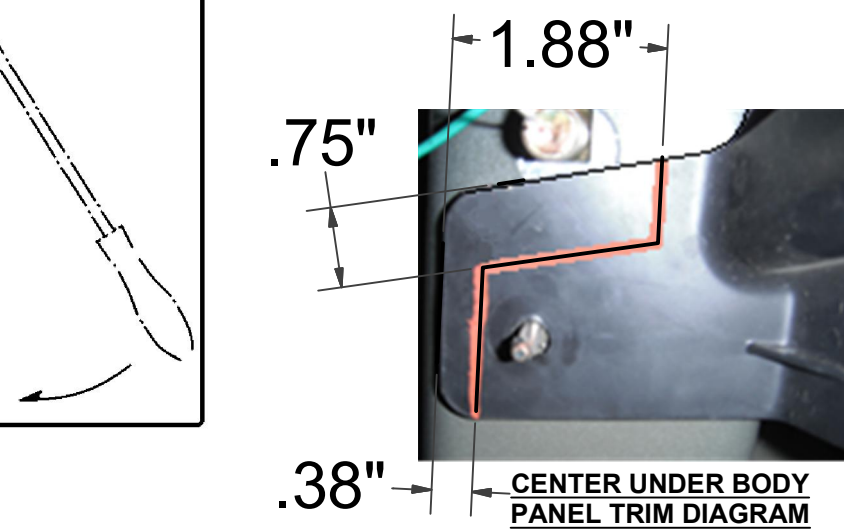

INSTALLATION STEPS

- Support and lower the exhaust by removing (2) rubber isolators mounted to the muffler. **Note: Sport model will require the removal of the exhaust bezels using a 5.5mm socket and a T20 Torx bit.** Remove the panels from behind the rear wheels by removing (2) hex nuts using a 10mm socket and (2) screws with a 7/32" socket. Set panels aside for later installation.
- Fishwire (3) CM-SP4 spacers and (3) 1/2" carriage bolts into the mounting holes as shown for both frames.
- Trim the center under body panel outer tabs to allow easier mounting of the hitch. Trim the removed underbody side panels as shown in the diagram above to allow for reinstallation.
- Raise hitch over exhaust and thread fishwires into the mounting holes. Raise hitch into mounting position, remove the fishwires and install (6) supplied 1/2" hex flange nuts.

Note: The hitch side plates will be located between the center underbody panel tabs and the frame rails.

5) Torque all 1/2" fasteners to 110 lb-ft. Reinstall the trimmed underbody panels onto the vehicle using the hardware removed in step 1. Note: The washer/nut may require trimming of the washer for reinstallation.

6) Raise the exhaust back into position and reinstall rubber isolators and exhaust bezels if removed.

Note: On vehicles equipped with hands free lift gate, perform the kick motion on the left or right side of the receiver tube.

PERIODICALLY CHECK THIS RECEIVER HITCH TO ENSURE THAT ALL FASTENERS ARE TIGHT AND THAT ALL STRUCTURAL COMPONENTS ARE SOUND.