

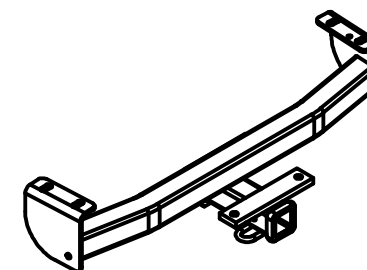

# Class III Receiver Hitch Part No. 69545C



**Fits: TOYOTA TACOMA**



**GROSS LOAD CAPACITY WHEN USED AS A WEIGHT CARRYING HITCH: 6000 LBS. TRAILER WEIGHT & 900 LBS. TONGUE WEIGHT.  
GROSS LOAD CAPACITY WHEN USED AS A WEIGHT DISTRIBUTION HITCH: 8000 LBS. TRAILER WEIGHT & 900 LBS. TONGUE WEIGHT**



**WARNING: \*\*\* DO NOT EXCEED VEHICLE MANUFACTURER'S RECOMMENDED TOWING CAPACITY. \*\*\***

Parts List					
ITEM	QTY	PART NUMBER	DESCRIPTION		
1	2	1_2 x 30 FISHWIRE	1/2" x 30" FISHWIRE		
2	4	M12 - 1.25 x 40 HEX	HEX BOLT		
3	4	1/2"	CONICAL TOOTHED WASHER		
4	2	HFN 1213	HEX FLANGE NUT		
5	2	1/2-13 x 1 3/4	CARRIAGE BOLT		
6	2	CM-SP19	.250 x 1.25 x 3.00" SQUARE HOLE SPACER		

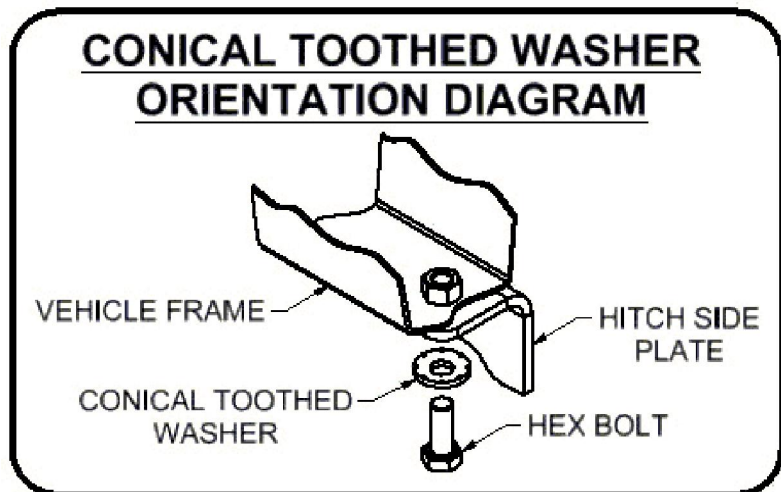
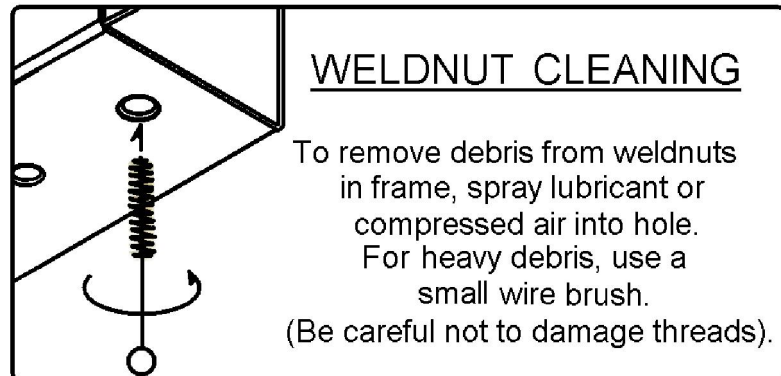

TOOLS REQUIRED
RATCHET
TORQUE WRENCH
19mm SOCKET
3/4" SOCKET
10" SOCKET EXTENSION

BUMPER MOUNT PLATE (BOTH SIDES)

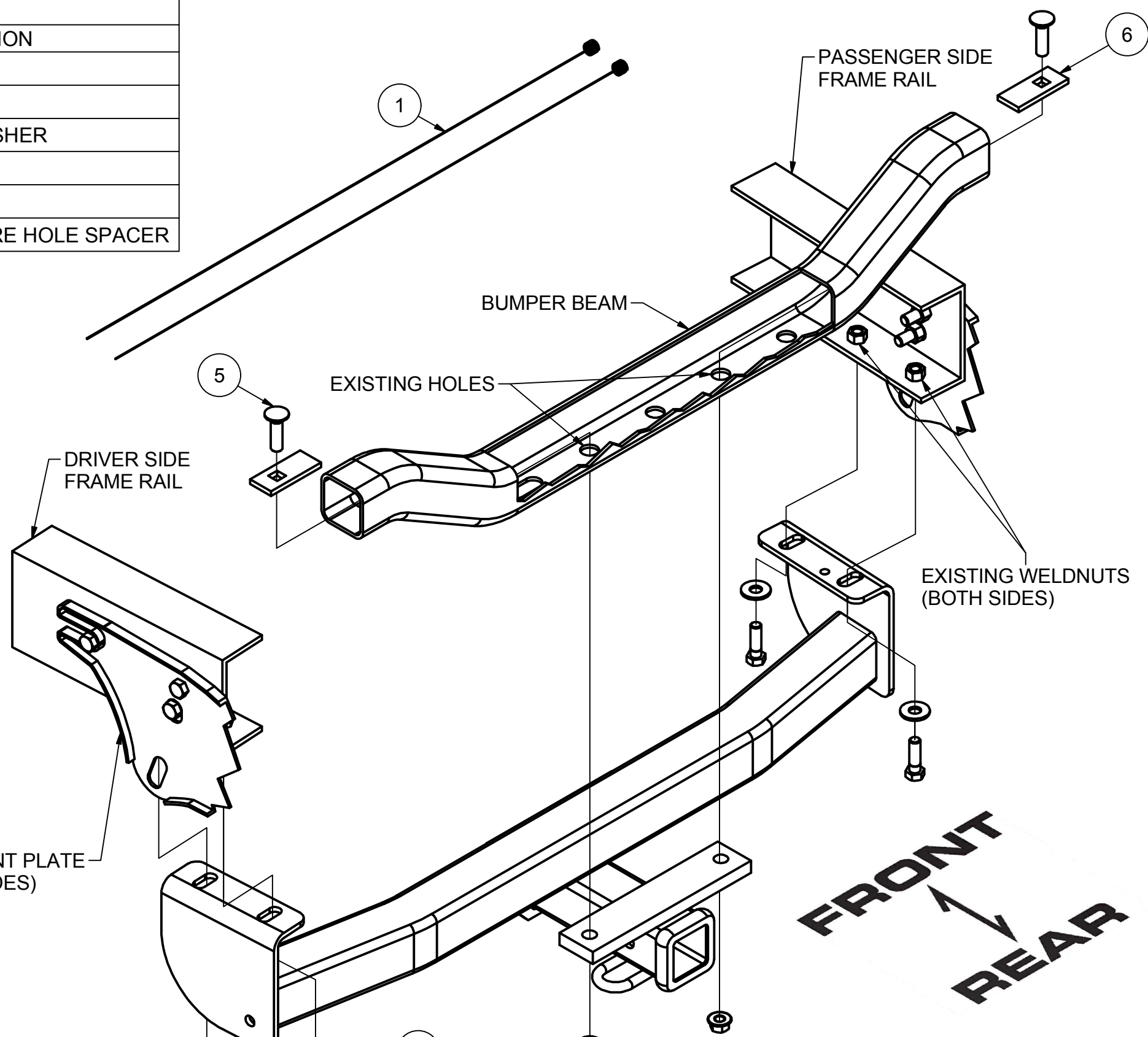

3. ROTATE BOLT AND SPACER THROUGH MOUNTING HOLE

BUMPER BEAM

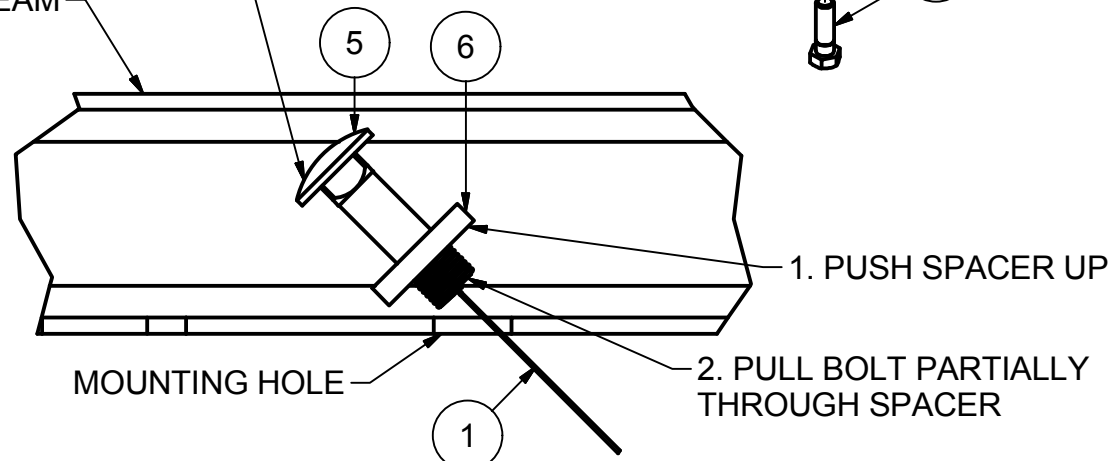

**BUMPER BEAM FISHWIRE DIAGRAM**

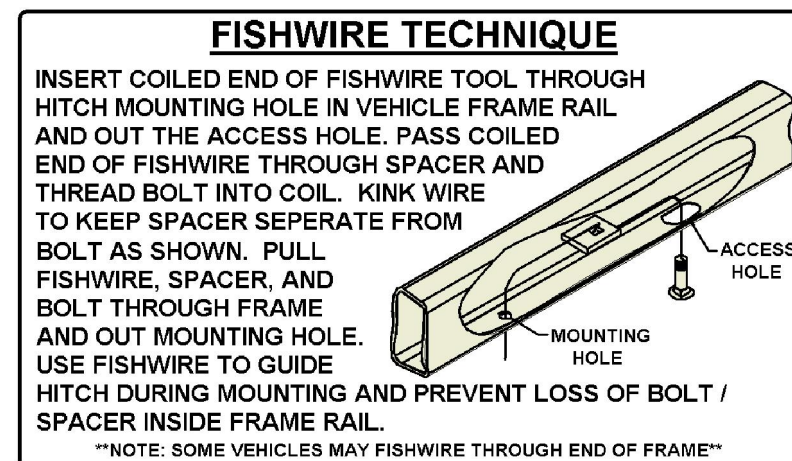

HITCH WEIGHT: 34 LBS.

INSTALL TIME

PROFESSIONAL: 20 MINUTES

NOVICE (DIY): 40 MINUTES

INSTALL NOTES:

- NO DRILLING REQUIRED
- FISHWIRE HARDWARE
- CLEAN WELDNUTS

## INSTALLATION STEPS

1. Fishwire (2) 1/2" carriage bolts and (2) CM-SP19 spacers through ends of bumper beam and out mounting holes as shown. (See BUMPER BEAM FISHWIRE DIAGRAM)
2. Raise hitch into position between bumper mount plates and align slots in hitch with existing vehicle weldnuts in the frame rails.  
Install (4) M12-1.25 hex bolts and (4) 1/2" conical toothed washers into existing weldnuts, as shown.
3. Install (2) 1/2"-13 hex flange nuts on to carriage bolts.
4. Torque M12 fasteners to 86 lb-ft and 1/2" fasteners to 110 lb-ft.

**PERIODICALLY CHECK THIS RECEIVER HITCH TO ENSURE THAT ALL FASTENERS ARE TIGHT AND THAT ALL STRUCTURAL COMPONENTS ARE SOUND.**

Keystone Automotive Operations Inc., warrants this product to be free of defects in material and/or workmanship at the time of retail purchase by the original purchaser. If the product is found to be defective, Keystone Automotive Operations Inc., may repair or replace the product, at their option, when the product is returned, prepaid, with proof of purchase. Alteration to, misuse of, or improper installation of this product voids the warranty. Keystone Automotive Operations Inc.'s liability is limited to repair or replacement of products found to be defective, and specifically excludes liability for incidental or consequential loss or damage. This product complies with safety specifications and requirements for connecting devices and towing systems of the state of New York, V.E.S.C. Regulation V-5 and SAE J684. For Technical & Warranty Support: 1-877-544-4449 Fax- 1-855-242-8922 [www.huskytow.com](http://www.huskytow.com)

11202017