

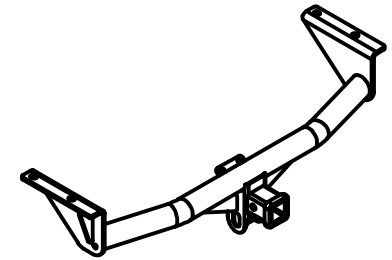

Class III Receiver Hitch

Part No. 69531C



Fits: CHEVROLET COLORADO & GMC CANYON



GROSS LOAD CAPACITY WHEN USED AS A WEIGHT CARRYING HITCH: 6,000 LBS. TRAILER WEIGHT & 900 LBS. TONGUE WEIGHT.
GROSS LOAD CAPACITY WHEN USED AS A WEIGHT DISTRIBUTION HITCH: 8,000 LBS. TRAILER WEIGHT & 900 LBS. TONGUE WEIGHT

WARNING: * DO NOT EXCEED VEHICLE MANUFACTURER'S RECOMMENDED TOWING CAPACITY. *****



NOTE: REUSE FACTORY MOUNTING HARDWARE AND MOVE CLIP NUTS TO SPARE TIRE SUPPORT BRACKET

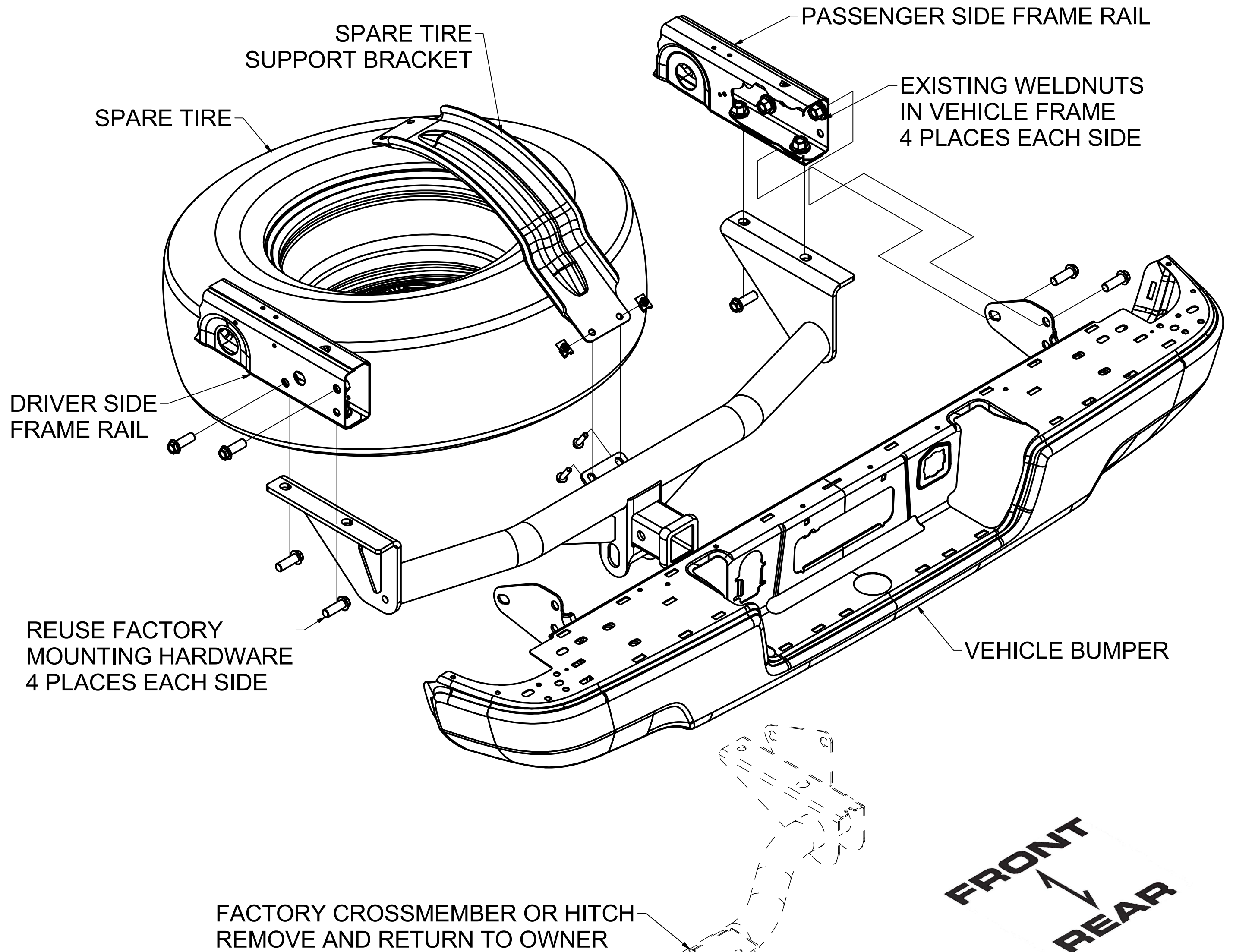

HITCH WEIGHT: 38 LBS.

INSTALL TIME

PROFESSIONAL: 60 MINUTES

NOVICE (DIY): 60 MINUTES

INSTALL NOTES:

- LOWER SPARE TIRE
- REMOVE FACTORY COMPONENTS
- WELDNUT CLEANING
- NO DRILLING REQUIRED

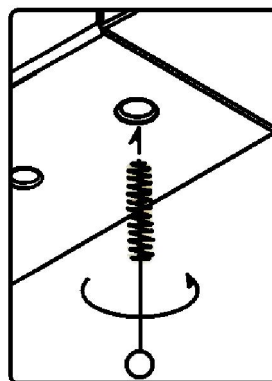

WELDNUT CLEANING

To remove debris from weldnuts in frame, spray lubricant or compressed air into hole. For heavy debris, use a small wire brush. (Be careful not to damage threads).

TOOLS REQUIRED

RATCHET
13mm SOCKET
21mm SOCKET
9" EXTENSION
JACK STANDS
SPRAY LUBRICANT
WIRE PIPE BRUSH
TORQUE WRENCH

PERIODICALLY CHECK THIS RECEIVER HITCH TO ENSURE THAT ALL FASTENERS ARE TIGHT AND THAT ALL STRUCTURAL COMPONENTS ARE SOUND.

Keystone Automotive Operations Inc., warrants this product to be free of defects in material and/or workmanship at the time of retail purchase by the original purchaser. If the product is found to be defective, Keystone Automotive Operations Inc., may repair or replace the product, at their option, when the product is returned, prepaid, with proof of purchase. Alteration to, misuse of, or improper installation of this product voids the warranty. Keystone Automotive Operations Inc.'s liability is limited to repair or replacement of products found to be defective, and specifically excludes liability for incidental or consequential loss or damage. This product complies with safety specifications and requirements for connecting devices and towing systems of the state of New York, V.E.S.C. Regulation V-5 and SAE J684. For Technical & Warranty Support: 1-877-544-4449 Fax- 1-855-242-8922 www.huskytow.com

11202017



Class III Receiver Hitch Part No. 69531C

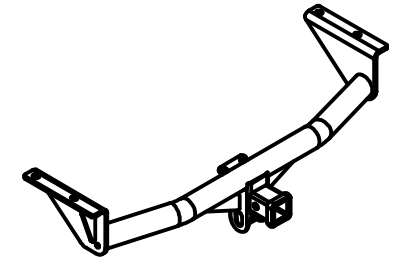

Fits: **CHEVROLET COLORADO & GMC CANYON**



GROSS LOAD CAPACITY WHEN USED AS A WEIGHT CARRYING HITCH: 6,000 LBS. TRAILER WEIGHT & 900 LBS. TONGUE WEIGHT.
GROSS LOAD CAPACITY WHEN USED AS A WEIGHT DISTRIBUTION HITCH: 8,000 LBS. TRAILER WEIGHT & 900 LBS. TONGUE WEIGHT

WARNING: * DO NOT EXCEED VEHICLE MANUFACTURER'S RECOMMENDED TOWING CAPACITY. *****



INSTALLATION STEPS

- 1.) Lower spare tire using the vehicle service tools located in the cab of the truck. Loosen the spare tire support bracket by removing (2) bolts with a 13mm socket by the spare winch. Remove the 2 bolts from the factory hitch or cross member and transfer the (2) clip nuts onto the spare tire support bracket.
- 2.) Remove (4) bolts securing the factory cross member or hitch to the frame rail with a 21mm socket. Set hardware aside for reuse during CURT hitch installation.

Note: The bumper shares the same mounting points and should be supported from underneath.

- 3.) Check to be sure that all wiring clears and slowly pull factory cross member or hitch downward and remove from vehicle. Clean weldnuts as needed with lubricant and brush. Replace with CURT hitch, which will mount in the space between the frame and the bumper mounting plates.
- 4.) Using the existing mounting hardware, attach the bottom mounting bolts (2 places each side) and loosely secure so that bumper placement adjustments can be made. Adjust bumper position to align with side mounting holes and secure remaining (4) bolts with a 21mm socket.
- 5.) Torque all M14 bolts to 126 ft-lbs.
- 6.) Reinstall all bolts loosened / removed in step 1. Raise the spare tire back into position.

PERIODICALLY CHECK THIS RECEIVER HITCH TO ENSURE THAT ALL FASTENERS ARE TIGHT AND THAT ALL STRUCTURAL COMPONENTS ARE SOUND.