

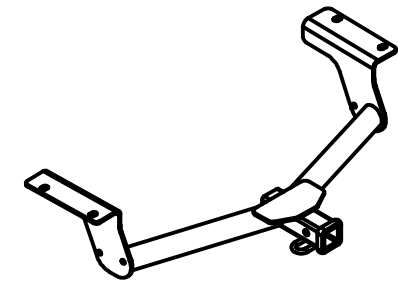

# Class III Receiver Hitch

## Part No. 69470C



**Fits: TOYOTA RAV 4 (EXCLUDING ELECTRIC)**



**GROSS LOAD CAPACITY WHEN USED AS A WEIGHT CARRYING HITCH: 3,500 LBS. TRAILER WEIGHT & 525 LBS. TONGUE WEIGHT.**  
**GROSS LOAD CAPACITY WHEN USED AS A WEIGHT DISTRIBUTION HITCH: 4,000 LBS. TRAILER WEIGHT & 525 LBS. TONGUE WEIGHT**



**WARNING: \*\*\* DO NOT EXCEED VEHICLE MANUFACTURER'S RECOMMENDED TOWING CAPACITY. \*\*\***

Parts List			
ITEM	QTY	PART NUMBER	DESCRIPTION
1	4	M12-1.25 x 35mm	HEX BOLT
2	4	1/2"	CONICAL TOOTHED WASHER

TOOLS REQUIRED
17, 19mm SOCKET
8" EXTENSION
SOCKET WRENCH
TORQUE WRENCH

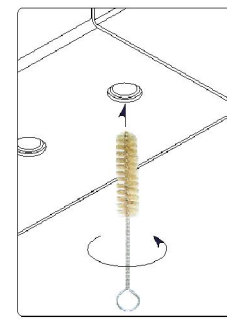

### WELDNUT CLEANING

To remove debris from weldnuts in frame, spray lubricant or compressed air into hole. For heavy debris, use a small wire brush. (Be careful not to damage threads).

### RUBBER ISOLATOR REMOVAL DIAGRAM

This technique can be used if an Exhaust Hanger Removal Pliers is not available.

Using a 5/8" open end wrench, slide the wrench up to the rubber isolator, cradling the hanger rod as shown. Next place the flat edge of a pry bar between the wrench and the hanger stop or hanger rod. Then simply rotate the pry bar toward the wrench to remove the rubber isolator.

Note: Using a spray lubricant or soapy water on the hanger rod and the rubber isolator helps removal.

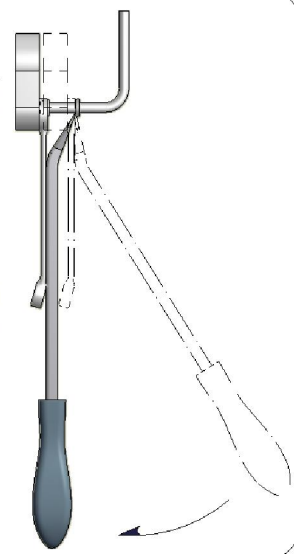

### PANEL TRIM DIAGRAM

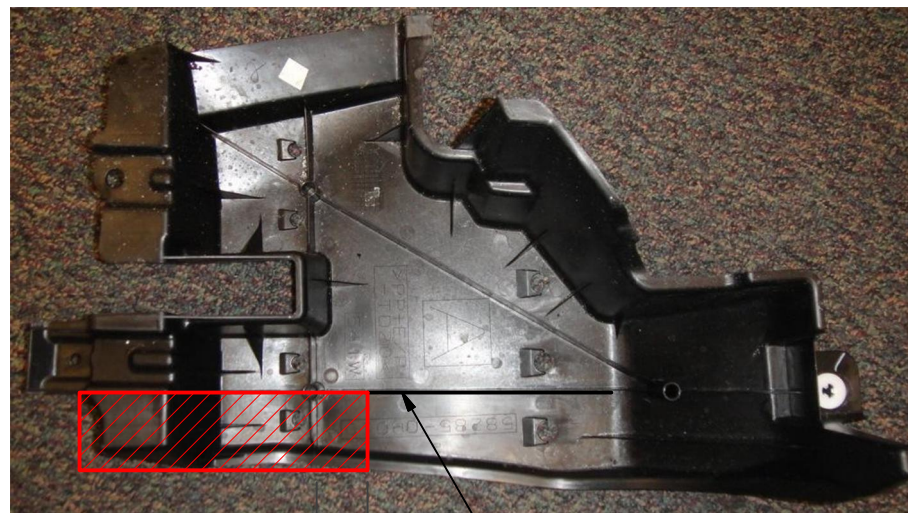

1.500 in → ← USE RIB AS GUIDE

### CONICAL TOOTHED WASHER ORIENTATION DIAGRAM

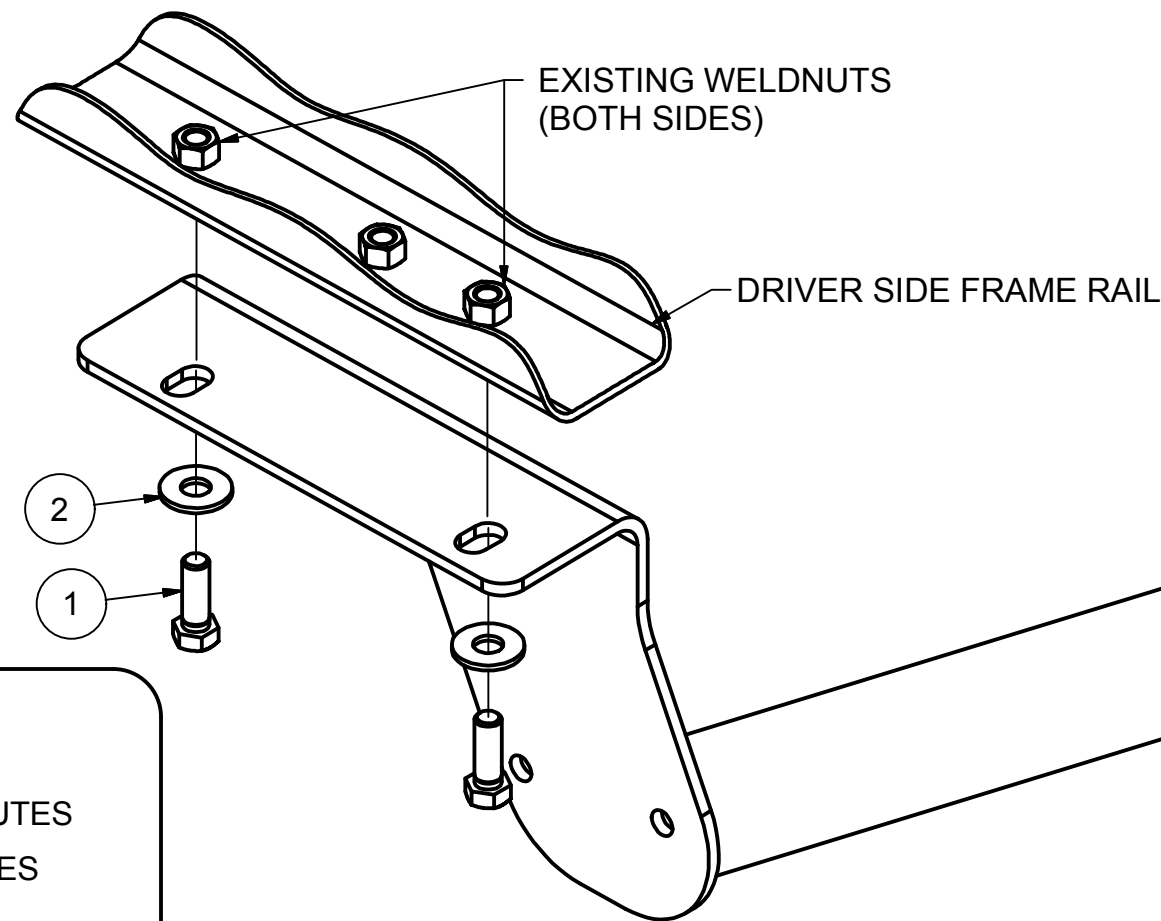
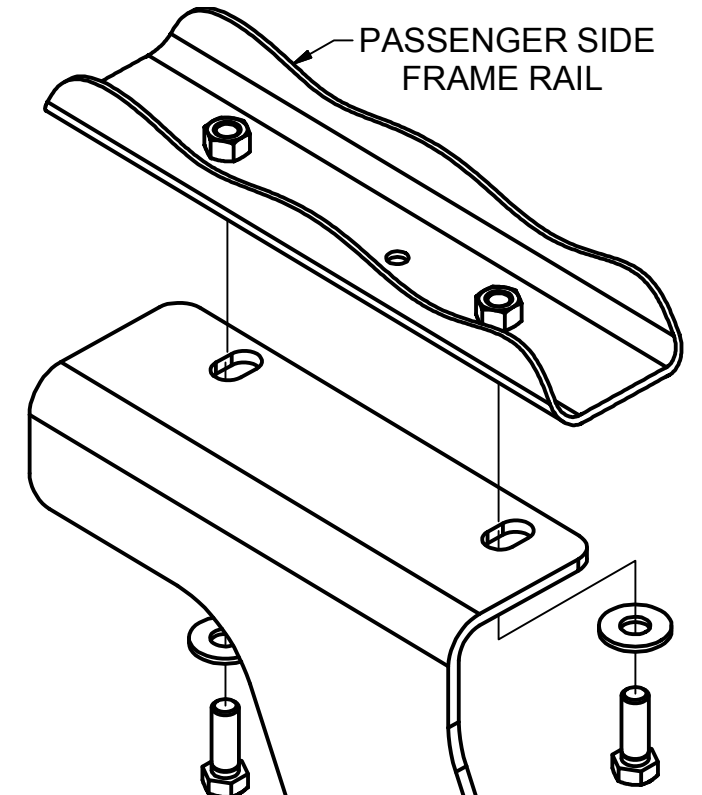
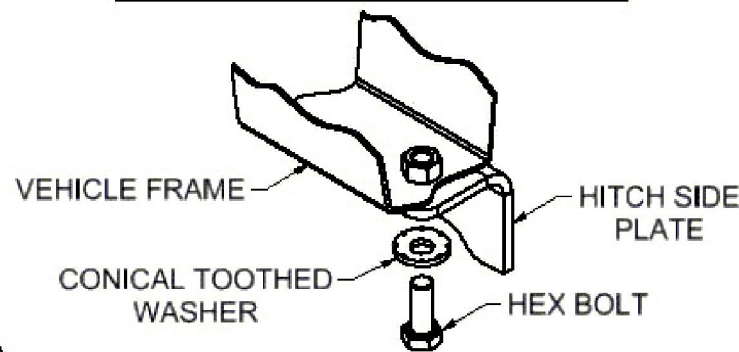

**FRONT** ↑  
**REAR** ↓

HITCH WEIGHT: 34 LBS.

### INSTALL TIME

PROFESSIONAL: 15 MINUTES

NOVICE (DIY): 30 MINUTES

### INSTALL NOTES:

- EXISTING WELDNUTS
- NO DRILLING REQUIRED
- REMOVE TIE DOWN BRACKET
- LOWER EXHAUST

## INSTALLATION STEPS

1. If present remove panel and trim using panel trim diagram above as reference. Remove tie down bracket from the driver's side of the vehicle and return to vehicle owner.
2. Lower rear most exhaust isolator for ease of installment.
3. Raise hitch into position over existing weldnuts and install the supplied 12mm hex bolts and conical tooth washers as shown.
4. Raise exhaust back into location and reinstall rubber isolator.
5. Torque hardware to 86 lb-ft.

**PERIODICALLY CHECK THIS RECEIVER HITCH TO ENSURE THAT ALL FASTENERS ARE TIGHT AND THAT ALL STRUCTURAL COMPONENTS ARE SOUND.**

Keystone Automotive Operations Inc., warrants this product to be free of defects in material and/or workmanship at the time of retail purchase by the original purchaser. If the product is found to be defective, Keystone Automotive Operations Inc., may repair or replace the product, at their option, when the product is returned, prepaid, with proof of purchase. Alteration to, misuse of, or improper installation of this product voids the warranty. Keystone Automotive Operations Inc.'s liability is limited to repair or replacement of products found to be defective, and specifically excludes liability for incidental or consequential loss or damage. This product complies with safety specifications and requirements for connecting devices and towing systems of the state of New York, V.E.S.C. Regulation V-5 and SAE J684. For Technical & Warranty Support: 1-877-544-4449 Fax- 1-855-242-8922 [www.huskytow.com](http://www.huskytow.com)

11202017