



# CLAMP-ON SWAY CONTROL BALL MOUNT

**Part # 38964**

**Dealer / Installer:** Provide a copy of these Instructions to the end user of this product. These Instructions provide important operating and safety information for proper usage of this product. Demonstrate the proper use of the product with the end user. Have the end user demonstrate that they understand the proper use of the product.

**End User:** Read and follow all instructions included in this manual. Ask your Dealer / Installer for assistance if you do not understand the proper use of the product. Never remove any decals from the product.

### PARTS INCLUDED

#	DESCRIPTION	QTY	#	DESCRIPTION	QTY
1	BALL PLATE ASSEMBLY	1	4	3/8"-16 NUT	4
2	BACKING PLATE	1	5	3/8" WASHER	4
3	3/8"-16 X 3-1/2" HEX BOLT	4			

**IMPORTANT:** THIS PRODUCT IS **ONLY** INTENDED FOR USE WITH 2" TO 2-3/4" TRAILER FRAMES.

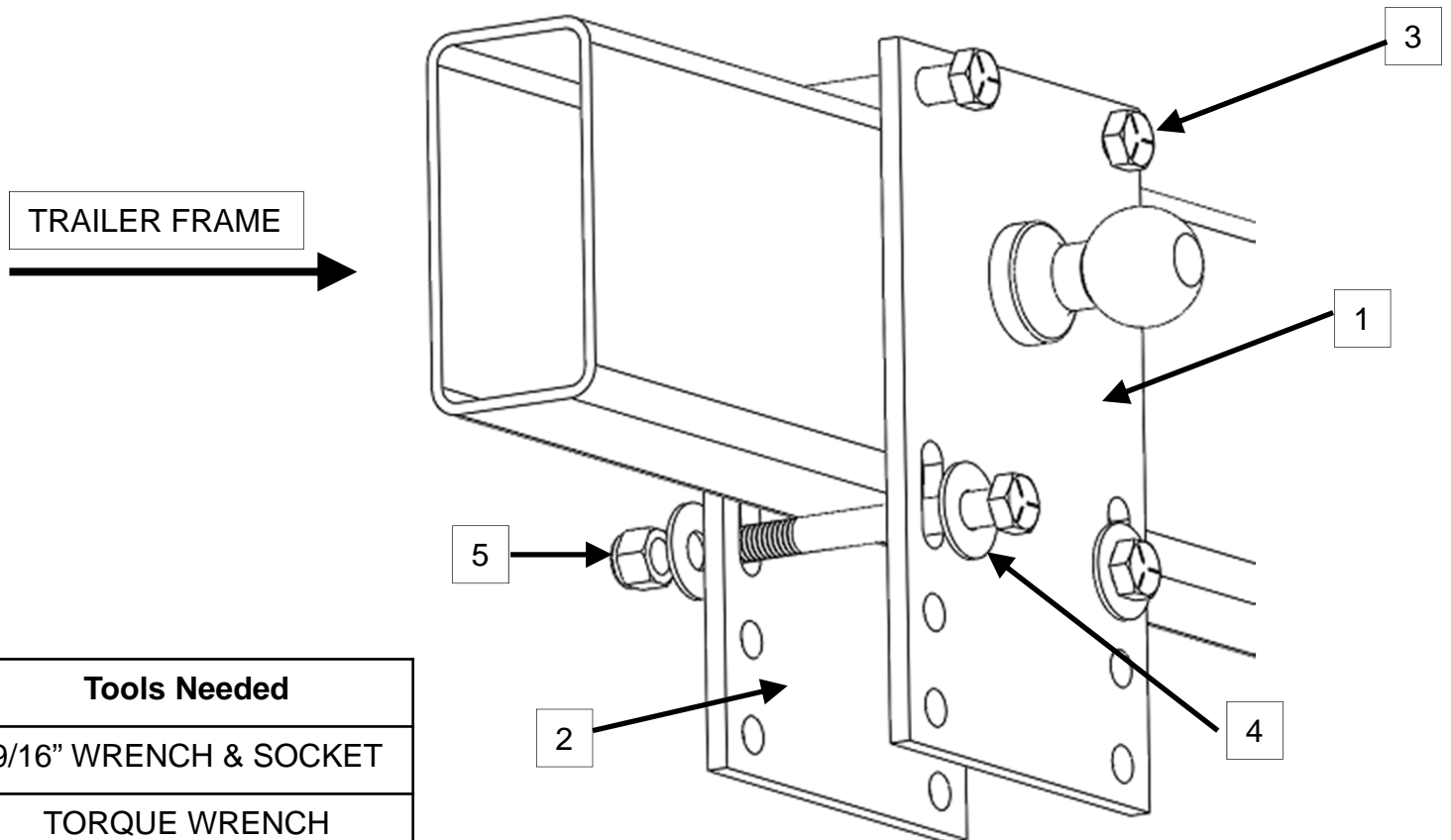

Tools Needed
9/16" WRENCH & SOCKET
TORQUE WRENCH

1: Assemble ball plate assembly (#1) and backing plate (#2) with the two 3/8" hex bolts (#3) and two 3/8" lock nuts (#4) in the upper two holes in both plates. See Fig. 1

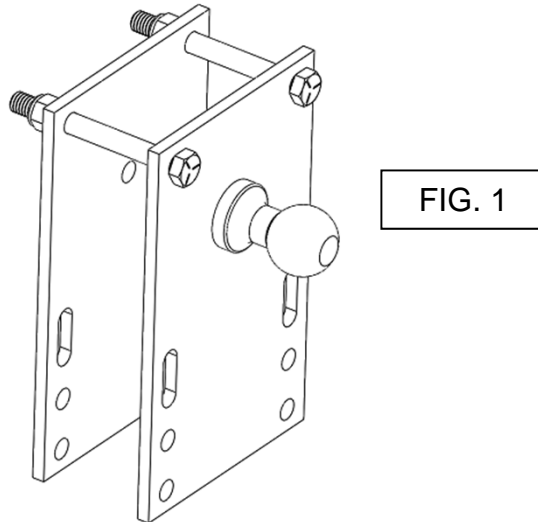

2: Position the assembly over the trailer frame and place it so that the ball is the correct distance from the hitch sway control ball. See Fig. 2A. See sway control instructions for the correct distance. For the Husky Friction Sway Controls part # 34715 & 37498; measure 24" from the center of the coupler ball socket down the side of the frame to the center of the ball on the ball plate assembly (#1). See Fig. 2B.

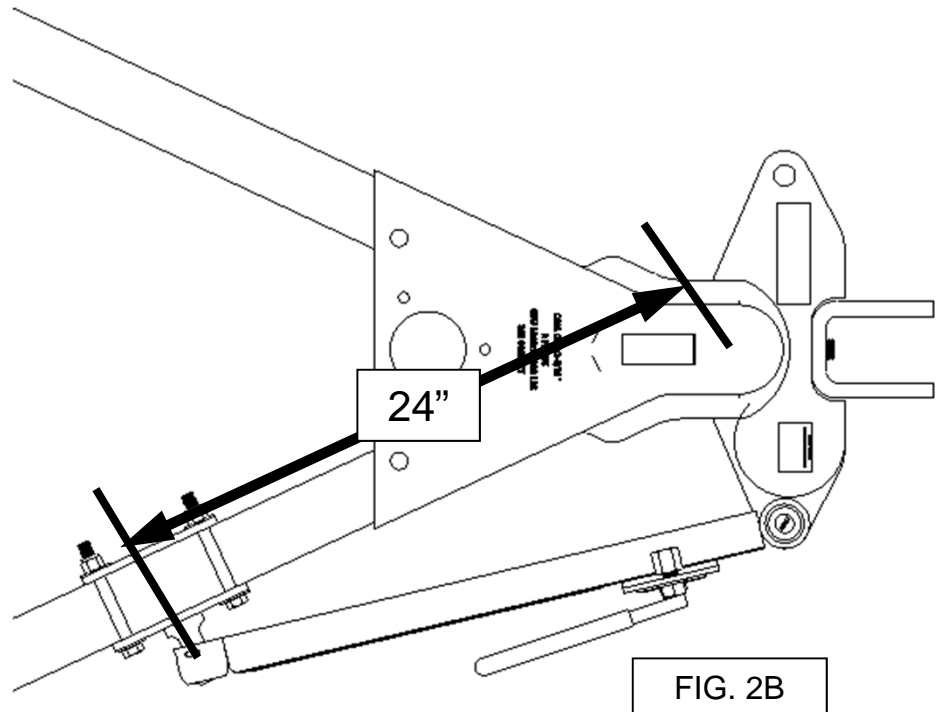
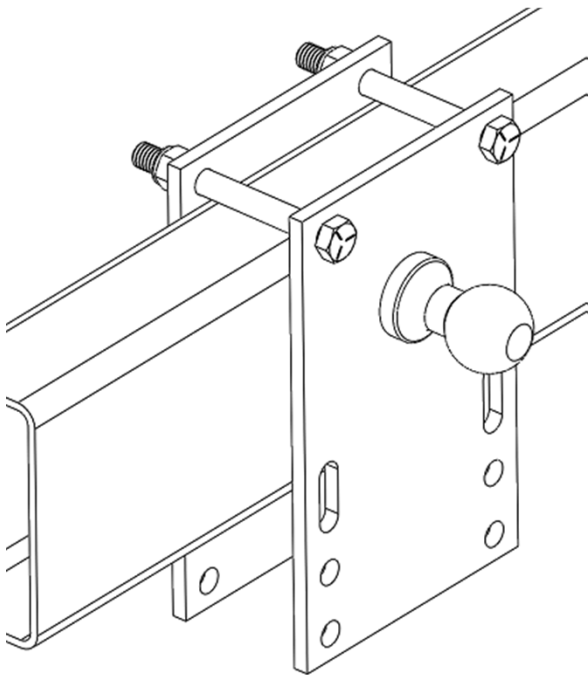

3: Insert the remaining two 3/8" hex bolts (#3) and two 3/8" lock nuts (#4) through lower holes or slots. The 3/8" hex bolts MUST be placed as close to the bottom of the trailer frame as possible. See Fig. 3.

PLACE THE 3/8" FLAT WASHERS (#5) UNDER THE HEAD OF THE 3/8" HEX BOLTS (#3) AND 3/8" LOCK NUTS WHEN THE SLOTS IN THE BALL PLATE ASSEMBLY (#1) AND THE BACKING PLATE (#2) ARE USED. See Fig. 3.

4: Tighten ALL 3/8" hardware to 30 ft. lbs.

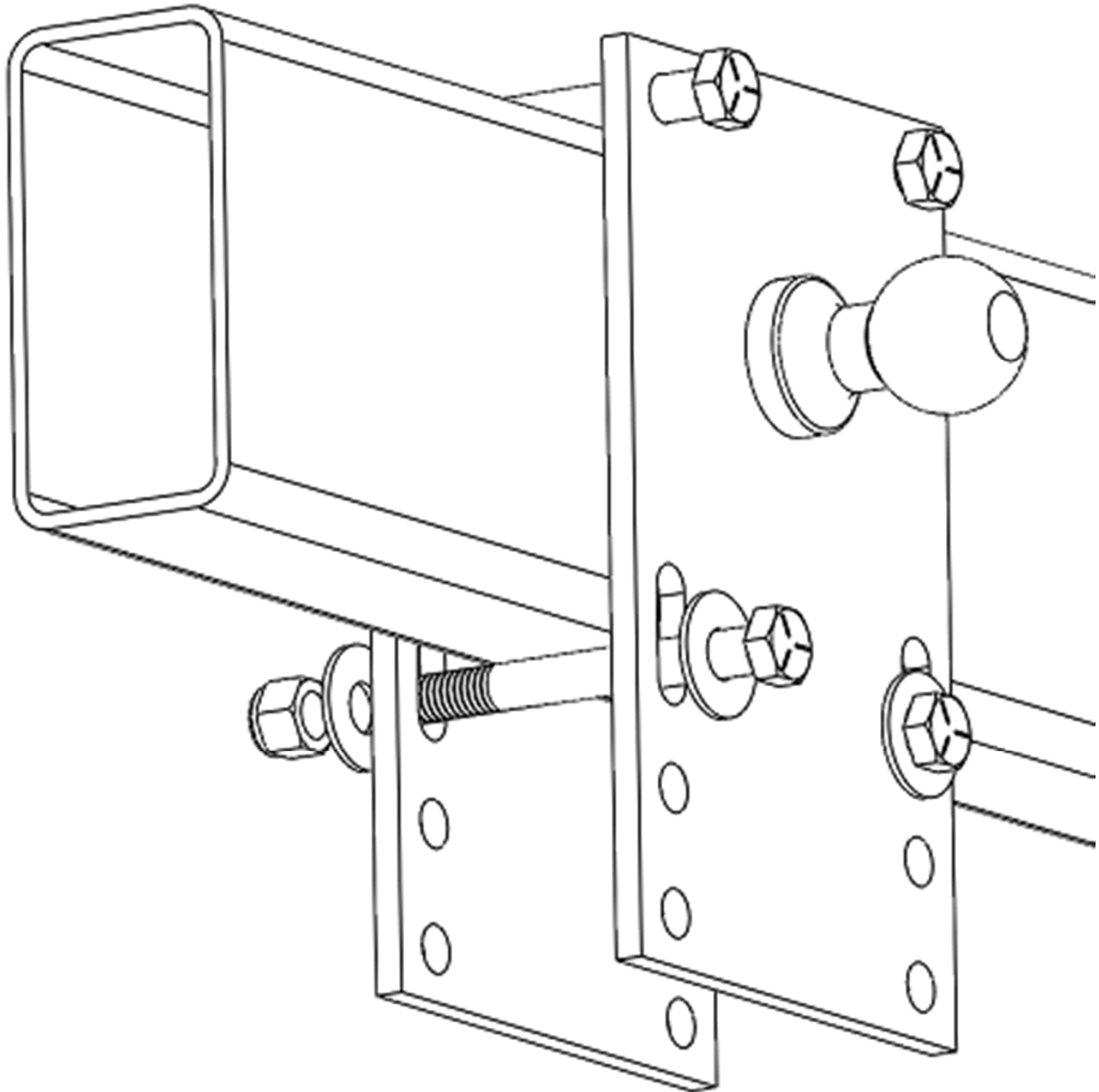

FIG. 3