



Assembly, Installation, Operation and Maintenance Instructions

P/N: 33006

FORD 5TH WHEEL ADAPTOR

Dealer / Installer:	Provide a copy of these Instructions to the end user of this product. These Instructions provide important operating and safety information for proper usage of this product. Demonstrate the proper use of the product with the end user. Have the end user demonstrate that they understand the proper use of the product.
End User:	Read and follow all instructions included in this manual. Ask your Dealer / Installer for assistance if you do not understand the proper use of the product. Never remove any decals from the product.

APPLICATION:

Ford F250/350 years 2011 to Current – vehicle must have OEM 5th wheel/Gooseneck Hitch Prep Package

This kit is to be used **ONLY** with Husky 5TH Wheel Kits:

31664 (HUSKY 16KS / CROSSMEMBER WITH HUSKY 16K UPRIGHTS)
31313 & 31314 (HUSKY 16KS / CROSSMEMBER WITH HUSKY 16K UPRIGHTS)
31666 (HUSKY 16KW / CROSSMEMBER WITH HUSKY 16K UPRIGHTS)
31326 & 31314 (HUSKY 16KW / CROSSMEMBER WITH HUSKY 16K UPRIGHTS)

WARNING

THE 33006 FORD 5TH WHEEL ADAPTOR LIMITS ALL 5TH WHEEL CAPACITIES TO 16,000 LBS. GVWR AND 4,000 LBS. PIN WEIGHT OR LESS.
DO NOT EXCEED 16,000 LBS. FOR ANY 5TH WHEEL HITCH. NO NOT EXCEED VEHICLE TOWING LIMITS.
READ YOUR OWNERS MANUAL.

WARNING:

If the truck is raised, be sure that the truck is properly blocked and restrained to prevent the truck from falling. Failure to do so may result in the truck suddenly falling, causing death or serious injury.

CAUTION:

These instructions are guidelines only. Actual installation is the responsibility of the installer and the owner. Always measure truck and trailer before installing hitch to be sure that there is clearance at the cab and at the bumper to allow for turns.

Use only the supplied bolts, nuts, and washers to install this kit. All nuts and bolts are Grade 5 unless specified otherwise.

WARNING

Failure to follow ALL of these instructions may result in death or serious injury

WARNING

This product is **NOT** to be used with rotating pin boxes or pin boxes that require a “wedge”; such as the REESE Sidewinder, REESE Revolution, 5th Airborne Sidewinder. Use of these products may damage this product and will void the warranty.

NOTICE

Husky recommends to always drive the king pin into the hitch throat and not drop the king pin from above into the hitch head to avoid incorrect hook-ups. Please read Operating Instruction to understand how this important Safety Feature operates.

Parts Diagram

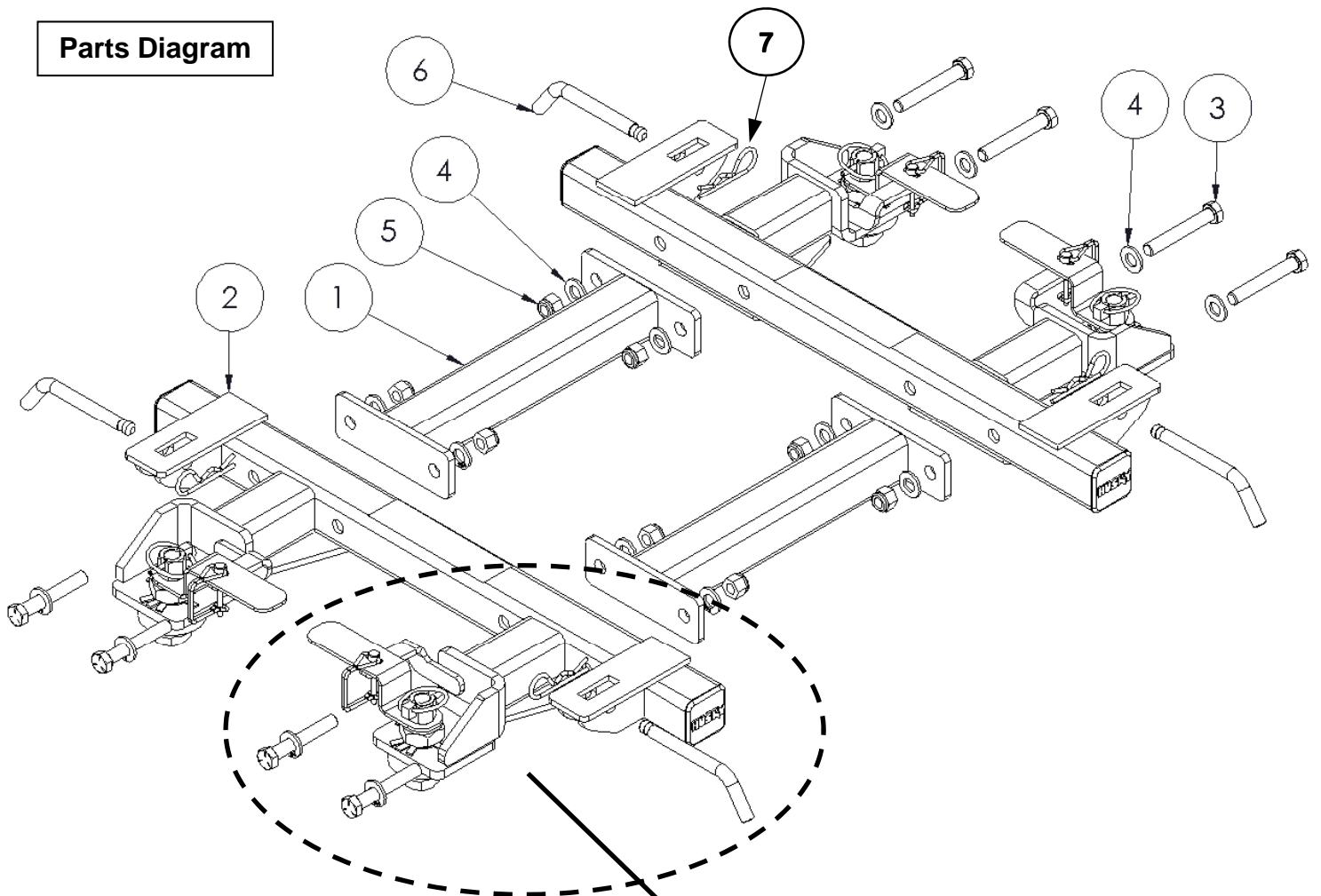

PARTS LIST		
ITEM NO.	DESCRIPTION	QTY.
1	CENTER SUPPORTS	2
2	ADAPTOR RAIL	2
3	1/2-13 X 3-1/4" HEX HEAD BOLT	8
4	1/2" FLAT WASHER	16
5	1/2-13 NYLOCK NUT	8
6	1/2" BASE RAIL PIN	4
7	SPRING CLIP	4
8	1-14 JAM NUT	4
9	TAB WASHER	4
10	HANDLE	4
11	3/16" LOCK PIN	4
12	FORD PUCK ADAPTOR	4
13	FORD OEM T-BOLT	4
14	HUSKY PLUG	4
15	3/16" SPRING LOCK PIN	4

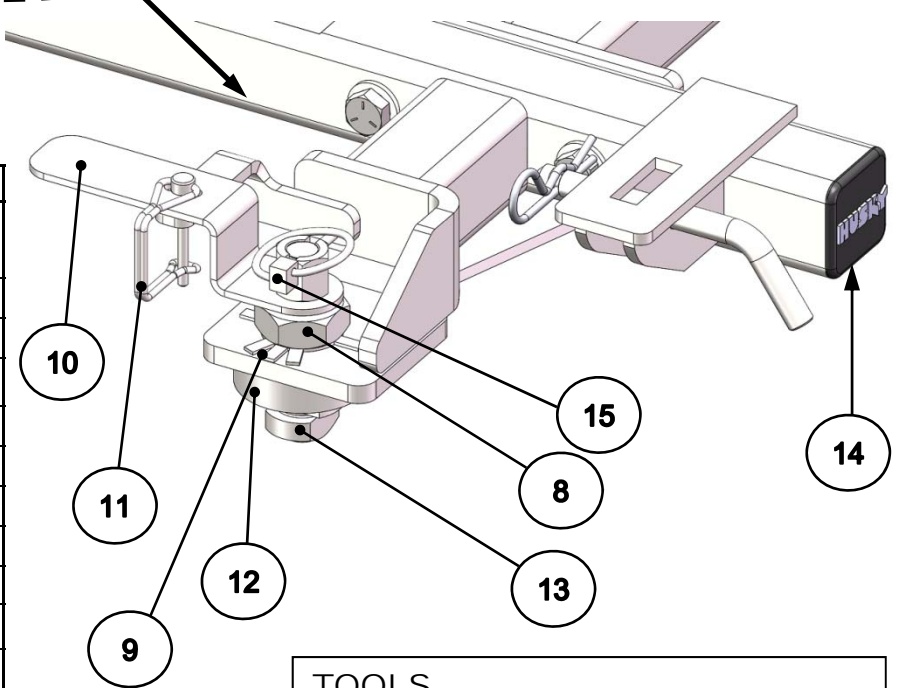

TOOLS
 3/4" Socket & Open End Wrenches.
 Torque Wrench capable of 75 ft.lbs.
 1-1/2" Open end or adjustable wrench.
 Flat blade screwdriver.

1. Assemble Center Supports to Adaptor Rails using the ½” hardware as shown. Torque ½” hardware to 75 ft./lbs. See parts diagram on page 2 for details.
2. Place the assembled Adaptor into the Ford 5th Wheel “pucks” installed in your truck from the factory. The handles and T-bolts must be rotated into the Un-locked position.

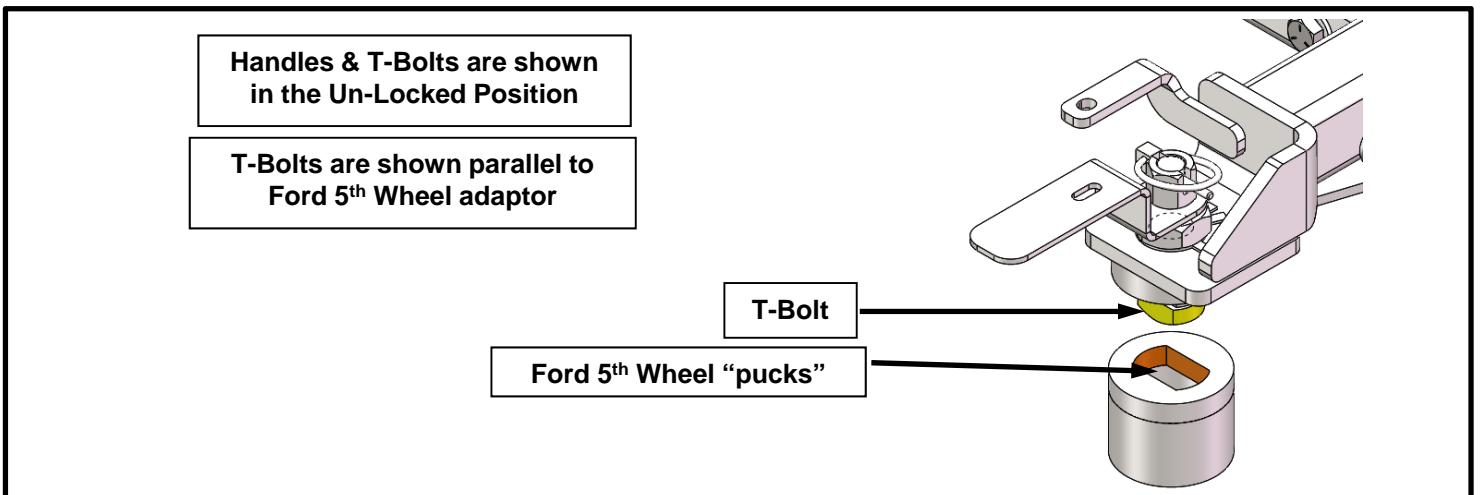
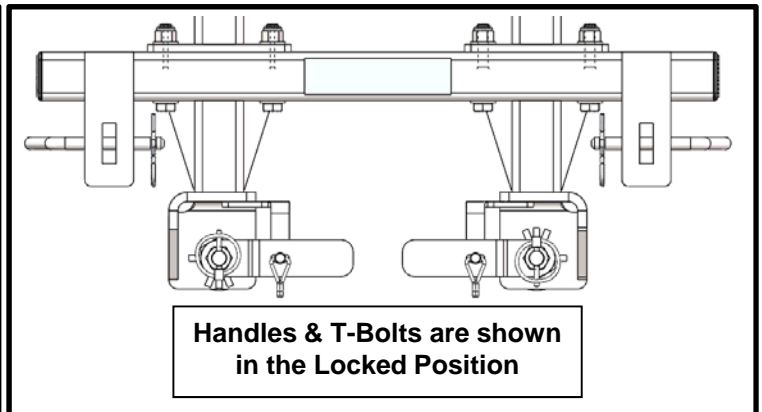
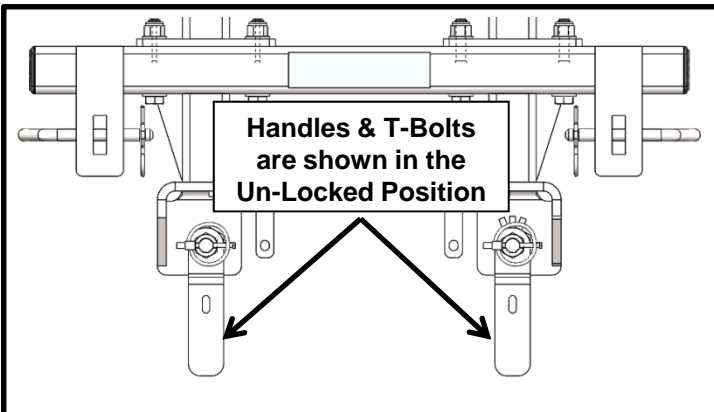
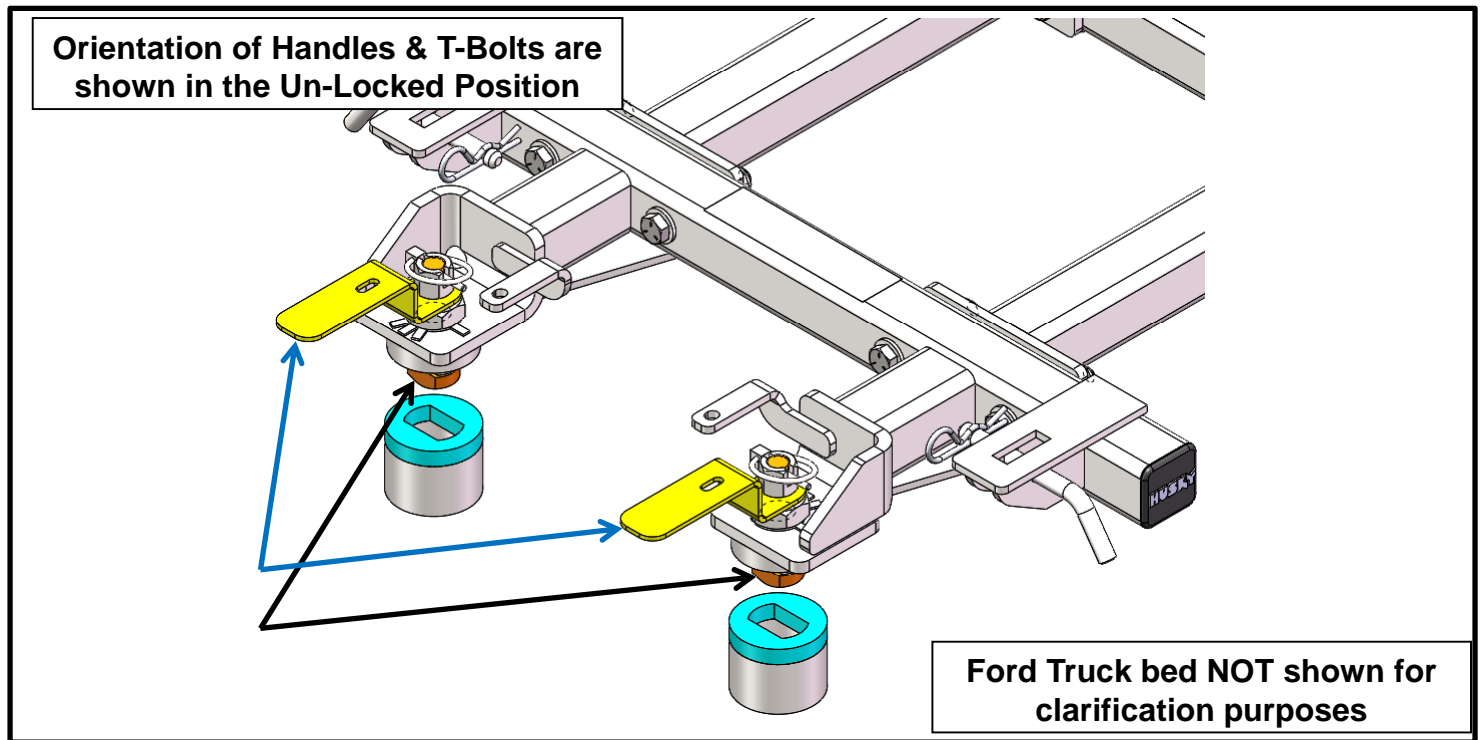

- Once the Adaptor is installed; turn handles into the locked position. This may require adjusting the T-bolts for a looser or tighter fit.

**Handles and T-Bolts are shown
in the Locked Position**

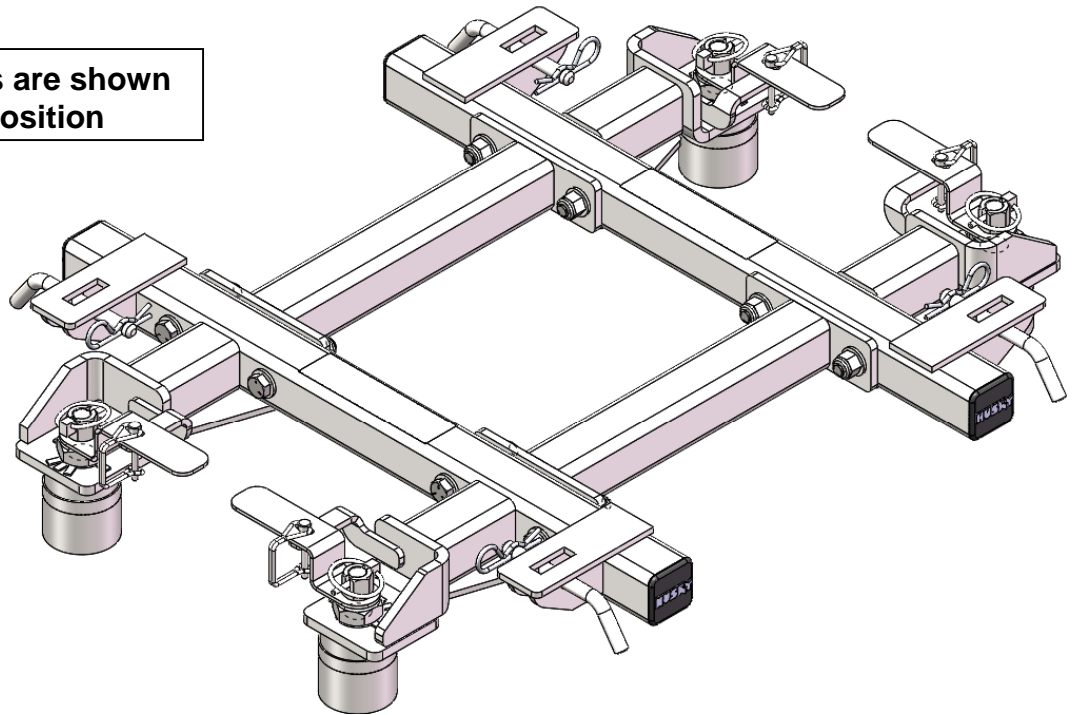

- Once the Adaptor is installed; make sure the Adaptor Rails (#2) sit **FLAT** with the Ford 5th Wheel “pucks” at **ALL** 4 contact locations.

**Handles & T-Bolts are shown
in the Locked Position**

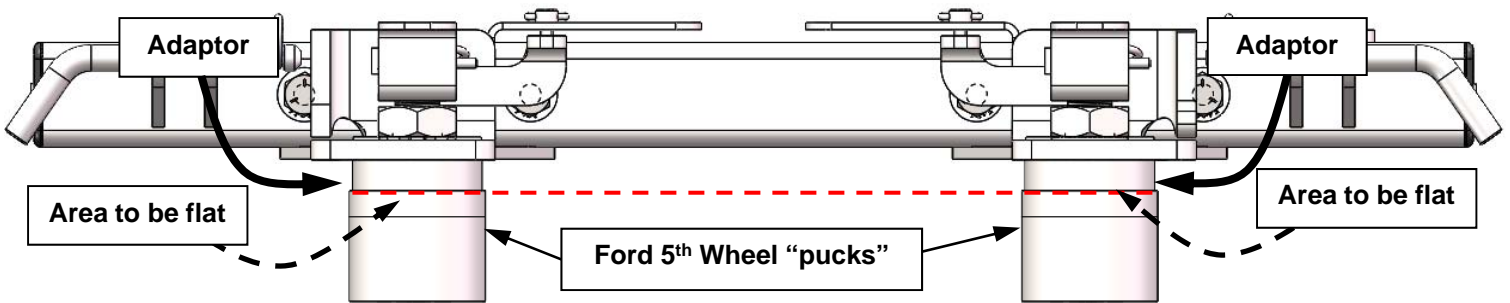

- Rotate handles to the locked and unlocked positions. All 4 handles should rotate easily. Check to be sure that the Adaptor does **NOT** “rock” back and forth easily and that the Adaptor Rails remain **FLAT** with the Ford 5th wheel “pucks”. If the handles do not rotate easily **OR** if the hitch assembly “rocks” and does not stay flat; you need to adjust the T-bolts up or down by rotating them in the handles. We recommend you do this in half turn increments. Plus, this may take a few times to get adjusted correctly. All trucks are not made the same and require different amounts of adjustment. **Be PATIENT.**
- Rotate handles to the unlocked position and remove the assembled Adaptor from the Ford 5th wheel “pucks”. **IF** the Adaptor does **NOT** remove easily; loosen the 1” jam nuts (6) and adjust the Adaptor Rails so that the assembled Adaptor removes easily. Re-tighten the 1” jam nuts.
- Once the Adaptor removes easily, the handles rotate easily **AND** there is no “rock” in the assembled Adaptor with the Ford 5th Wheel “pucks” you can tighten the 1” jam nuts with an adjustable wrench until tight.

8. Bend 1 of the tabs on each of the tab washers (#9) up and against the side of the jam nut. This will keep the 1" jam nut from loosening.

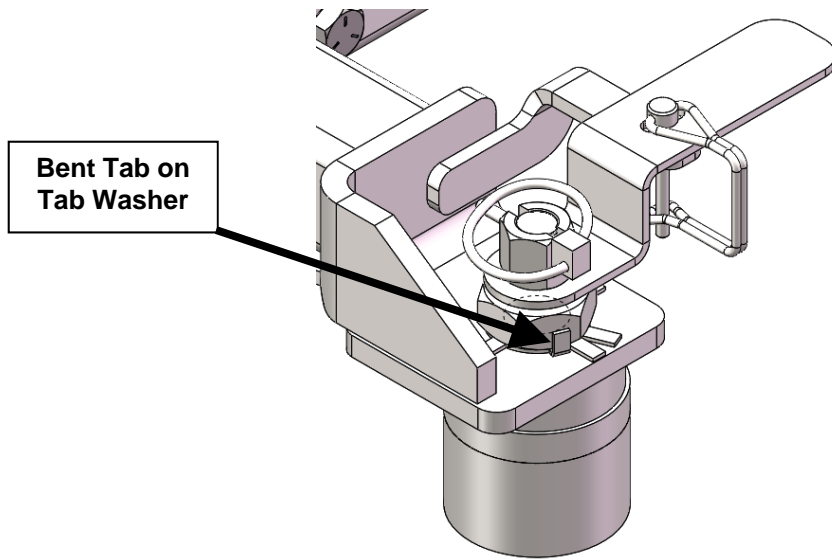

9. Finally, install the 3/16" D-Lock pins (#11) through the handles and the uprights.

WARNING: NEVER TOW WITHOUT LOCKING THE 5TH WHEEL HITCH HANDLES WITH EITHER THE PROVIDED 3/16" D-LOCK PINS OR A PAD LOCK

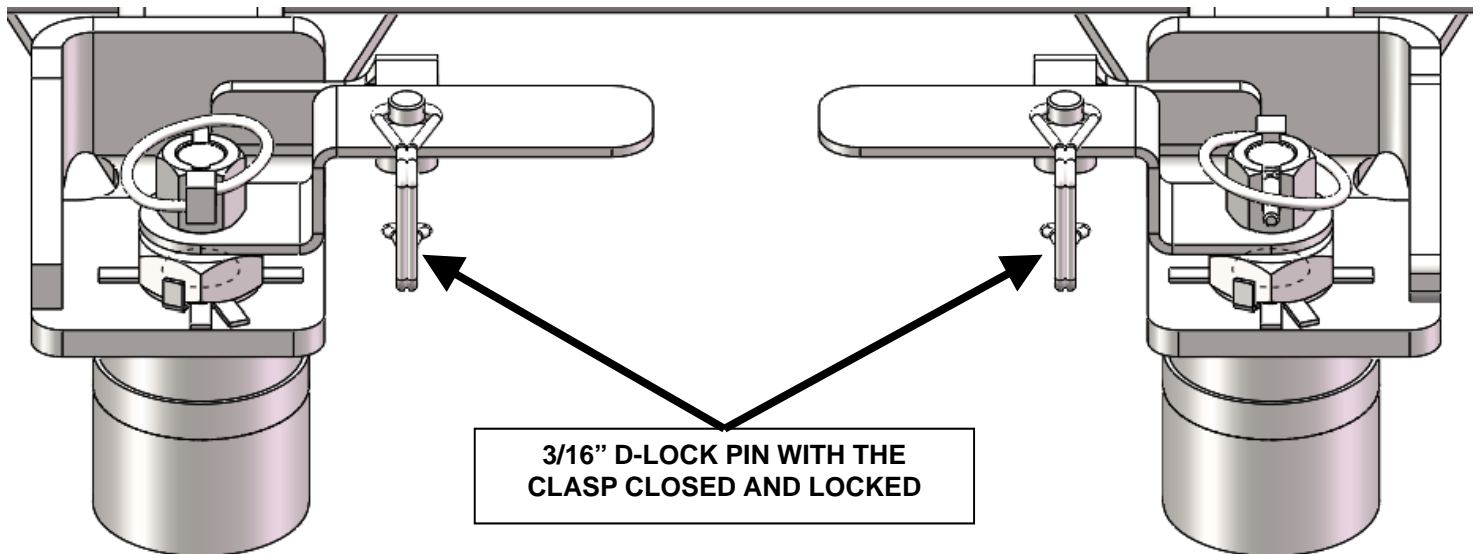

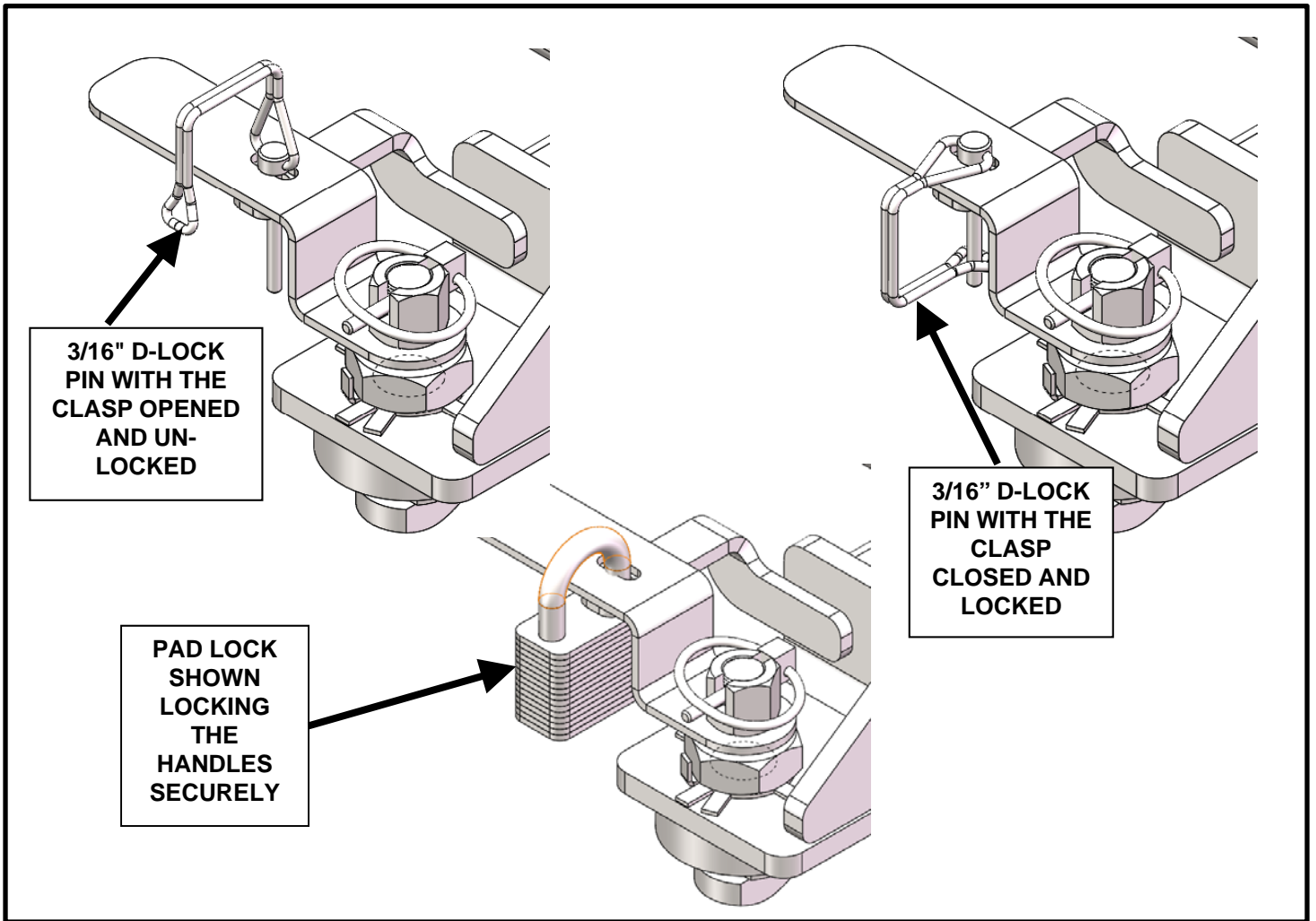

10. Install the recommended HUSKY 5th Wheel (or Roller) according to the provided instructions to that specific product. See and visit www.huskytowing.com, for the latest instructions.

11. Add base pins and spring clips through all 4 feet of the 5th wheel and the Ford 5th wheel adaptor as shown.

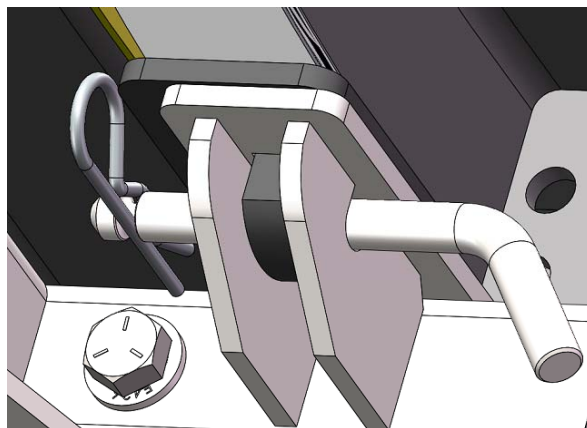
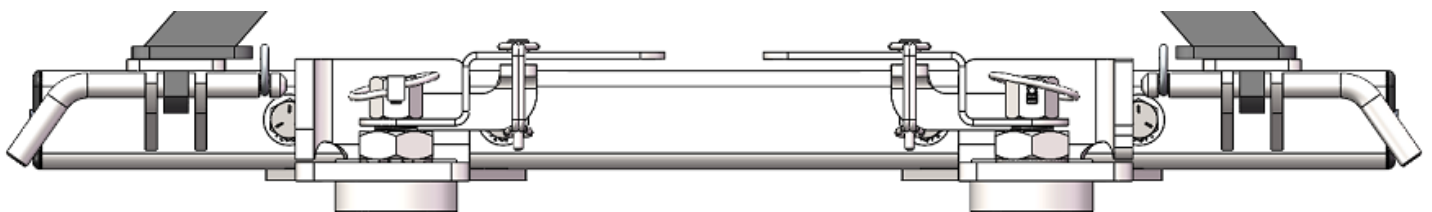

Preparing For First Use

1. Verify that the cross member is set at the proper height to provide a minimum of 6" clearance between the bottom of the trailer nose and the top of the truck bed sides, and allows for a level-towing attitude of the 5th Wheel Trailer (See Figure 1 below).

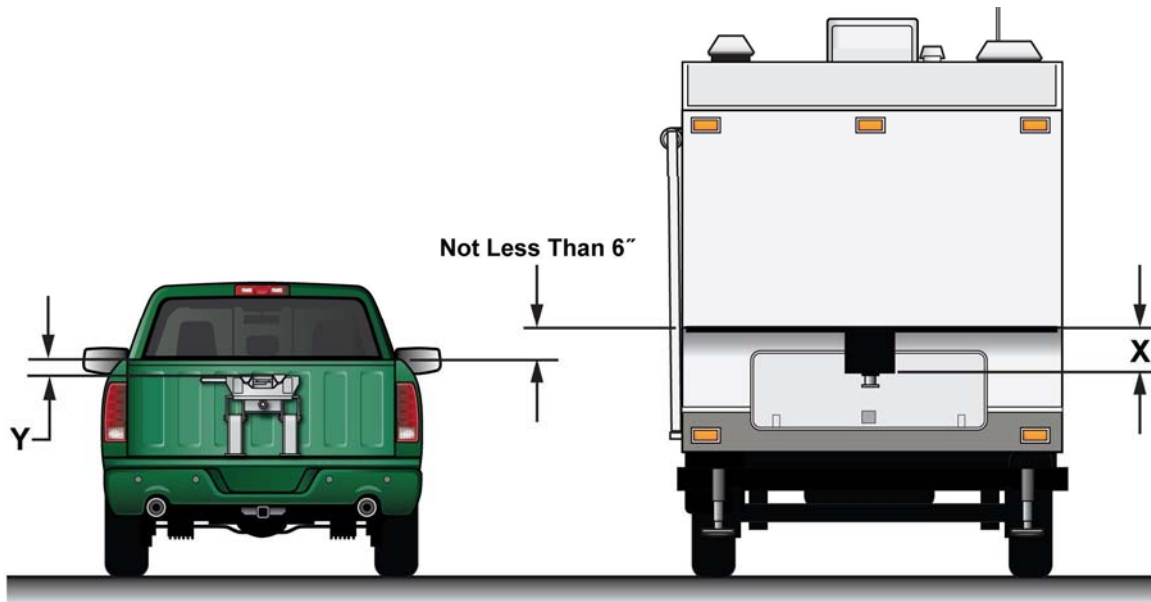

2. With top face of head level measure up to top of pickup box (dimension Y in Figure 1). On the trailer measure up from the face of the pin box to the underneath of the trailer (dimension X in Figure 1). Measurement X less measurement Y gives the amount of clearance between the top of the pickup box and the underneath of the trailer. At a minimum this should be 6", if the trailer and tow vehicle are going off-road then this needs to be 8" to 10".

If this dimension is less than 6" DO NOT USE THIS TRAILER WITH THIS TOW VEHICLE. Severe damage may occur to both the pickup box and the trailer.

3. If necessary, adjust the cross member to the proper height, ensuring the fasteners are re-torqued to the specified values provided by the manufacturer.
4. Ensure the 5th Wheel Trailer wheels are blocked front & rear & that the rear stabilizer jacks are fully retracted.
5. Also make sure the 5th Wheel Trailer landing leg feet are on a stable surface.
6. With hitch head level, set trailer king pin box $\frac{1}{2}$ " to 1" below hitch so trailer will ride up and onto hitch. Back Up the truck under the trailer so the king pin enters the hitch.

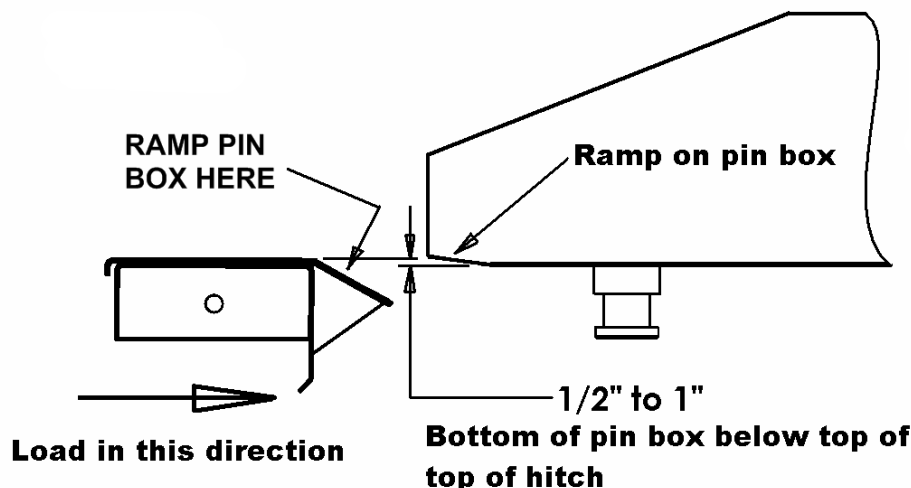

7. Open the handle to your 5th wheel according to the instructions provided to that specific product.
8. Slowly back the truck so that the bottom plate of the king pin box slides onto the 5th wheel plate & the king pin slides fully into the throat of the hitch head. Set the parking brake of the truck & place the transmission into park.
9. Visually verify that the 5th jaw or slide bar has closed behind the king pin and the king pin box is resting on the 5th wheel plate. Positively lock the slide bar by rotating the handle clockwise so the handgrip is pointing straight down at the bed of the truck. The red indicator sleeve on the handle shaft should not be visible when correctly hitched up and the green indicator shaft should be protruding from the side of the hitch head.

Warning! Never back the tow vehicle under the trailer king pin and then lower the king pin into the hitch. This will result in high pinning and will result in hitch damage and possible vehicle damage, injury or death!

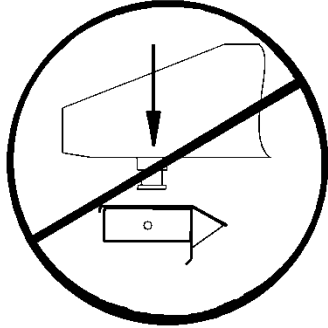

**NEVER LOWER THE TRAILER
ONTO THE HITCH**

NEVER LOWER THE KING PIN INTO THE HITCH USING THE TRAILER JACKS. THIS IS A VERY DANGEROUS PRACTICE AND WILL RESULT IN THE KING PIN SITTING ON TOP OF HITCH INSTEAD OF INSIDE. THE TRAILER COULD THEN BECOME DETACHED FROM THE TRUCK DURING TOWING CAUSING SERIOUS DAMAGE AND POSSIBLY INJURY OR DEATH.

10. **Before towing perform a tug test as follows:** Ensure the landing gear of the 5th Wheel Trailer are extended to the ground, chock the tires, and attach the electrical & breakaway connectors to the proper receptacles in accordance with your 5th Wheel Trailer owner's manual. Then apply the trailer brakes, and slowly try to pull the trailer forward. The trailer should prevent the truck from moving.
11. Remove the blocks from the wheels of the 5th Wheel Trailer; fully retract the trailer jacks and double check that the hitch is properly attached to your tow vehicle.

Uncoupling Your Trailer

1. Block your 5th Wheel Trailer wheels front & rear.
2. If necessary, start your truck & back up against the king pin to relieve pressure on the 5th wheel jaw. Set the parking brake, put the transmission into park and then turn off your vehicle.
3. Extend the landing gear of the 5th Wheel Trailer until the weight of the 5th Wheel Trailer is just off of the 5th wheel plate of the hitch. Do not exceed 1/16" gap between the bottom plate of the king pin box and the tabletop of the hitch. **Caution: Raising the 5th Wheel Trailer too high while still connected can damage the hitch head as well as components of your 5th Wheel Trailer. Do not extend the rear stabilizers of the 5th Wheel Trailer prior to or during uncoupling.**
4. Disconnect the electrical and breakaway connectors in accordance with your 5th Wheel Trailer owner's manual.
5. You are now ready to pull your truck slowly away from the 5th Wheel Trailer..

WARNING

DO NOT TRIP THE HITCH MECHANISM BY HAND AS THIS CAN RESULT IN INJURY . IN NORMAL OPERATION LEAVE THE HITCH OPEN UNLESS IT IS COUPLED TO A TRAILER.

ALWAYS PULL ON THE HANDLE TO OPEN THE HITCH BEFORE COUPLING THE TRAILER.

Maintenance

1. After coupling, always visually check that the 5th wheel jaw or slide bar has closed completely across the rear of the king pin and that the indicators are working properly.
IMPORTANT! All indicating features should work when you are done hitching up for travel.
2. After the first 100 miles, and at least once a year thereafter, inspect all bolts for proper tightness. Re-tighten nuts if needed.
3. Once or twice a week when traveling, apply a few drops of lubricant to the pivot areas of the hitch.
4. Once or twice a year, apply a light coating of wheel bearing grease to the surfaces of the slide bar that holds the king pin in place. For best results, apply the grease with the slide bar or jaw surfaces of the 5th wheel in the closed position.

Caution: The 5th wheel jaw or slide bar can close with heavy force. Use extreme care to keep fingers, hands, extremities & clothing out of the path of the slide bar. Failure to do so could result in severe injury.

5. Periodically inspect your product for wear or damage. If excessive wear or damage is found, contact your installing dealer or HUSKY technical support staff at www.huskytow.com or 1-877-544-4449.
6. Husky Towing Products recommends the use of a lube disc, contact your local Husky dealer to purchase one.

TOWING TIPS

Driving Tow Vehicle

Good habits for normal driving need extra emphasis when towing a trailer. The additional weight of the trailer affects acceleration and braking. Extra time should be allowed for passing, stopping and changing lanes. Signal well in advance of a maneuver to let other drivers know your intentions. Severe bumps and badly undulating roads can damage your towing vehicle, hitch and trailer, and should be negotiated at a slow, steady speed. If any part of your towing system “bottoms out” or if you suspect damage may have occurred in any other way, pull over and make a thorough inspection. Correct any problems before resuming travel.

Turning and backing up present new problems-plan ahead. It is highly recommended that a spotter be used when backing up to alert the driver of possible obstacles and prevent jack knifing the trailer.

Towing a trailer will change your turning radius, the longer the trailer the larger radius turn.

Driving Conditions

When driving in conditions where the pavement is wet, icy, snowy, loose gravel, grass and dirt, reduce speed and do not make any sudden maneuvers. Allow ample distance/time for stopping and changing lanes. If possible, wait for road conditions to improve before driving.

Follow all state, local and provincial driving and towing laws in the location you are driving in.

Not following your tow vehicle, trailer, and Husky instructions/manuals can result in a fatal accident.

Check Your Equipment

Please refer to the MAINTENANCE section. Periodically check the condition of all your towing equipment and keep it in top condition.

Tire Inflation

Unless specified otherwise by the towing vehicle or trailer manufacturer, tires should be inflated to their manufacturer's towing recommendations.

Towing Vehicle and Trailer Manufacturers Recommendations

Review the owner's manual for your towing vehicle and trailer for specific recommendations, capacities and requirements.

Passengers in Trailers

Trailers should not be occupied while being towed. Most states enforce this regulation.

Trailer Lights, Turn Signals, Electric Brakes

Always hook up all of the trailer lights, electric brakes and break-away switch connection whenever trailer is being towed. Also periodically check functionality of all lights before towing and repair any problems as needed.

Remove Hitch When Not Towing

Remove hitch from the towing vehicle when not towing a trailer to reduce chances of accidental damage and to reduce the chance of parts being stolen.

Maintenance

Keep movable hitch assembly parts (jaw, pivot pin, etc...) lubricated when not in use.

Remove 5th wheel hitch from receiver and store in clean, dry place when not in use.

At The Beginning of Every Towing Day:

If electric brakes are used ensure the emergency break away cable is attached to the tow vehicle.

Check to see that all electrical hook-ups are in working order and that the safety chains are securely connected.

Towing safely is the responsibility of the driver of the vehicle. Failure to tow safely can result in vehicle damage, bodily injury or death.

Warranty Terms:

10 Year Limited Warranty:

This warranty applies solely to Husky 5th Wheel adaptor manufactured by DTS Manufacturing for Husky Towing Products.

Husky Towing Products and DTS Manufacturing make no guarantees or warranties for products not manufactured by DTS Manufacturing. Such products are covered solely under any applicable warranty of the manufacturer. It is always recommended that the operating instructions and guarantee instructions provided by the manufacturer are followed.

DTS Manufacturing warrants its products to be free from manufacturing and material defects to the original purchaser for the length of warranty stated above from the date of retail purchase. If any products are found to have a manufacturing or material defect, the product will be replaced or repaired at the option of Husky Towing Products and DTS Manufacturing with proof of purchase by the original purchaser. The original purchaser shall pay all transportation and shipping costs associated with the return of the defective product and the defective product shall become the property of DTS Manufacturing.

The Warranty applies to DTS Manufacturing products used for individual and recreational purposes. Commercial usage of the DTS Manufacturing products limits the warranty to 90-days from date of purchase.

The Warranty applies only to DTS Manufacturing products which are found to be defective in manufacturing or material. This warranty does not apply to normal wear and tear of the finished product placed on DTS Manufacturing products.

Husky Towing Products and DTS Manufacturing are not responsible for any labor costs incurred for removal or replacement of the defective product.

Husky Towing Products and DTS Manufacturing are not responsible for repair or replacement of any product under the limited warranty where the product was improperly installed, misapplied, altered, abused, neglected, overloaded, misused or damaged as a result of an accident, including any use of the product not in accordance with all product operating and safety instructions.

Without limiting the generality of the foregoing, Husky Towing Products and DTS Manufacturing shall under no circumstances be liable for any incidental or consequential loss or damage whatsoever arising out of, or in any way relating to any such breach of warranty or claimed defect in, or non-performance of the products. Some states do not allow the exclusion or limitation of incidental or consequential damages, so the above exclusion or limitation may not apply to you.

This limited warranty gives you specific legal rights, and you may also have other rights that vary from state to state.