

Installation Instructions

18-19 Jeep Wrangler JL
 Unlimited 4 Dr
 All Sub-Models

IS-8854_RevA



For proper installation and best possible fit, please read all instructions BEFORE you begin.
 For technical assistance or to obtain missing parts, please call Customer Relations at 1-800-328-2409.

Important Safety Information



- CAUTION - Before driving, ensure that the steps are properly secured to vehicle.
- Periodically check all components for tightness.

Before Installation

- Remove Contents and verify all parts are present.

Contents

NOTE: Actual product may vary from illustration.



Right Front



Right Front Support



Right Center

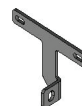

Right Center and Rear Support (2)



Right Rear



Left Front



Left Front Support



Left Center



Left Center and Rear Support (2)



Left Rear



Left Tube Step



Right Tube Step

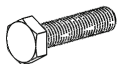

10mm x 30mm Bolt (6)



10mm Flat Washer (12)



10mm Nylock Nut (6)

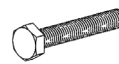

8mm x 35mm Bolt (6)



8mm Lock Washer (6)



8mm Flat Washer Bolt (6)



8mm Combo Bolt Bolt (12)



6mm x 25mm Bolt (12)



6mm Flat Washer (24)



6mm Nylock Nut (12)

Tools Required

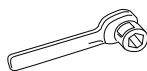

Socket Wrench



Socket Set

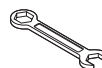

Wrench Set



Safety glasses

Installation

- 1 Remove any Factory or aftermarket steps or rock rails present on the vehicle.
- 2 Start installation toward the front of the driver side of the vehicle and find the front threaded insert located in between the first pair of holes along the pinch weld. **See Figure 1**

Select the Driver/left side Front Mounting Bracket. Attach the Bracket to the threaded insert using (1) 8mm Hex Bolt, (1) 8mm Lock Washer and (1) 8mm Flat Washer. **See Figure 2** Do not fully tighten hardware at this time.

Figure 1

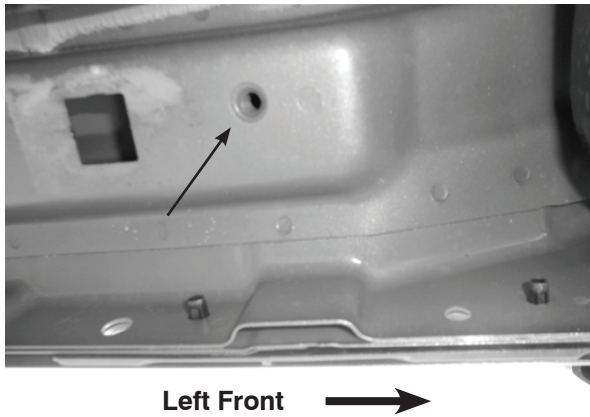
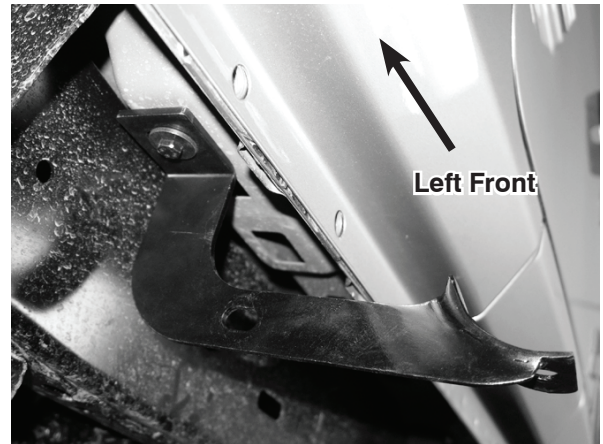

Figure 2



- 3 Select the Driver/left side Front Support Bracket. Align the Bracket to the back of the pinch weld and to the rear side of the Front Mounting Bracket. Attach the Support Bracket to the pinch weld using (2) 6mm Hex Bolts, (4) 6 mm Flat Washers and (2) 6mm Nylon Lock Nuts. **NOTE:** Insert bolts from the outside of the pinch weld and through the Bracket. Use (1) 10mm Hex Bolt, (2) 10mm Flat Washers and (1) 10mm Nylon Lock Nut to secure the Support Bracket to the Mounting Bracket. **See Figures 3 and 4.** Do not fully tighten hardware at this time.

Figure 3

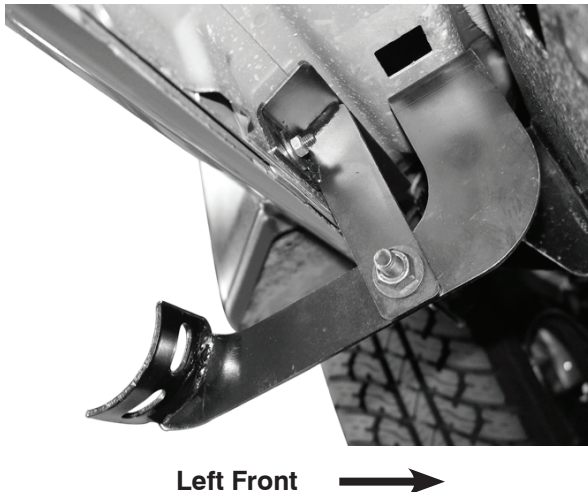
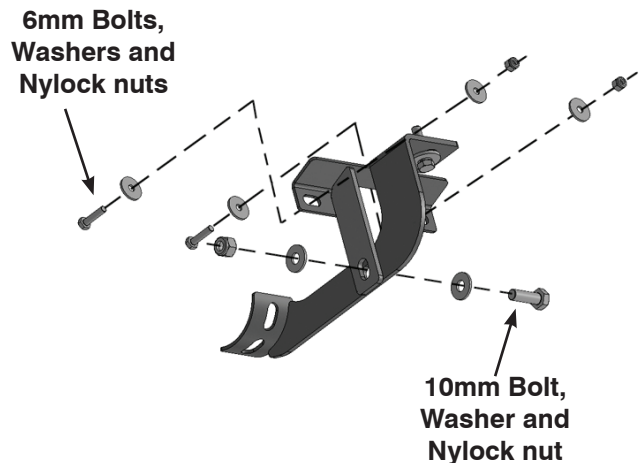

Figure 4



4

Move along the body panel to the center mounting location and locate the threaded insert and pair of holes on the pinch weld. **See Figure 5.** Repeat Step 3 to install the Center Bracket. **See Figure 6.** **NOTE:** The Center and Rear Mounting Brackets look similar but each one is unique. Notice the bottom corner trim on the Center Mounting Bracket in the illustration.

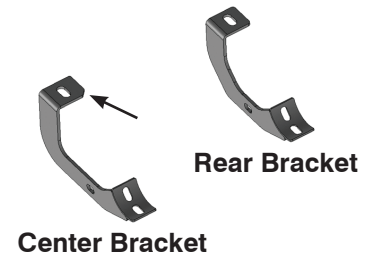

Figure 5

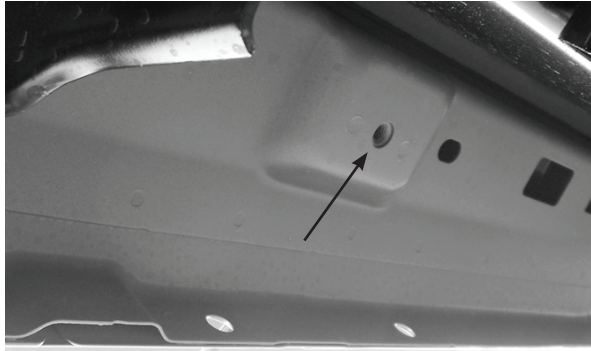
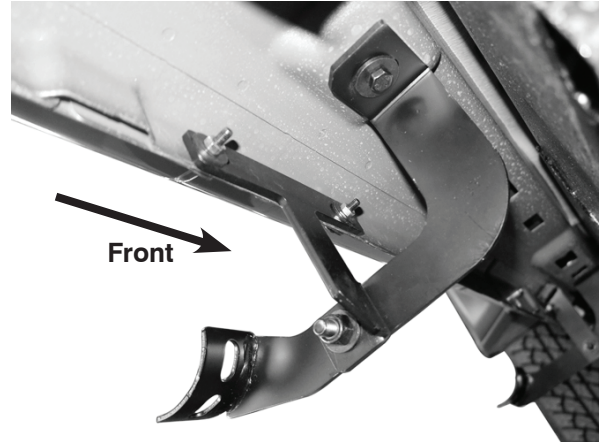

Figure 6



5

Move to the rear mounting location and locate the threaded insert and pair of holes on the pinch weld. **See Figure 7.** Repeat Step 3 to install the Rear Bracket. **See Figure 8.**

NOTE: The Center and Rear Mounting Brackets look similar but each one is unique. Notice the rounded corners on the Rear Mounting Bracket.

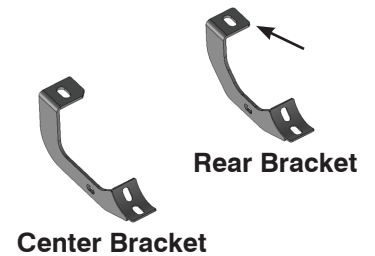

Figure 7

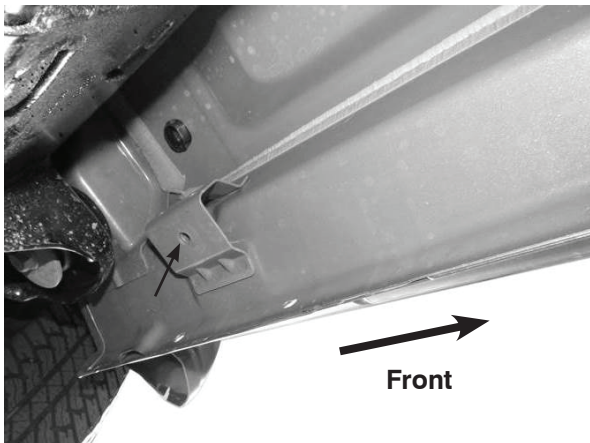
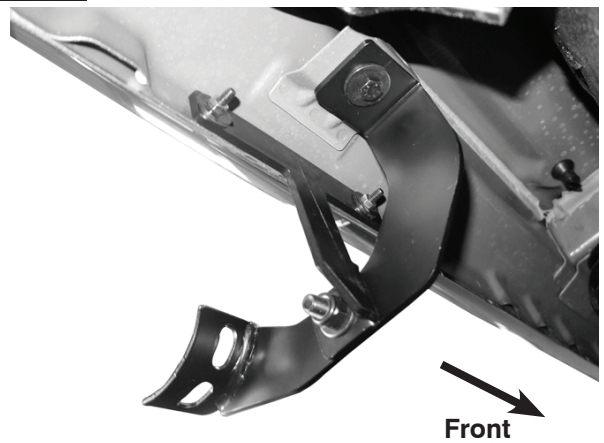

Figure 8



6

Select the Driver/left Sidebar. Carefully position the Sidebar onto the (3) Mounting Brackets. **IMPORTANT:** Do not slide or rotate the Side bar on the Brackets or damage to the finish on the Side bar may result. Attach the Side bar to the Mounting Brackets with (6) 8mm x 25mm Combination Hex Bolts. **See Figure 9.** Do not tighten hardware. **NOTE:** Mounting cradles on Brackets should be inline and pointing toward the rear of the vehicle for proper installation. Snug all hardware but do not tighten.

Figure 9



8mm Combo Bolts

7

Level and adjust side bar. Tighten all hardware.



8

Repeat all steps for right side.

Care and Cleaning

- Rampage products are built to last; any detergent you use to wash your vehicle is sufficient to clean the bumper. Do not use any harsh abrasive detergents. Periodically check and lubricate moving parts.

Congratulations!

You have purchased one of the many quality Rampage branded products offered by Lund International. We take the utmost pride in our products and want you to enjoy years of satisfaction from your investment. We have made every effort to ensure that your product is top quality in terms of fit, durability, finish and ease of installation.



The material that your product is made from can be recycled. Please also consider recycling the packaging that your product came in.



800-328-2409 • Visit us at Rampageproducts.com
© 2018 Lund Motion Products, Inc. All rights reserved.
Rampage Products™ is a trademark of Lund Motion Products, Inc.



Instructions d'installation

18-19 Jeep
Wrangler JL
Unlimited 4 Dr
All Sub-Models

IS-8854_RevA



3 "étapes de tube"

Pour une installation correcte et un ajustement optimal, veuillez lire toutes les instructions AVANT de commencer.

Pour obtenir une assistance technique ou pour obtenir des pièces manquantes, veuillez appeler le service à la clientèle au 800-328-2409 .

Informations de sécurité importantes



- ATTENTION - Avant de conduire, assurez-vous que les marches sont correctement fixées au véhicule.
- Vérifiez régulièrement tous les composants pour vérifier qu'ils sont bien serrés.

Avant l'installation

- Retirez le contenu et vérifiez que toutes les pièces sont présentes.

Contenu

REMARQUE: Le produit réel peut différer de l'illustration.



Avant droite



Support avant droit



Centre droit

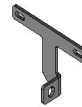

Support central et arrière droit (2)



Arrière droite



Avant gauche



Support avant gauche



Centre gauche



Support central et arrière gauche (2)



Left Rear



Étape du tube gauche



Étape du tube droit

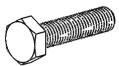

10mm x 30mm
Boulon (6)



Rondelle plate
10mm (12)



Écrou Nylock
10mm (6)

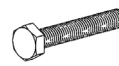

8mm x 35mm
Boulon (6)



8mm Rondelle De
Verrouillage (6)



Rondelle plate 8mm
Boulon (6)



8 mm Combo
Bolt
Boulon (12)



6mm x 25mm
Boulon (12)



6mm plat
Laveuse (24)



6mm Nylock
Écrou (12)

Outils nécessaires



Clé à douille



Jeu de douilles

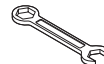

Jeu de clés



Lunettes de
protection

Installation

1

Retirez toutes les marches d'usine ou de rechange ou les garde-fous présents sur le véhicule.

2

Commencez l'installation vers l'avant du côté conducteur du véhicule et trouvez l'insert fileté avant situé entre la première paire de trous le long de la soudure pincée. **Voir la figure 1**

Sélectionnez le support de montage avant côté conducteur / gauche. Fixez le support à la pièce fileté à l'aide de (1) vis à tête hexagonale de 8 mm, (1) rondelle de blocage de 8 mm et (1) rondelle plate de 8 mm. **Voir Figure 2** Ne pas serrer complètement le matériel à ce stade.

Figure 1

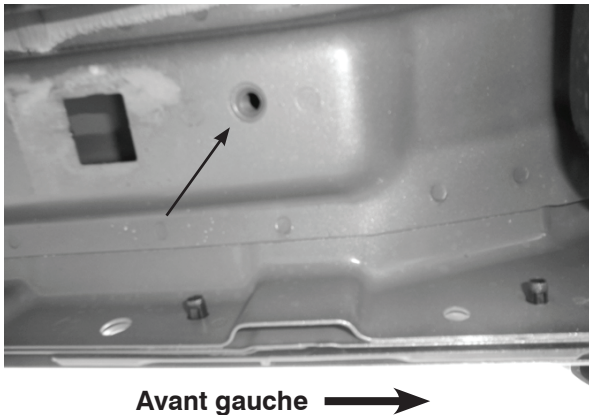

Figure 2



3

Sélectionnez le support de support avant côté conducteur / gauche. Alignez le support à l'arrière de la soudure pincée et à l'arrière du support de montage avant. Fixez le support à la soudure à l'aide de (2) boulons hexagonaux de 6 mm, (4) rondelles plates de 6 mm et (2) écrous en nylon de 6 mm. **REMARQUE:** Insérez les boulons à l'extérieur de la soudure par pincement et à travers le support. Utilisez 1 boulon hexagonal de 10 mm, 2 rondelles plates de 10 mm et 1 contre-écrou en nylon de 10 mm pour fixer le support au support de montage. **Voir les figures 3 et 4.** Ne pas serrer complètement le matériel pour le moment.

Figure 3

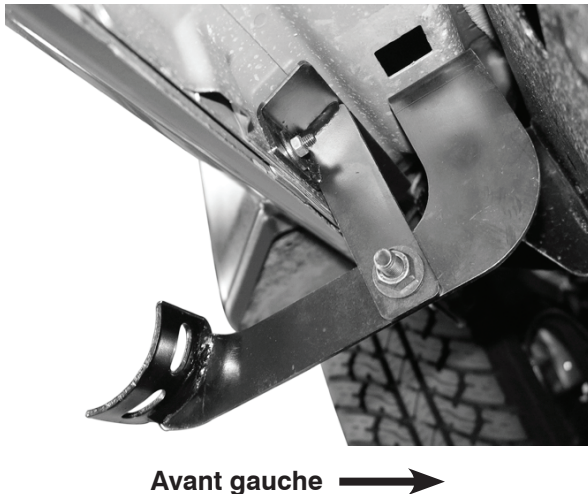
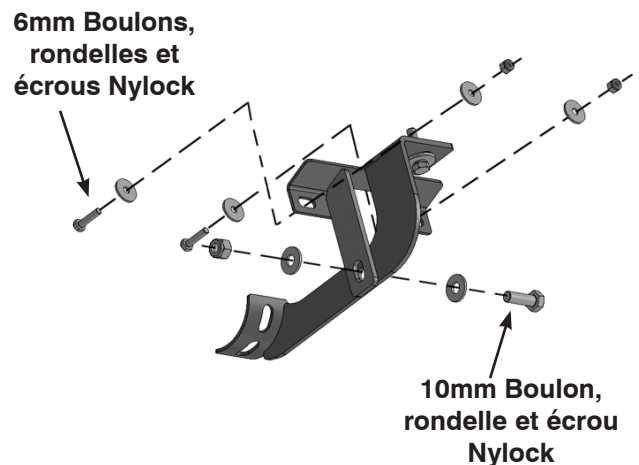

Figure 4



4

Déplacez le long du panneau de carrosserie vers l'emplacement de montage central et repérez l'insert fileté et la paire de trous sur la soudure à pincement. **Voir la figure 5.** Répétez l'étape 3 pour installer le support central. **Voir la figure 6.** **REMARQUE:** Les supports de montage central et arrière ont un aspect similaire, mais chacun est unique. Notez la garniture du coin inférieur du support de montage central dans l'illustration.

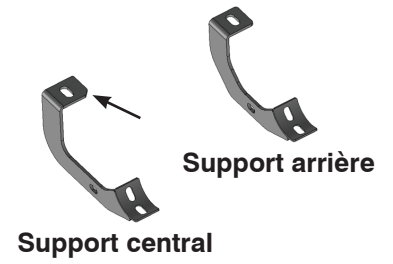
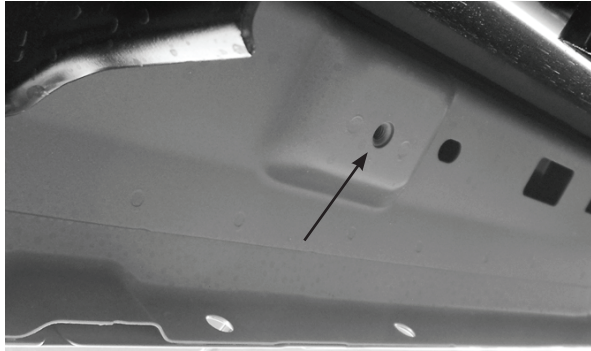
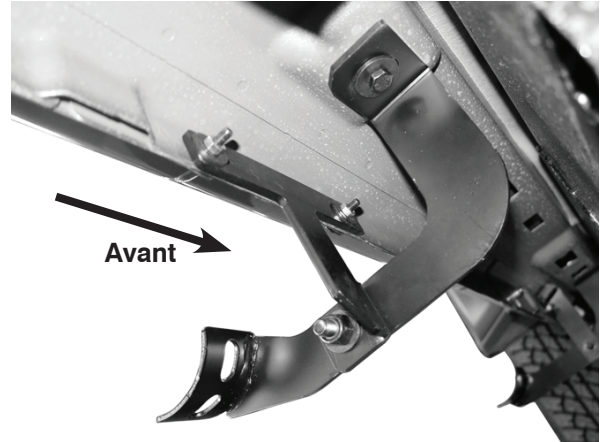

Figure 5



Avant gauche →

Figure 6



Avant

5

Déplacer vers l'emplacement de montage arrière et localiser l'insert fileté et la paire de trous sur la soudure pincée. **Voir la figure 7.** Répétez l'étape 3 pour installer le support arrière. **Voir la figure 8.**

REMARQUE: Les supports de montage central et arrière se ressemblent, mais chacun est unique. Notez les coins arrondis sur le support de fixation arrière.

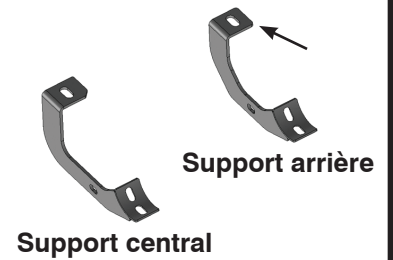
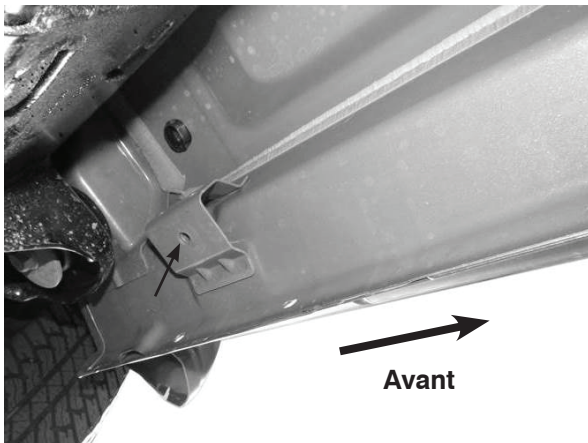
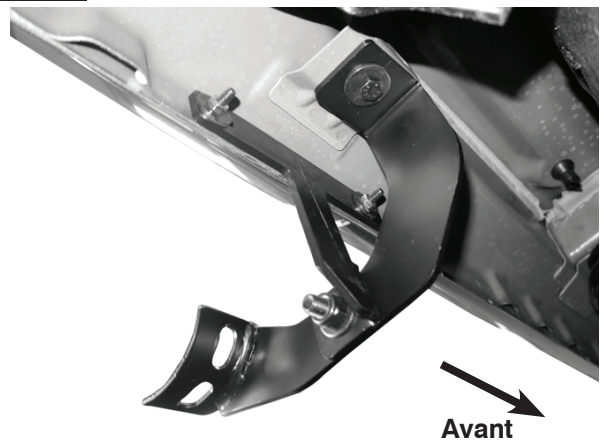

Figure 7



Avant

Figure 8



Avant

6

Sélectionnez le pilote / barre latérale gauche. Positionnez soigneusement la barre latérale sur les (3) supports de montage. **IMPORTANT:** ne faites pas glisser ou ne faites pas pivoter la barre latérale des supports ou vous risquez d'endommager la finition de la barre latérale. Fixez la barre latérale aux supports de montage avec (6) boulons hexagonaux combinés de 8 mm x 25 mm. **Voir la figure 9.** Ne pas serrer le matériel. **REMARQUE:** Les supports de montage sur les supports doivent être alignés et orientés vers l'arrière du véhicule pour une installation correcte. Serrez tout le matériel mais ne serrez pas.

Figure 9

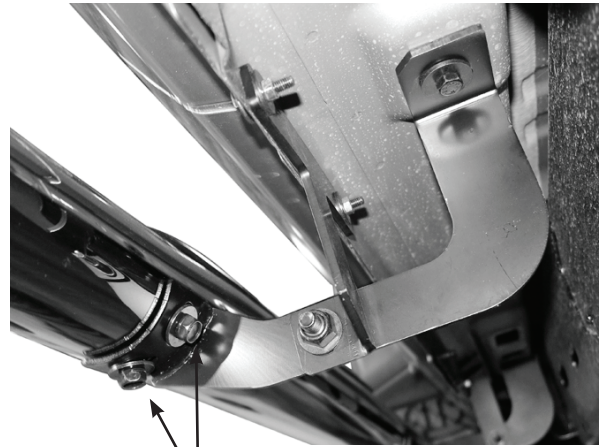

Combo Boulon 8mm

7

Niveler et ajuster la barre latérale. Serrez tout le matériel.

8

Répétez toutes les étapes pour le côté droit.



Soins et nettoyage

- Les produits de rampe sont conçus pour durer; tout détergent que vous utilisez pour laver votre véhicule est suffisant pour nettoyer le pare-chocs. N'utilisez pas de détergents abrasifs puissants. Contrôler et lubrifier périodiquement les pièces en mouvement.

Félicitations!

Vous avez acheté l'un des nombreux produits de qualité Rampage proposés par Lund International. Nous tirons une grande fierté de nos produits et souhaitons que vous profitiez de nombreuses années de votre investissement. Nous nous sommes efforcés de garantir la qualité supérieure de votre produit en termes d'ajustement, de durabilité, de finition et de facilité d'installation.



Le matériau à partir duquel votre produit est fabriqué peut être recyclé. Veuillez également envisager de recycler l'emballage dans lequel votre produit est entré.



800-328-2409 • Rendez-vous sur Rampageproducts.com

© 2018 Lund Motion Products, Inc. Tous droits réservés.

Rampage Products™ est une marque commerciale de Lund Motion Products, Inc.

RAMPAGE
PRODUCTS

LUND
INTERNATIONAL

Instrucciones de instalación

18-19 Jeep
Wrangler JL
Unlimited 4 Dr
All Sub-Models

IS-8854_RevA



3 "pasos de tubo"

Para una instalación adecuada y el mejor ajuste posible, lea todas las instrucciones ANTES de comenzar.
Para asistencia técnica o para obtener piezas faltantes, llame a Atención al Cliente al 1-800-328-2409 .

Información de Seguridad Importante



- PRECAUCIÓN: antes de conducir, asegúrese de que los pasos estén correctamente asegurados al vehículo.
- Verifique periódicamente que todos los componentes estén apretados.

Antes de la instalación

- Eliminar contenido y verificar que todas las piezas estén presentes.

Contenido

NOTA: El producto real puede variar de la ilustración.



Frente derecho



Soporte delantero
derecho

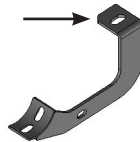

Centro derecho

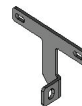

Centro derecho
y soporte trasero
(2)



Trasera derecha



Frente izquierdo



Soporte delantero
izquierdo



Centro izquierdo



Centro izquierdo
y soporte trasero
(2)



Izquierda trasera



Paso de tubo
izquierdo



Paso del tubo
derecho

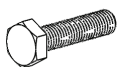

10 mm x 30 mm
Perno (6)



Arandela plana
de 10 mm (12)



Tuerca de 10
mm Nylock (6)

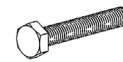

8 mm x 35 mm
Perno (6)



Arandela de
seguridad de 8 mm
(6)



Arandela plana
de 8 mm Perno
(6)



Perno combinado
de 8 mm Perno
(12)



6 mm x 25 mm
Perno (12)



Piso de 6 mm
Lavadora (24)



6 mm Nylock
Nuez (12)

Herramientas necesarias



Llave de
tubo



Juego de Socket

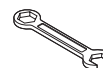

Juego de
llaves



Lentes de
seguridad

Instalación

- 1 Elimine los pasos de fábrica o de posventa o los rieles de roca presentes en el vehículo.
- 2 Comience la instalación hacia la parte delantera del lado del conductor del vehículo y descubra que el inserto roscado delantero se encuentra entre el primer par de orificios a lo largo de la soldadura de presión. **Ver la Figura 1**

Seleccione el Soporte de Montaje Frontal del Controlador / lado izquierdo. Fije el soporte al inserto roscado usando (1) perno hexagonal de 8 mm, (1) arandela de seguridad de 8 mm y (1) arandela plana de 8 mm. **Ver Figura 2** No apriete completamente el hardware en este momento.

Figura 1



Figura 2



- 3 Seleccione el Soporte del Soporte Frontal del Controlador / lado izquierdo. Alinee el soporte con la parte posterior de la soldadura de presión y con el lado posterior del soporte de montaje frontal. Fije el soporte de soporte a la soldadura por presión utilizando (2) pernos hexagonales de 6 mm, (4) arandelas planas de 6 mm y (2) tuercas de seguridad de nylon de 6 mm. **NOTA:** Inserte los pernos desde el exterior de la soldadura pellizcada y a través del soporte. Utilice (1) perno hexagonal de 10 mm, (2) arandelas planas de 10 mm y (1) tuerca de seguridad de nylon de 10 mm para asegurar el soporte al soporte de montaje. **Vea las Figuras 3 y 4.** No apriete completamente el hardware en este momento.

Figura 3

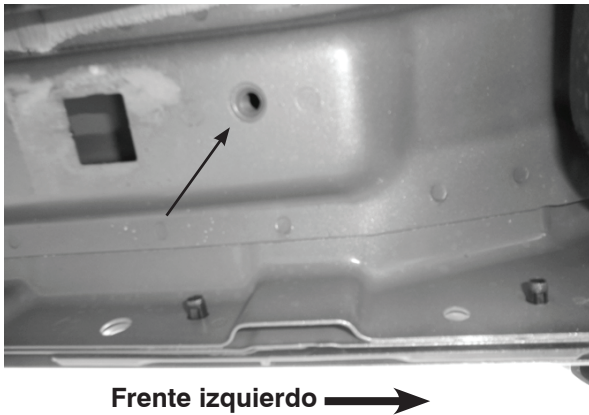

Figura 4



4

Desplácese a lo largo del panel de la carrocería hasta la ubicación de montaje central y ubique el inserto roscado y el par de orificios en la soldadura pellizcada. Consulte la **Figura 5**. Repita el Paso 3 para instalar el soporte central. **Vea la Figura 6**. **NOTA:** Los soportes de montaje central y posterior se ven similares, pero cada uno es único. Observe el borde de esquina inferior en el soporte de montaje central en la ilustración.

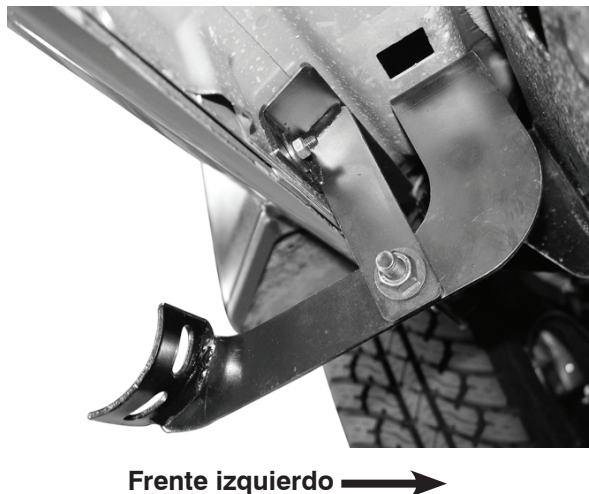
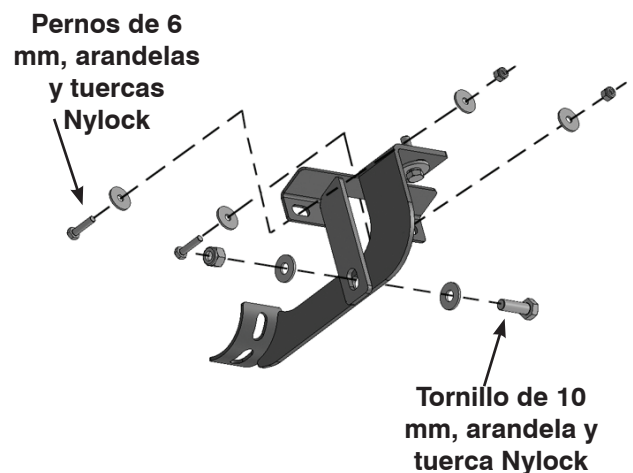

Figura 5



Frente izquierdo →

Figura 6

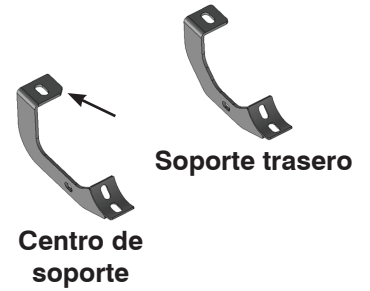
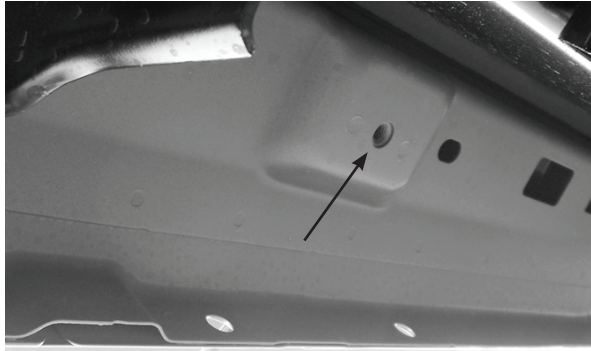
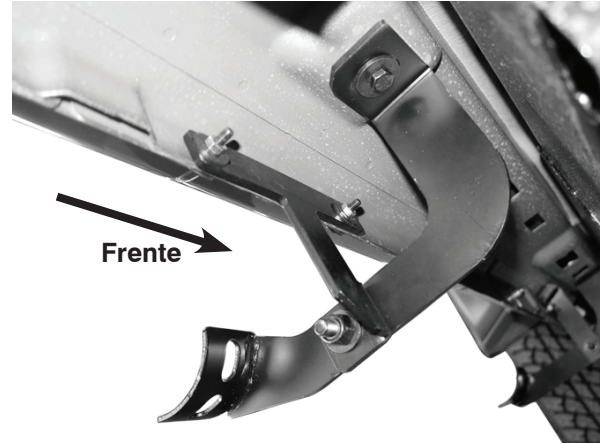

5

Vaya a la ubicación de montaje posterior y ubique el inserto roscado y el par de orificios en la soldadura de presión. **Vea la Figura 7**. Repita el Paso 3 para instalar el Soporte trasero. Ver la **Figura 8**.

NOTA: Los soportes de montaje central y posterior se ven similares, pero cada uno es único. Observe las esquinas redondeadas en el soporte de montaje trasero.



Figura 7



Frente

Figura 8

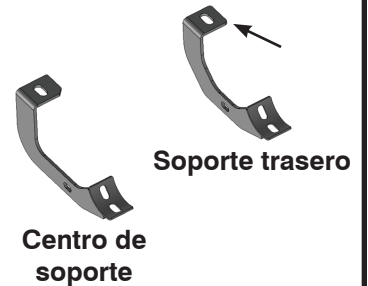
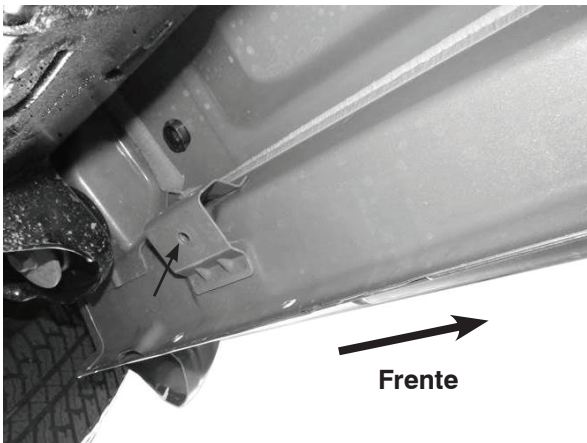
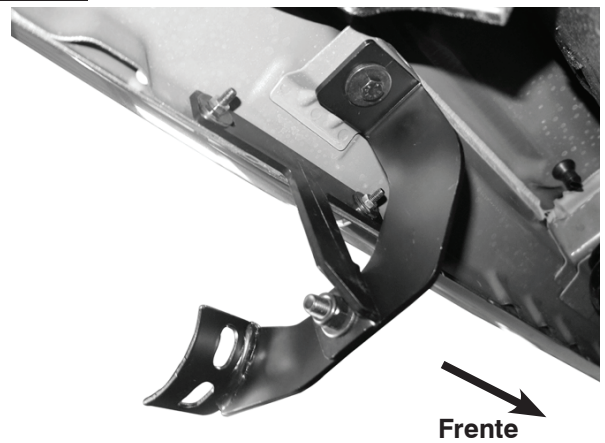

Frente

6

Seleccione el controlador / barra lateral izquierda. Coloque con cuidado la barra lateral en los (3) soportes de montaje. **IMPORTANTE:** No deslice ni gire la barra lateral en los soportes, ya que podría dañar el acabado de la barra lateral. Fije la barra lateral a los soportes de montaje con (6) pernos hexagonales combinados de 8 mm x 25 mm. **Vea la Figura 9.** No apriete el hardware.

NOTA: las cunas de montaje en los soportes deben estar en línea y apuntando hacia la parte trasera del vehículo para una instalación adecuada. Ajuste todo el hardware pero no apriete.

Figura 9



Pernos combinados de 8 mm

7

Nivela y ajusta la barra lateral. Aprieta todo el hardware.

8

Repita todos los pasos para el lado derecho.



Cuidado y Limpieza

- Los productos Rampage están diseñados para durar; cualquier detergente que use para lavar su vehículo es suficiente para limpiar el parachoques. No use detergentes abrasivos fuertes. Controle y lubrique periódicamente las piezas móviles.

¡Felicidades

Usted ha comprado uno de los muchos productos de calidad Rampage ofrecidos por Lund International. Nos enorgullecemos de nuestros productos y queremos que disfrute años de satisfacción de su inversión. Hemos hecho todos los esfuerzos posibles para garantizar que su producto sea de alta calidad en términos de ajuste, durabilidad, acabado y facilidad de instalación.



El material del que está hecho su producto puede reciclarse. Considere también reciclar el embalaje en el que entró su producto.



800-328-2409 • Visítanos en Rampageproducts.com
© 2018 Lund Motion Products, Inc. Todos los derechos reservados.
Rampage Products™ es una marca registrada de Lund Motion Products, Inc.

