



B&W Trailer Hitches

1216 Hawaii Road / PO Box 186

Humboldt, KS 66748

P:800.248.6465

F:620.869.9031

NOTE: *We recommend reading instructions before beginning the installation.*

WARNING: *The tow vehicle's towing capacities should Under NO Circumstances be exceeded.*

Turnoverball® Gooseneck Hitch Installation Instructions

Model 1500R

Call or Email us for Installation Support

hitches@turnoverball.com www.bwtrailerhitches.com

Flatbed Kit

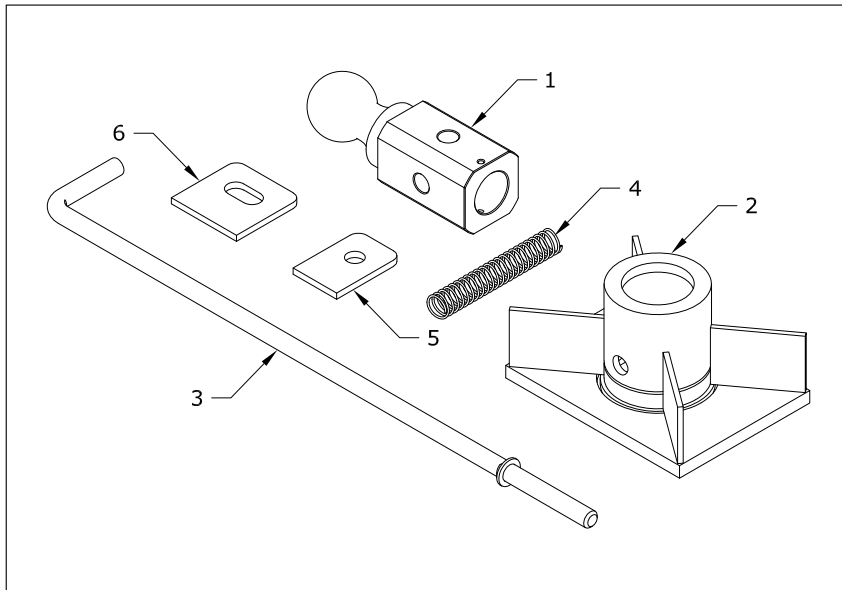

Kit Parts

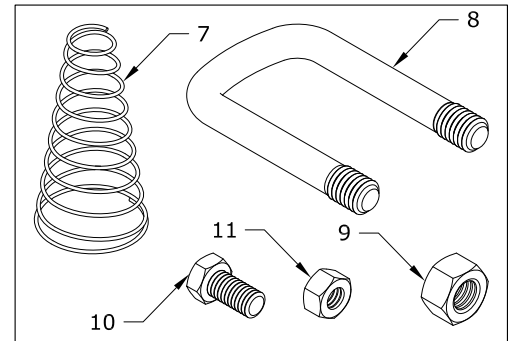

Safety Chain Kit Parts

PARTS LIST

ID	DESCRIPTION	QUANTITY
1	- 2 5/16" BALL	1
2	- FLAT BED SOCKET ASSEMBLY	1
3	- LATCH PIN HANDLE	1
4	- SPRING	1
5	- HANDLE GUIDE W/ ROUND HOLE	1
6	- HANDLE GUIDE W/ SLOTTED HOLE	1

SAFETY CHAIN KIT, PARTS LIST

ID	DESCRIPTION	QUANTITY
7	- CONICAL SPRING	4
8	- 1/2" U-BOLT	2
9	- 1/2" CENTER LOCK NUT	4
10	- 3/8" CAP SCREW (NOT NEEDED)	1
11	- 3/8" CENTER LOCK NUT (NOT NEEDED)	1

BEFORE INSTALLING

WARNING

Most trucks have FUEL LINES and/or BRAKE LINES and/or ELECTRICAL WIRES located along the frame rails where B&W Turnoverball™ hitches install. Carefully examine the location of fuel lines, brake lines and electrical wires BEFORE INSTALLATION. Be certain you will not damage fuel lines, brake lines or electrical wires when positioning hitch components, drilling holes, tightening fasteners, and lifting and lowering the truck bed. The fuel tank vent, located on top of the gas tank, can be easily damaged during the installation of the hitch components. Care must be taken when positioning the front crossmember and center section components.

Warning

On Short bed trucks, BEFORE INSTALLING THIS HITCH, check for adequate turning clearance between the front of all of your trailers and the truck cab.

Warning

DO NOT invert the ball in the socket when carrying heavy loads on 2 wheel drive trucks. The ball may hit the top of the differential. Remove the ball from the socket before loading. A plug for the socket is available from B & W.

INSTALLATION INSTRUCTIONS

Note: The flat bed hitch kit has been designed to be used with 1/8" thick floor plate. Because of the close tolerances between the socket and hitch ball base, welding the hitch socket should be avoided. If you weld the floor to the top of the hitch socket, reduce the heat of the weld to prevent heat distortion of the socket.

STEP ONE

Locate the center of the receiver socket forward of the axle 2-6 inches. Make sure from the center of the socket to the rear corner of the bed is 72" or less. This will allow for proper truck to trailer turning clearance on most trailers. When the proper location is determined and marked, cut or drill a 4" hole.

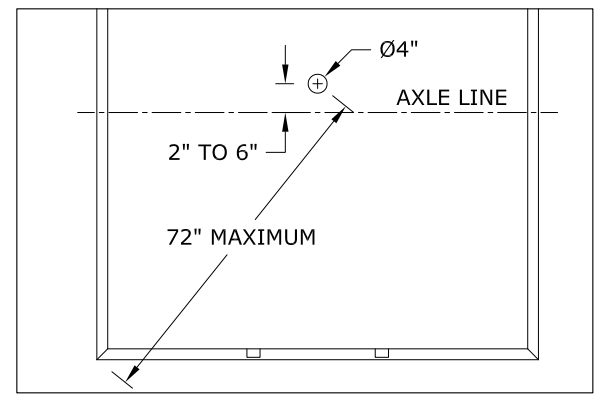

Top View of Truck Bed

STEP TWO

Fit the socket in the four inch hole (see 2.1), insuring the 1/2" plate is flat against the floor of the bed. Weld the two sides of the 1/2" plate that do not have the holes for the latch pin handle (see 2.2)

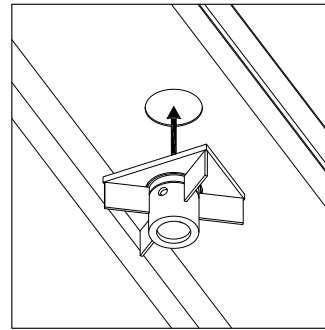

2.1 Install Receiver.

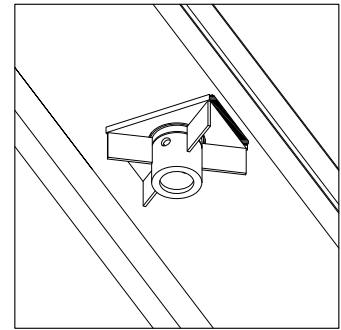

2.2 Weld Sides.

STEP THREE

Use 1/4" T x 4" W x 16" L mild steel strap (or equivalent) to brace from the truck bed C4 x 5.4 "C" channel cross members, in front of the socket assembly (see 3.1), to the truck bed cross member rear of the socket assembly (1/4" x 4" x 16" strap not included). The 4" strap will need to have a 2-1/2" round relief hole cut on the driver side for the handle to travel through (see 3.2). When welding the strap, weld the fins on the socket to the strap, stitch weld the strap to the floor of the bed, and weld to the truck bed cross members. Consult B&W's engineering department for an installation that deviates from our recommended installation practices or any other installation questions.

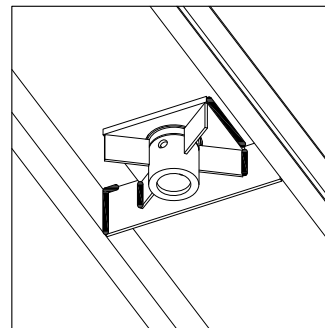

3.1 First Brace.

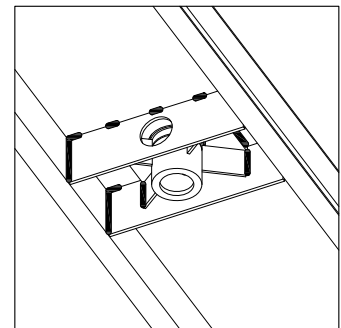

3.2 Second Brace.

STEP FOUR

Place the spring on the latch pin handle then put the handle through the handle guide w/ the round hole. Place the handle in the hole in the receiver socket. Compress the spring between the washer on the latch pin handle and the round pin guide then measure 6" from the socket to the round pin guide, and weld to the floor of the bed. Place the slotted pin guide on the handle, measure from the socket 16", and weld to the floor of the bed (see 4.1).

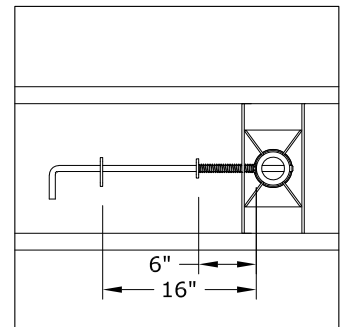

4.1 Install Latch.

STEP FIVE

When installing the safety chain loops place them slightly ahead of the socket assembly and a minimum of 6 1/2" from the center of the socket assembly, to each side. (Placing them in the truck bed cross member in front of the socket assembly would be ideal.) Two 9/16" holes on 2" centers will be needed on each side of the socket assembly to install the safety chain loops (see 5.1). Drop the safety chain loops through each pair of holes. Place a spring and lock nut on each of the four legs. Tighten the lock nuts until they are flush with the bottom of the u-bolt (see 5.2).

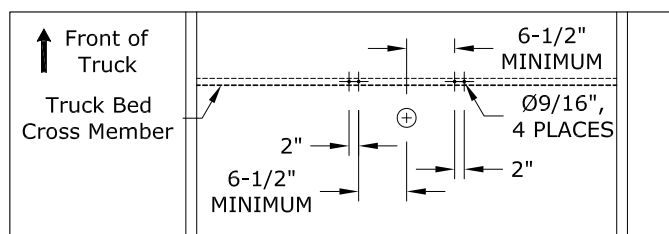

5.1 Install Safety Chain Loops.

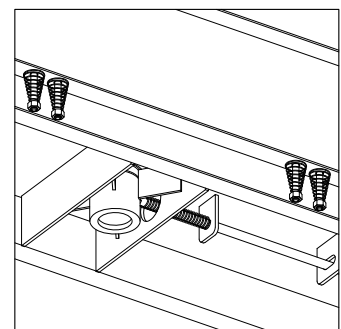

5.2 Install Safety Chain Hardware.