

IMPORTANT: READ BEFORE INSTALLATION

STEP 1: REMOVE FACTORY FENDER FLARES, FENDER TRIM AND MUD FLAPS IF INSTALLED.

STEP 2: VERIFY FIT

- (A) FLARES SHOULD BE HELD TO VEHICLE TO VERIFY CORRECT TYPE AND FIT BEFORE BEGINNING INSTALLATION.

(IF INSTALLING CAMO SERIES FLARES, OR PAINTING IS NOT DESIRED SKIP TO STEP 4)

STEP 3: PAINTING PAINTED FLARES CANNOT BE RETURNED. TEST FIT BEFORE PAINTING

(IF PAINTING IS DESIRED IT IS RECOMMENDED TO BE DONE PRIOR TO INSTALLATION.)

- (A) SAND (OPTIONAL) BEFORE APPLICATION OF PAINT
(B) CLEAN OUTER SURFACE WITH A WAX & GREASE REMOVER *(DO NOT USE LACQUER THINNER OR ENAMEL REDUCER AS A DEGREASER)*
(C) WIPE OUTER SURFACE WITH A TACK CLOTH.
(D) PAINT FLARES USING A HIGH QUALITY LACQUER, ENAMEL, OR POLYURETHANE AUTOMOTIVE PAINT.
(APPLICATION OF A PRIMER COAT PRIOR TO PAINTING IS OPTIONAL)
(E) IF PAINTING EDGE TRIM (NOT RECOMMENDED) USE A FLEX ADDITIVE.

STEP 4: EDGE TRIM INSTALLATION

- (A) PEEL THREE INCHES OF RED BACKING AWAY FROM EDGE TRIM ADHESIVE AND AFFIX TO OUTER EDGE OF FLARE AT ONE END.
(B) PRESS EDGE TRIM INTO PLACE ALONG EDGE OF FLARE IN ONE-FOOT INCREMENTS, PULLING RED BACKING FREE AS YOU CONTINUE TO WORK YOUR WAY AROUND THE FLARE. (Fig 1)

(STEP 5 APPLIES ONLY TO "Ruff Riderz" STYLE FLARES, FOR ALL OTHERS, SKIP TO STEP 6)

STEP 5: BOLT INSTALLATION

WARNING: DO NOT OVER TIGHTEN OR USE LOCTITE® ON THE BOLTS AS THIS WILL CAUSE PERMANENT DAMAGE TO THE FLARES. BOLTS ARE DECORATIVE ONLY AND FASTEN ONLY TO THE FLARES. DO NOT ATTEMPT TO USE THE BOLTS TO FASTEN THE FLARES TO THE VEHICLE.

- (A) DRILL A 5/16" HOLE IN THROUGH THE DIVITS IN EACH OF THE POCKETS
(B) PLACE A 5/16" BUTTON HEAD SCREW WITH A WASHER INTO EACH OF THE HOLES AND ATTACH TO THE FLARE USING A NUT PLACED ON THE INSIDE. (fig 2)

STEP 6: FRONT FLARE INSTALLATION

- (A) REMOVE THE 3 FACTORY SCREWS HOLDING THE PLASTIC INNER FENDER WELL TO THE FENDER AND SET ASIDE.
(B) HOLD THE FLARE IN PLACE ON THE VEHICLE AND LINE UP THE HOLES IN THE FLARE WITH THE FACTORY HOLES FROM THE 3 REMOVED SCREWS, RE-USE THE SCREWS TO ATTACH THE FLARE TO THE VEHICLE.

STEP 7: REAR FLARE INSTALLATION

- (A) REMOVE THE 2 FACTORY SCREWS HOLDING THE PLASTIC INNER FENDER WELL AND SET THEM ASIDE.
(B) HOLD THE FLARE IN PLACE ON THE VEHICLE AND INSERT THE 2 SCREW LOCKS THROUGH THE FRONT HOLES OF THE FLARE INTO THE EXISTING FACTORY HOLES.
(C) REINSTALL THE FACTORY SCREWS THROUGH THE 2 HOLES AT THE REAR SIDE OF THE FLARE
(D) USE 3 SELF TAPPING SCREWS IN THE REMAINING HOLES IN UPPER SIDE OF THE FLARE. (Fig 3)

KIT CONTAINS:

4 SCREW LOCKS
6 SELF TAPPING SCREWS

TOOLS REQUIRED:

#2 PHILLIPS BIT
DRILL*
5/16" DRILL BIT*
3/16" HEX WRENCH*
1/2" WRENCH*
UTILITY KNIFE

* Applies only to the "Ruff Ridez" style flares for attaching hardware.

(fig 1)

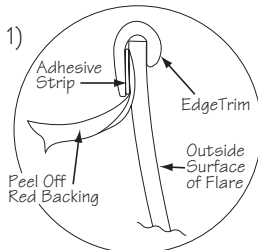

(fig 2)

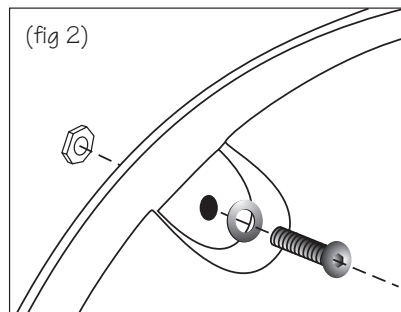

Vehicle Front

(fig 3)

