



SUPERLIFT®

S U S P E N S I O N

Superlift Replacement Extended Length Rubber and Bulletproof Brake Hoses for 1999-2004 Ford F-250 / F-350 4WD INSTALLATION INSTRUCTIONS

INTRODUCTION

Installation requires a professional mechanic. Prior to beginning, inspect the vehicles steering, driveline, and brake systems, paying close attention to the suspension link arms and bushings, anti-sway bars and bushings, tie rod ends, pitman arm, ball joints and wheel bearings. Also check the steering sector-to-frame and all suspension-to-frame attaching points for stress cracks. The overall vehicle must be in excellent working condition; repair or replace all worn parts.

Read instructions several times before starting. Be sure you have all needed parts and know where they install. Read each step completely as you go.

NOTES:

- Any work pertaining to your vehicle’s brake system must be performed by a technician certified on your particular vehicle.
- Prior to installation, carefully compare the new hose to the original since the vehicle manufacturer may have made model / design changes without our knowledge.
- A foot-pound torque reading is given in parenthesis () after each appropriate fastener.
- Do not fabricate any components to gain additional suspension height.
- Prior to attaching components, be sure all mating surfaces are free of grit, grease, undercoating, etc.
- Have a factory service manual on hand to reference procedures and specifications that are unique to this vehicle.
- Use the check-off box “☐” found at each step to help you keep your place. Two “☐☐” denotes that one check-off box is for the driver side and one is for the passenger side. Unless otherwise noted, always start with the driver side.

PARTS LIST ... The part number is stamped into each part or printed on an adhesive label. Identify each part and place the appropriate mounting hardware with it.

PART NO	DESCRIPTION (Qty.- if more than one)	NEW ATTACHING HARDWARE (Qty.)
55-10-9680	front brake line drop bracket, passenger side	(2) 7/16” x 1-1/4” bolt (2) 7/16” SAE washer (2) 7/16” nyloc nut
55-11-9680	front brake line drop bracket, driver side	(2) 7/16” x 1-1/4” bolt (2) 7/16” SAE washer

		(2) 7/16" nyloc nut
01-91500.....	front brake hose, driver side	(2) 7/16" crush washer (1) 3/8" plug
02-91500.....	front brake hose,..... passenger side	(2) 7/16" crush washer

INSTALLATION PROCEDURE

1) PREPARE VEHICLE...

WARNING: Brake fluid contains Polyglycol Ethers and Polyglycols. Avoid contact with eyes, and wash hands thoroughly after handling. If brake fluid contacts eyes, flush eyes with water for fifteen minutes. Get medical attention if irritation persists. If taken internally, induce vomiting and get medical attention immediately.

- Inspect the brake system and repair / replace components as necessary.
- During the entire procedure, thoroughly clean and inspect all mating surfaces.

2) FRONT BRAKE HOSES AND VACUUM HOSE EXTENSIONS...

NOTE: Perform the following steps one side at a time.

- On each side, unbolt the brake line tab (where the metal brake line connects to the rubber hose) from the frame.

- [DIAGRAM 3] Attach the supplied brake hose relocation brackets (#55-10-9680 passenger side and #55-11-9680 driver side) to the existing holes in the frame using the supplied 7/16" x 1-1/4" bolts, washers, and nyloc nuts. Tighten (37).

- Loosen and remove the banjo bolt securing the brake hose to the caliper. Have a catch pan ready to catch any spilled fluid. Then use a line wrench to disconnect the metal brake line from the rubber hose. Place a cap on the metal line to minimize fluid loss.

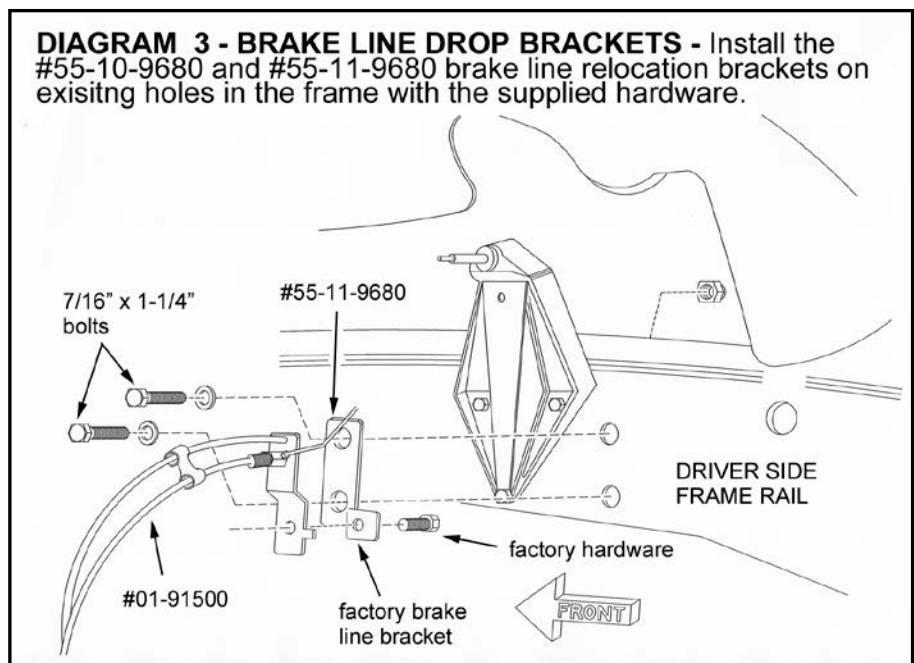

- Attach the supplied brake hoses (#01-91500 driver side and #02-91500 passenger side) to the metal line and tighten to the specifications found in the factory service manual. Use a line wrench to avoid damaging the fitting.

NOTE: Some models have two metal brake lines that attach to the driver side brake hose. If two lines are present, simply connect them to the supplied #01-91500 hose and tighten to factory specifications. If only one metal line is present, use the supplied 3/8" plug to cap off one of the two inlets built in to the #01-91500 hose.

- Attach the other end of the hose to the caliper using the factory banjo bolt. Use the new copper crush washers supplied with the hoses. Tighten to factory specifications.
- Carefully reform the metal line to reach the factory brake line tab in its new location and secure using the factory hardware. Tighten to factory specifications.

3) FINAL PROCEDURES...

- With the suspension supporting vehicle weight, and the tires / wheels installed, cycle the steering lock-to-lock and check for adequate hose length and clearance. Now raise the vehicle and check length / clearance with the suspension "hanging" at full extension travel.

NOTE: On some disc brake applications, it may be necessary to slightly bend the hoses' metal inner tube, where it comes off of the caliper block, in order to gain clearance. Likewise, a slight amount of "tweaking" may be needed at the hoses' upper mounting tab as well.

NOTE: The need to "fine tune" hose routing primarily depends on tire size and wheel offset.

WARNING: It is critical that the hoses do not make contact with any other component(s) at anytime during turning, and during the suspension's entire compression / extension travel cycles, or chafing will occur. Chafing will ultimately lead to hose failure which, in turn, can lead to loss of vehicle control.

- Bleed air from the system as instructed by the factory service manual. Avoid getting brake fluid on painted surfaces.

IMPORTANT PRODUCT USE INFORMATION

As a general rule, the taller a vehicle is, the easier it will roll over. Offset, as much as possible, what is lost in roll over resistance by increasing tire track width. In other words, go "wide" as you go "tall". Many sportsmen remove their mud tires after winter / hunting season and install ones more appropriate for street driving; always use as wide a tire and wheel combination as possible to enhance vehicle stability.

We strongly recommend, because of roll over possibility, that the vehicle be equipped with a functional roll bar and cage system. Seat belts and shoulder harnesses should be worn at all times. Avoid situations where a side rollover may occur.

Generally, braking performances and capabilities are decreased when significantly larger / heavier tires and wheels are used. Take this into consideration while driving.

Do not add, alter, or fabricate any factory or aftermarket parts to increase vehicle height over the intended height of the Superlift product purchased. Mixing component brands is not recommended.

Most states have some type of law limiting vehicle height. The amount of lift allowed, and how the lift may be achieved, varies greatly. Several states offer exemptions for farm or commercially registered vehicles. It is the owner's responsibility to check state and local laws to ensure that their vehicle will be in compliance.

Superlift makes no claims regarding lifting devices and excludes any and all implied claims. Superlift will not be responsible for any altered product or any improper installation or use of our products.

We will be happy to answer any questions concerning the design, function, and correct use of our products.

IMPORTANT MAINTENANCE INFORMATION

It is the ultimate buyer's responsibility to have all bolts / nuts checked for tightness after the first 100 miles and then every 1000 miles. The steering, suspension and driveline systems, along with wheel alignment should be inspected by a qualified professional mechanic at least every 3000 miles.

NOTICE TO DEALER AND VEHICLE OWNER

Any vehicle equipped with a Superlift lifting device must have the enclosed "Warning to Driver" decal installed on the inside of the windshield or on the vehicle's dash, within driver's view. The "Warning to Driver" decal is to act as a constant safety reminder for whoever may be operating the vehicle. The WARRANTY IS VOID unless this decal is in place. **INSTALLING DEALER...** It is your responsibility to install warning decal and forward these installation instructions to the vehicle owner for review of warnings, product use and maintenance information. Replacement warning decals are available free upon request. These instructions are to be kept with the vehicle registration papers and owners manual for the service life of the vehicle.

SUPERLIFT LIMITED LIFETIME WARRANTY

Suspension products bearing the Superlift (LKI Ent.) name are warranted for as long as the original purchaser owns the vehicle that the LKI product was originally installed on. This warranty is non-transferable. Warranty covers only the product, no labor, time loss, or freight incurred. Any product that has been abused, altered, incorrectly installed, or used in competition is not covered. Product finish, spring bushings, Polyurethane products, and normal wear is not covered. The LKI product is subject to replacement or repair. No other warranties are expressed or implied. An authorized Superlift dealer must inspect the part in question and confirm that the "Warning to Driver" decal is properly displayed. A copy of the sales invoice is required for warranty consideration.

SUPERLIFT SUSPENSION SYSTEMS

300 Huey Lenard Loop Rd.
West Monroe, Louisiana 71292
Phone: (318) 397-3000
Sales / Tech: 1-800-551-4955
FAX: (318) 397-3040
www.superlift.com