



Jeep® Wrangler 2007-2018 Trail Armor Flatback Top 2 Door (JK)

STEP 1 – PRIOR TO INSTALLATION

- A)** Bushwacker only approves installing the soft top according to these written instructions with the hardware provided. **WARNING:** Failure to install according to these instructions will invalidate the warranty. This includes, but is not limited to using alternative installation methods, hardware, or materials. For correct installation, temperature of mounting surface of part should be between 70-95°F (21-35°C) prior to installation.
- B) Care & Cleaning:** Bushwacker soft tops are built to last; Washing: The soft top fabric should be washed often using a mild soap, warm water and a soft bristle brush (do not use the brush on the window glass!). You can also use special soft top cleaners. Make sure that after cleaning you rinse with clear water to remove all traces of soap.
- C) Windows:** It is very important that you keep your windows clean! Use a mild soap and water solution to gently clean your windows. **NEVER** wipe your windows clean with a dry cloth! Dust and dirt on a dry cloth can scratch your windows causing “fogging” and permanent damage. When removing your windows, store them in the window storage bag provided.
- D) Pre-Installation requirements**
Remove existing hard or soft top on your Jeep Wrangler. For OEM (original/factory) soft tops, also remove the following parts:
- Windshield header bar
 - Tube frame hardware from roll bar
 - Side door surrounds
 - Rear window, tailgate bar, tailgate clips

Set Part #BWT-15235
Rev-1 04/06/2018

For complete fitment info visit : www.bushwacker.com











TOOLS FOR EASY INSTALLATION:

- Phillips Screwdriver
- Ratchet and Extensions
- Torx Bit T25
- Allen Wrench
- Safety Glasses

LIMITED LIFETIME WARRANTY AGAINST ANY MANUFACTURING DEFECTS

- To claim a warranty, you must provide Proof of Purchase.

Contents:

- | | | | | |
|---|--|---|---|--|
| 1. 
Trailview
Man Deck
1 pcs | 2. 
Tonneau
Cover
1 pcs | 3. 
Back
Window
1 pcs | 4. 
Sport Bar
Cover
2 pcs | 5. 
Hinge Plate
LH
1 pcs |
| 6. 
Hinge Plate RH
1 pcs | 7. 
Retainer Tailgate Plastic
2 pcs | 8. 
Tailgate bar
1 pcs | 9. 
Self Tap Screw
22 pcs | 10. 
Shoulder Bolt
4 pcs |

Contents cont.

11.



Flip top hardware
1 pcs

12.



LH Upright Horizontal
1 pcs

13.



RH Upright Horizontal
1 pcs

14.



LH Vert Upright
1 pcs

15.



RH Vert Upright
1 pcs

16.



LH Upper Corner Plastic
1 pcs

17.



RH Upper Corner Plastic
1 pcs

18.



Tonneau
Support
1 pcs

19.



Front Latch 2 pcs

20.



Door Surround Bracket
Front 2 pcs

21.



Upright Turn Knob
2 pcs

22.



Top Retention Strap
1 pcs

23.



Nut 4 pcs

24.



Door Surround Knob
Long,Med,Short 6 pcs

25.



Door Surround Bracket
Rear 2 pcs

26.



Strap Hardware
(Bolt,Washer,Nut)
1 pcs



NEVER OPEN UP OR CLOSE YOUR SOFT TOP ROOF WHILE DRIVING OR WHILE THE VEHICLE IS MOVING. SERIOUS DAMAGE TO YOUR VEHICLE AND SOFT TOP CAN OCCUR! ALWAYS PULL OFF THE ROAD IN A SAFE AREA, COME TO A COMPLETE STOP AND PUT THE VEHICLE IN PARK BEFORE ATTEMPTING TO FOLD BACK OR RE-SECURE YOUR SOFT TOP.

Installation Procedures:



Important: For a smooth fit and ease of installation, this top should be installed at temperatures above 72 degrees. Below this temperature, the fabric may contract an inch or more making it difficult to install. We highly recommend taking your new TrailView Tonneau Top™ out of the package and letting it sit inside a warm place or in direct sun light for 1-2 hours before you install the top. When warm, this top will install quickly.

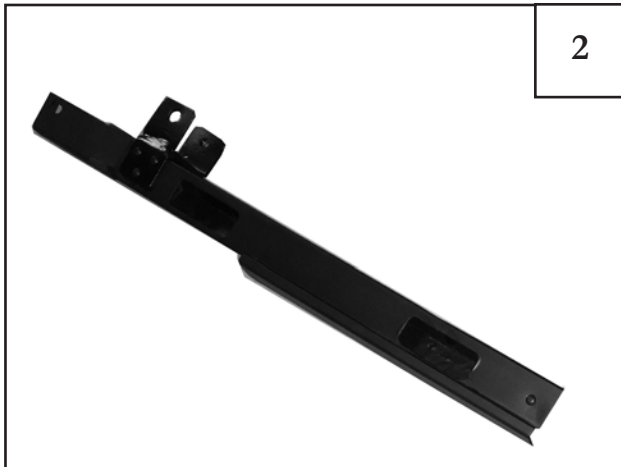

Assemble door surround by inserting the front extrusion bar into the corner upper horizontal part pre-assembly as shown.

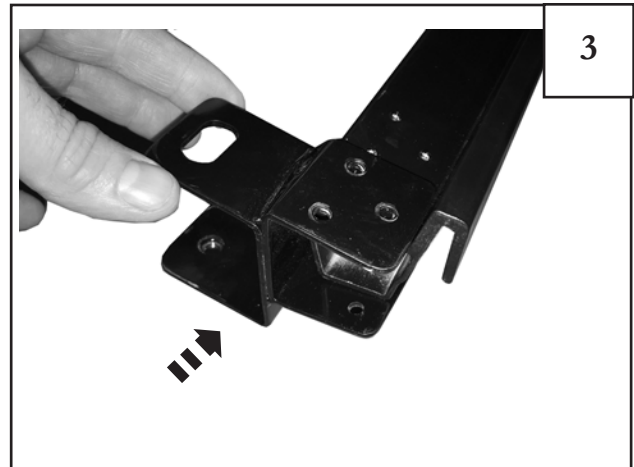

Install rear bracket to rear end of rear extrusion bar by sliding over to line up holes as shown. Do not screw at this time.

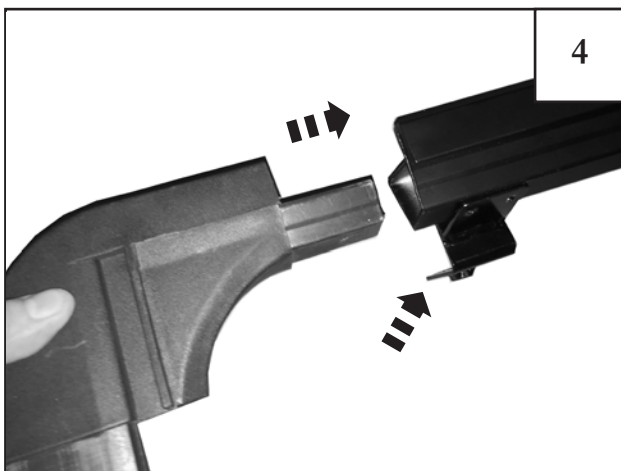

With bracket in place insert the plastic corner into the rear extrusion.

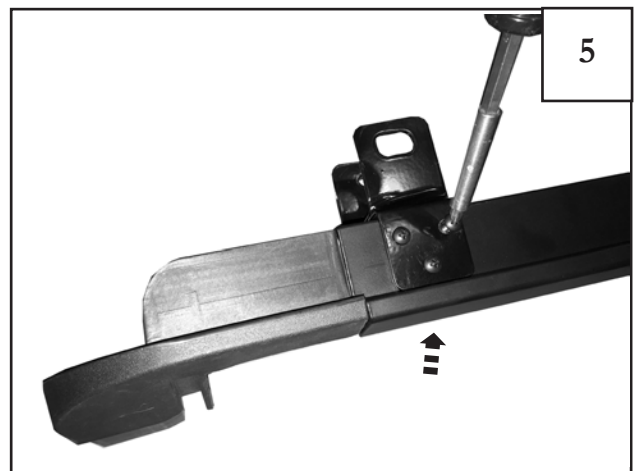

Using a 3 screws tighten into plastic corner part and rear bracket as shown.

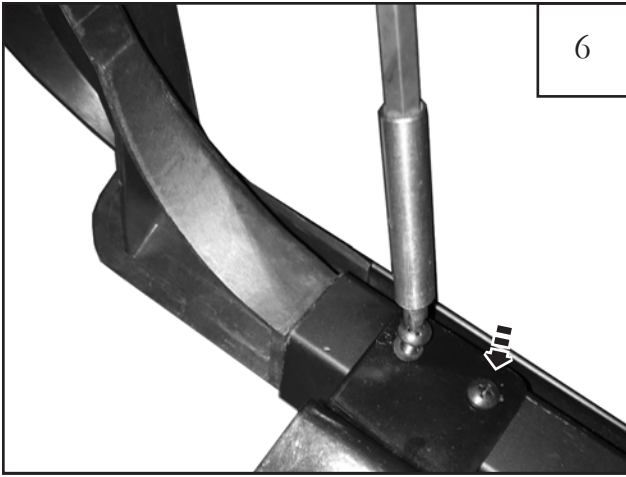

6
Rotate door surround over to access the bottom side. With 2 screws tighten them into plastic corner part as shown.

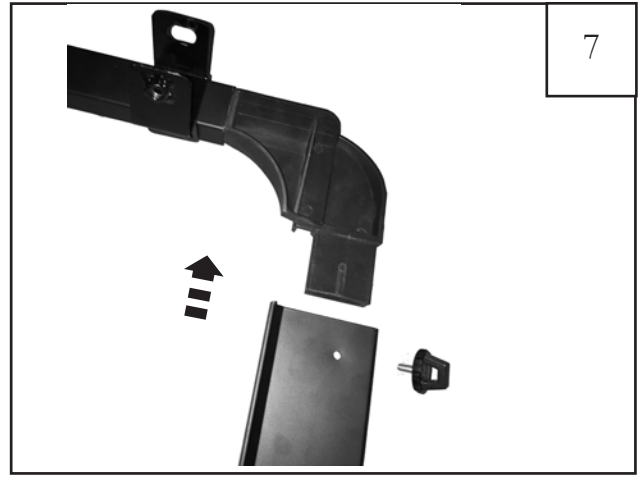

7
Insert the other end of the plastic corner part into the vertical extrusion part and secure with the turn knob screw.



8
Install and secure with the turn knob screw as shown.



9
The door surround assembly is now complete. Repeat these steps (steps 2-9 to assemble the other door surround frame).

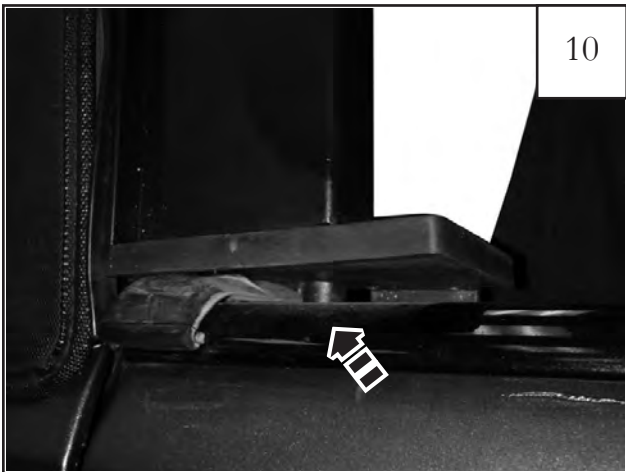

10
Position completed door surround onto the vehicle and fit the bottom base pin into the hole in vehicle tub near the front door latch.



11
Position door surround rear bracket onto the vehicle and fit the bracket over the sport bar.

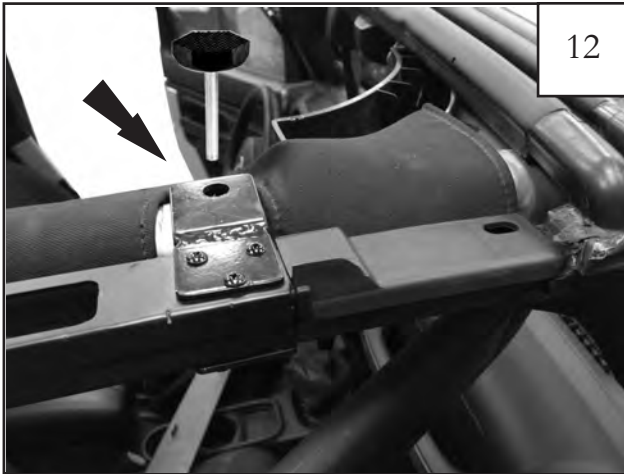

Position our surround front bracket onto the vehicle and fit the bracket over the sport bar sport bar.

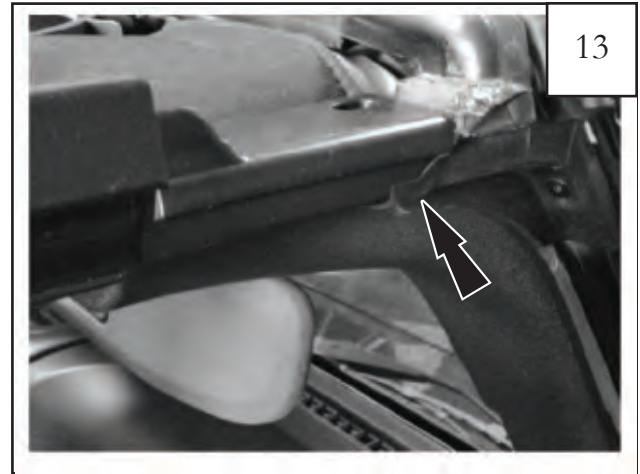

TIP: Make sure the rubber gasket at the top of the windshield is correctly sealed against the front door surround section. See photo for proper fit and check that the factory foam seal is in place.



Place driver side mount plate on top completed door surround onto the vehicle and fit the bracket over the roll bar. Line up front hole to the front bracket door surround. Repeat this step for both sides.



Starting at the front bracket hole insert door surround knob into hole and tighten. Repeat step 14-15 for other side.



Fit top retention strap to door surround mount plate hole located at rear. Locate the unused hole on the back of door surround plate as shown. Note: There is only one strap and it is installed on the driver side.



Put the retention strap in place with the bolt through the grommet as shown. Next, install the 2nd washer and Nylock nut on top of the strap and tighten with 13mm socket wrench and 13mm wrench.



When the top is in the folded back position reach up and hook the retention strap over the bar as shown. **Note: The strap is used to safely secure the soft top in the open position at high speeds.**



Make sure to unhook the retention strap from the bar before folding the top forward again.



Use a Torx T25 bit to remove both the footman loop from the windshield on both the driver's and passenger's side as shown.



Install provided latch as shown and reattach with the Torx T25 bolt from the previous step.

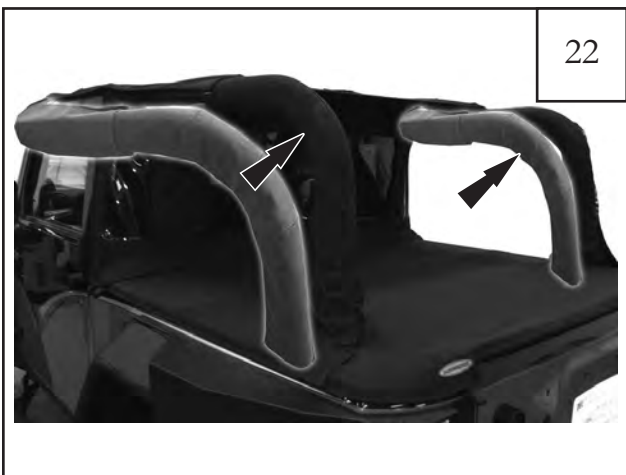

Install sport bar cover wrap onto the sport bar



Wrap around the base of the sport bar as shown.

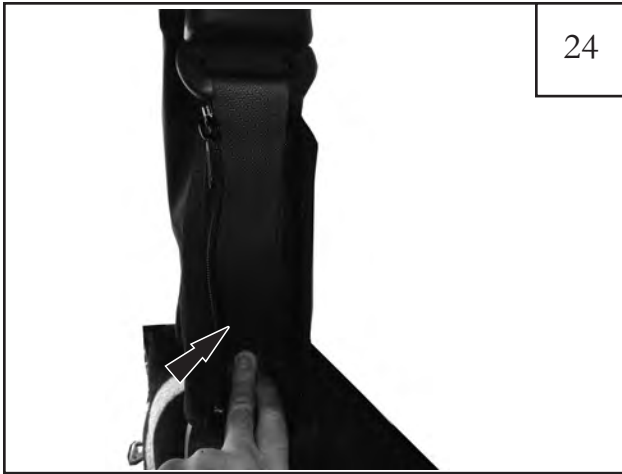

24

Starting at the bottom of sport bar base. Tuck in the seat belt inside the sport bar covers as shown.



25

Locate zippers and connect and start zippers as shown on each side.

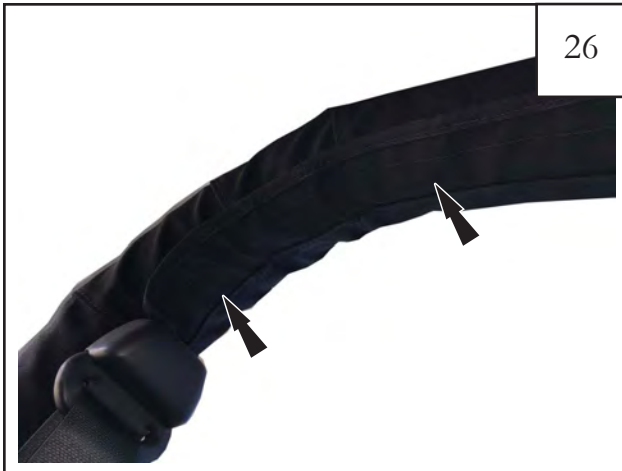

26

Zip upper curved zipper and then connect hook and loop flap closed.



27

Secure hook and loop as shown. Repeat Steps 22-27 for other side.



28

Place the top hardware tubes assembly on top of the main deck fabric then insert into the front pocket. Secure with snaps as shown. **Tip: Place front metal into corner pockets and pull all the way until it fits snug.**

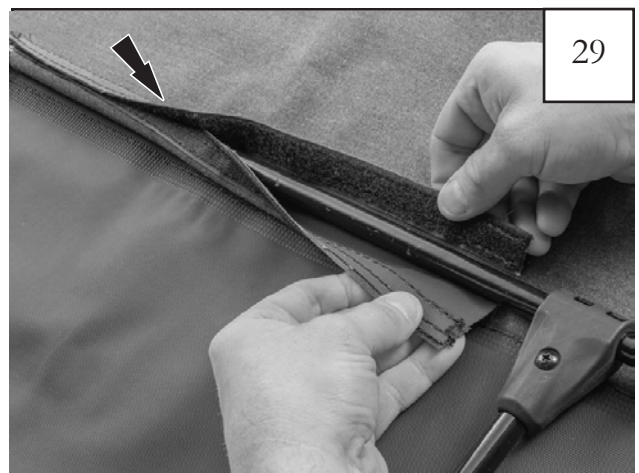

29

Secure the Flip Top tube to the Soft Top main deck by engaging the Hook and Loop flaps as shown on both sides.

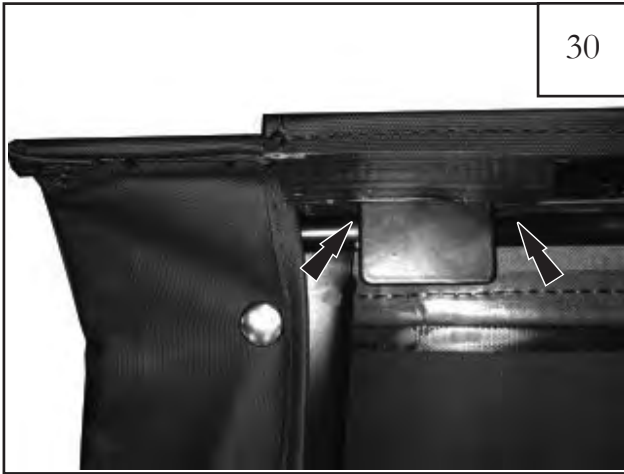

30

Tuck the plastic strip into square metal part as shown for proper fit as shown both sides.



31

TIP: Place the top face down and re-fold, beginning with the rear window portion. It may be helpful to have a second person for this step.

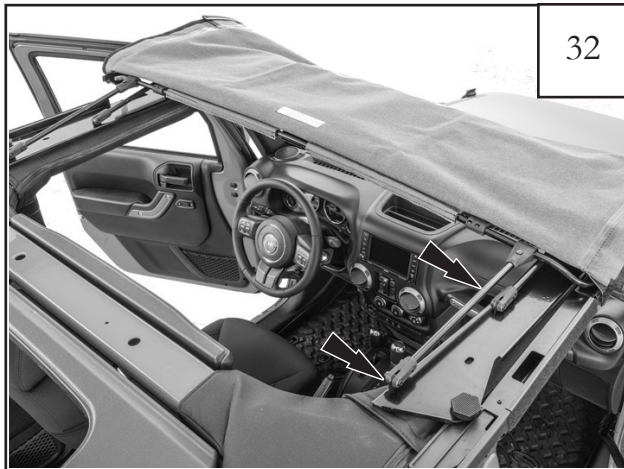

32

Lift the folded soft top and hardware assembly onto the top of the Wrangler sport bar. Place and center toward the front windshield gasket and line up 4 pivot point clamps as shown.



33

Using the supplied 4mm Allen key, install the Shoulder Bolts from the outside of each soft top header assembly knuckle and tighten each bolt with a lock nut 4 places. The lock nut will fit into plastic.



34

Pull the flip top header assembly tightly against the windshield seal and hook to catch. For proper tight adjustment of the latches, unscrew each front screw hook latch where the latching hook just reaches the header assembly.



35

Closed and secure the front latches as shown on both sides at this time.



36

Un-Fold the soft top over the sport bar frame working toward the rear of vehicle.



37

Wrap the two straps attached to the middle section of fabric around the rear-middle of the sound bar.



38

Insert plastic hooks into the holes on the underside of the sound bar. Tighten the strap until snug then hook and loop. **TIP: If soft top appear loose on top these can be pulled tighter for tight soft top.**



39

Attach the main deck belt rail plastic into the upper door surround sides from front to back. Start at the windshield header.

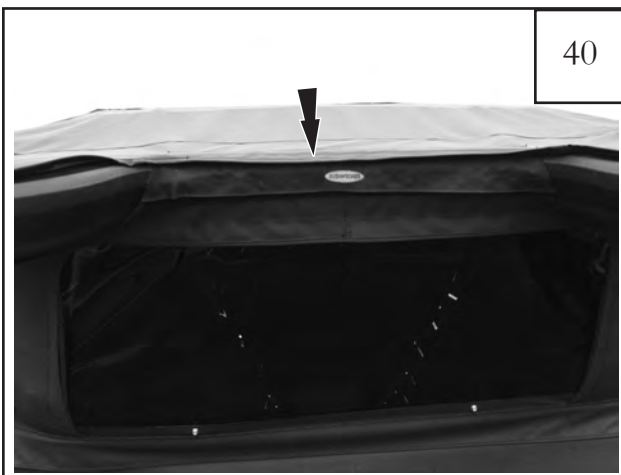

40

Install rear window . Attach middle upper zipper from the back window to the main cover.

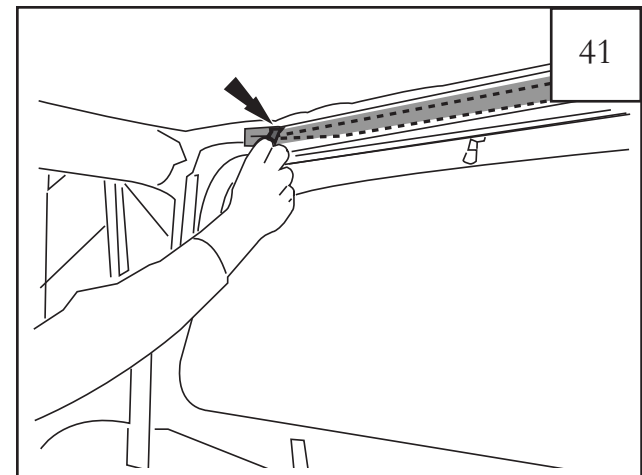

41

From the inside of the wrangler attach zipper from the upper back window to the main cover fabric by zipping into place. **Note: Access from the inside to start zipper.**



42

Locate the side corner straps at the upper corners of the back window. From inside the wrangler.



43

Connect and tighten the straps around the sport bar, thread the end through the buckle as shown. **Note: Straps should be snug and can be tighten later to properly mount.**



44

From the outside of the wrangler start zipper from the upper door surround to the main cover fabric by zipping into place. **Note: Access from the outside to start zipper.**

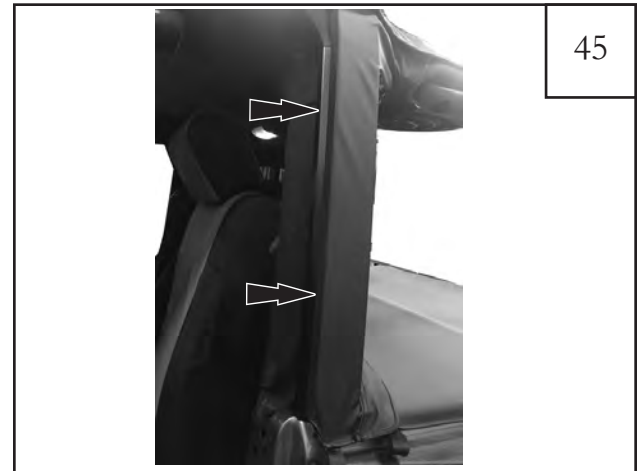

45

Tuck rear window sides into the door surround sides by sliding the plastic backing into the door surround as shown. Repeat on other side. **Tip: Start at the top and work your way down. Then tuck in small tab at bottom.**



46

Connect and close hook and loop flap



47

Flap in closed position shown.



48

Locate the side plastic and tuck it into speaker housing and sport bar next to edge of speaker.
Note: The upper corners of the back window on both driver and passenger side.



49

Locate the side plastic and tuck it into the belt rail of tub. **Note: The bottom corners of the back window on both driver and passenger side.**

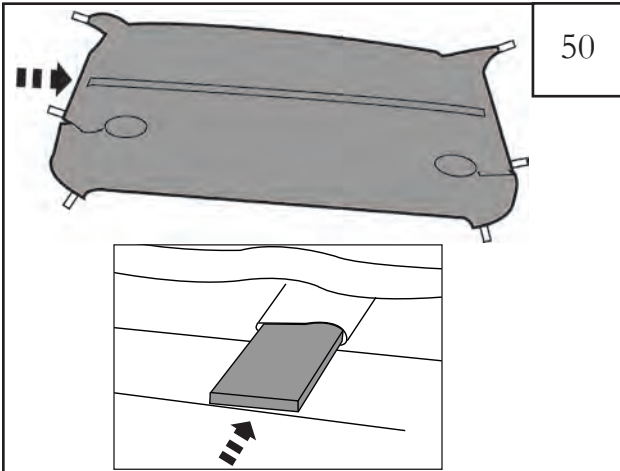

50

Lay the Tonneau cover upside down to access support bow sleeve. Insert Tonneau cover support bow into pocket sleeve.



51

Lay the Tonneau cover into the back of the tub and place cover around the base of the sport bar as shown. **Note: Do not tighten collars at this time allow to remain loose.**



52

Start on the passenger side at the bottom of the back window and zip the tonneau cover to the back window.

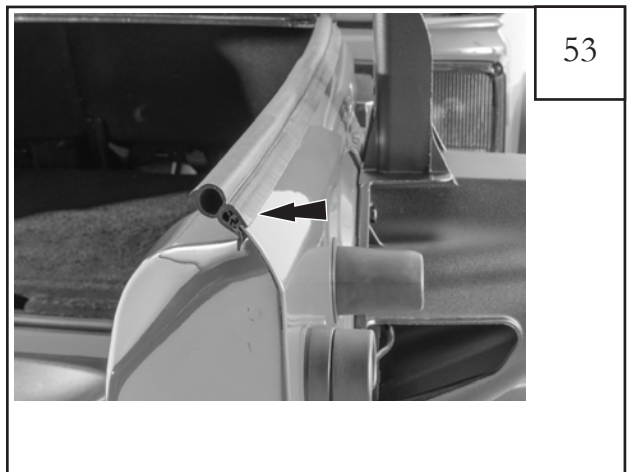

53

Install rubber seal to top edge of the end gate. Seal tail points towards the front of the vehicle.

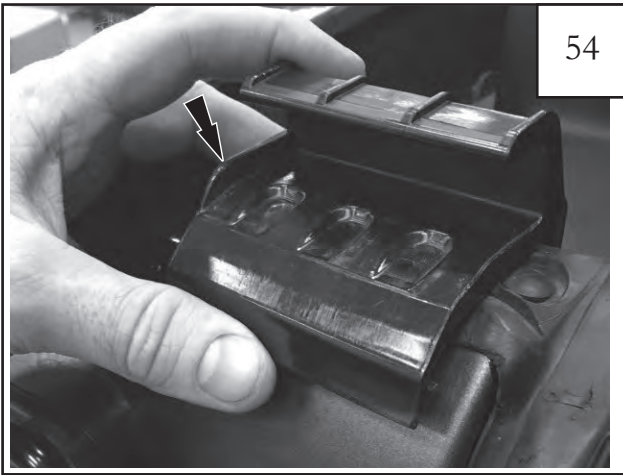

54

Install the Plastic retainer Tab goes to outside of vehicle. Tailgate Bar holder by hooking the back edge of retainer inside tub.

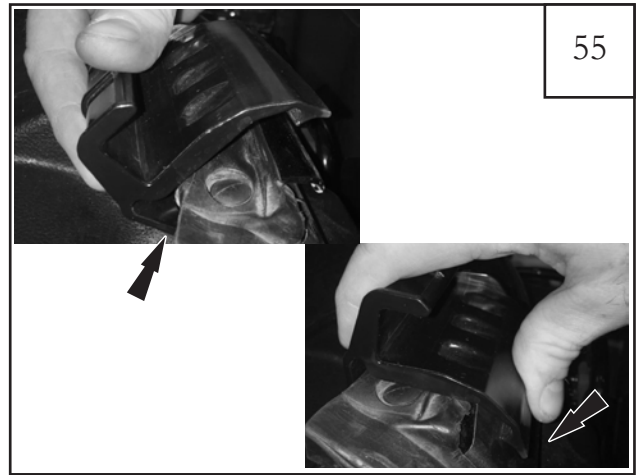

55

Close the clamp with downward pressure front edge over the belt rail sheet metal. The clamp will snap and lock onto the underside of the tube edge.

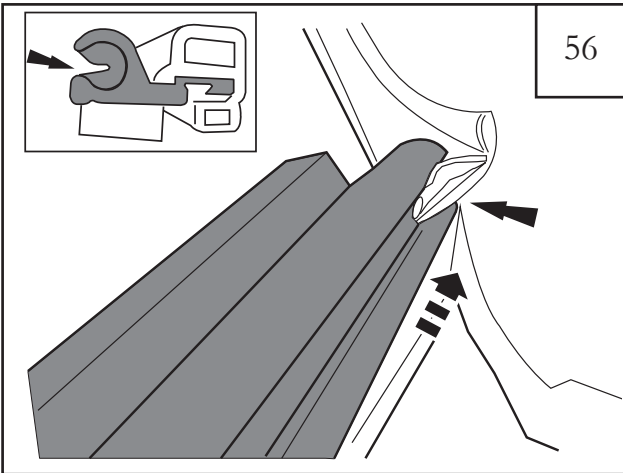

56

Slide the tailgate bar onto the rear of the tonneau cover, using the built-in C-channel to guide it over the flap and small tube.

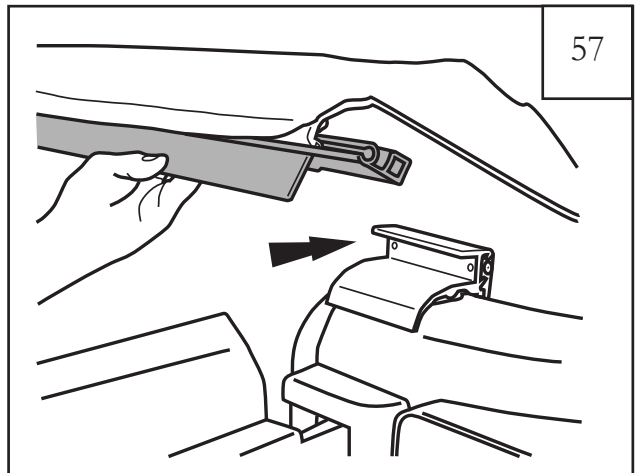

57

Insert the Tailgate Bar into the brackets by pushing the bar against the brackets and rotating it towards your body.



58

Locate the side plastic and tuck it into the belt rail of tub. **Note: on both driver and passenger side.**



59

Locate the side plastic and tuck it into the belt rail of corner. **Note: on both driver and passenger side.**

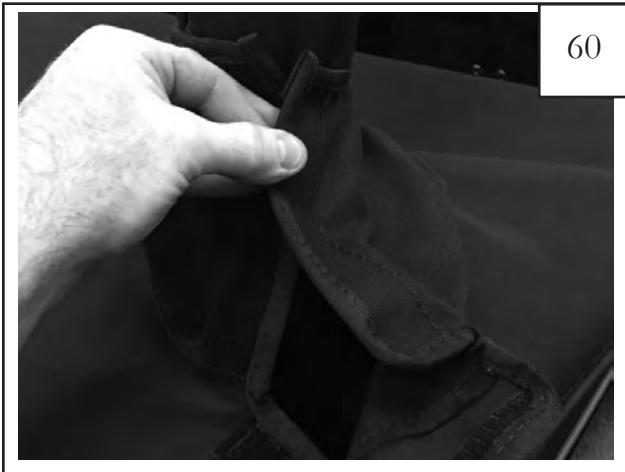

60

Connect the hook and loop collar flaps around the sport bar base. Be sure the sport bar cover is inside here then place the seat belt in open edge.



61

The installation of the soft top is now complete. Be sure all hook and loop flaps are closed.



62

The following Steps show the use after installation. With your vehicle completely stopped engaged in park and in safe area, unlatch the two front latches. Undo the hook & loop side strips attached to the upper door surrounds.



63

Grab the Flip Top Center Grab Handle and push up. The frame will pivot towards the back of the vehicle and rest on itself.



64

Once the soft top is open remember to attach retention strap for speed over 55mph [Refer to Step 18].



65

To close, stop the vehicle, pull off the road in a safe area and put the vehicle in park. Remove retention strap and lift the center grab handle and push up. Latch both windshield latches and re-attach the hook & loop fasteners on the door surrounds. Enjoy your **Bushwacker Trail Armor Soft Top™!**



STEP 1 – PRIOR TO INSTALLATION

- A)** Bushwacker only approves installing the soft top according to these written instructions with the hardware provided. **WARNING:** Failure to install according to these instructions will invalidate the warranty. This includes, but is not limited to using alternative installation methods, hardware, or materials. For correct installation, temperature of mounting surface of part should be between 70-95°F (21-35°C) prior to installation.
- B) Care & Cleaning:** Bushwacker soft tops are built to last; Washing: The soft top fabric should be washed often using a mild soap, warm water and a soft bristle brush (do not use the brush on the window glass!). You can also use special soft top cleaners. Make sure that after cleaning you rinse with clear water to remove all traces of soap.
- C) Windows:** It is very important that you keep your windows clean! Use a mild soap and water solution to gently clean your windows. **NEVER** wipe your windows clean with a dry cloth! Dust and dirt on a dry cloth can scratch your windows causing “fogging” and permanent damage. When removing your windows, store them in the window storage bag provided.
- D) Pre-Installation requirements**
Remove existing hard or soft top on your Jeep Wrangler. For OEM (original/factory) soft tops, also remove the following parts:
- Windshield header bar
 - Tube frame hardware from roll bar
 - Side door surrounds
 - Rear window, tailgate bar, tailgate clips

Jeep® Wrangler de 2007-2018 Trail Armor con capota Fastback 2 puertas (JK)

N.º de pieza: BWT-15235
Rev-1 04/06/2018

Para obtener información completa sobre la instalación,
visite: www.bushwacker.com

HERRAMIENTAS PARA UNA FÁCIL INSTALACIÓN:

- Destornillador Phillips
- Trinquete y extensiones
- Broca Torx T25
- Llave Allen
- Gafas de seguridad

GARANTÍA LIMITADA DE POR VIDA POR DEFECTOS DE FABRICACIÓN

- Para reclamar una garantía, debe proporcionar el comprobante de compra.

Contenido:

- | | | | | |
|--|---|---|---|--|
| 1.

Cubierta principal
Trailview
1 pieza | 2.

Cobertor
de caja
1 pieza | 3.

Ventana
trasera
1 pieza | 4.

Cobertor de
barra deportiva
2 piezas | 5.

Placa de
bisagra izq.
1 pieza |
| 6.

Placa de bisagra der.
1 pieza | 7.

Retén plástico de puerta trasera
2 piezas | 8.

Barra de puerta trasera
1 pieza | 9.

Tornillo autorroscante
22 piezas | 10.

Perno de reborde
4 piezas |

Contenido

11.



Componentes de la capota abatible
1 pieza

12.



Barra horizontal recta, izq.
1 pieza

13.



Barra horizontal recta, der., 1 pieza

14.



Barra vertical recta, izq.
1 pieza

15.



Barra vertical recta, der.
1 pieza

16.



Esquina superior de plástico, izq.
1 pieza

17.



Esquina superior de plástico, der.
1 pieza

18.



Soporte de cobertor
1 pieza

19.



Pestillo delantero
2 piezas

20.



Frente del soporte del anillo de la puertat
2 pcs

21.



Perilla de giro vertical
2 pieza

22.



Correa de retención superior
1 pieza

23.



Tuerca, 4 piezas

24.



Perilla para marco de puerta; larga, corta, media; 6 piezas

25.



Puerta trasera soporte trasero
2 pcs

26.



Correa de hardware (Bolt, Washer, Nut)
1 pcs



NO ABRA NI CIERRE LA CAPOTA MIENTRAS CONDUCE O MIENTRAS EL VEHÍCULO ESTÁ EN MOVIMIENTO. ¡SE PUEDEN OCASIONAR DAÑOS GRAVES EN EL VEHÍCULO Y LA CAPOTA! SALGA DE LA CARRETERA SIEMPRE EN UN ÁREA SEGURA. DETENGA EL VEHÍCULO PARA PODER ESTACIONAR ANTES DE INTENTAR REPLEGAR O REASEGURAR LA CAPOTA.

Procedimientos de instalación:

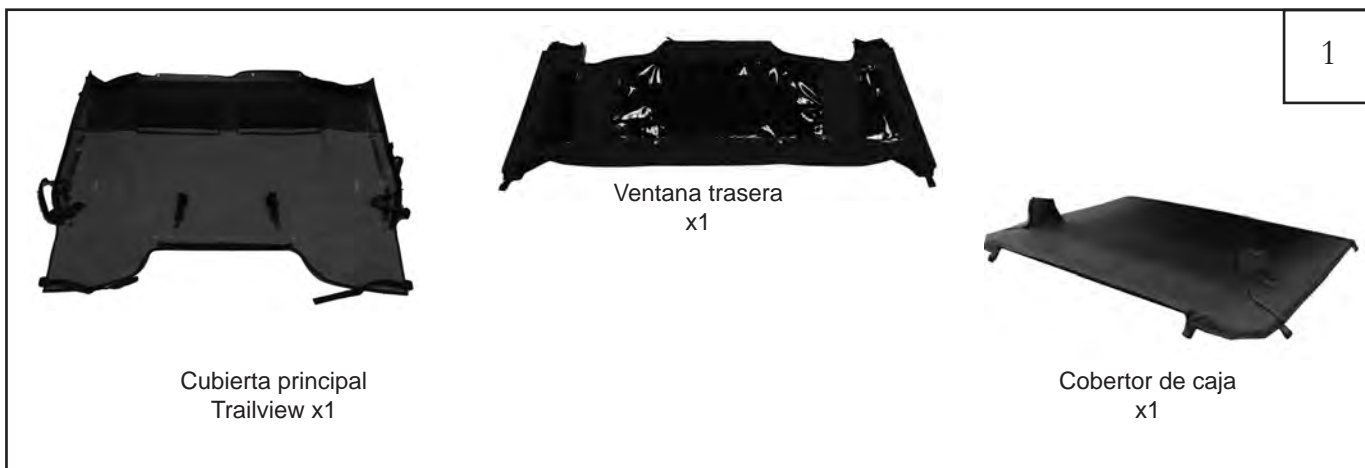

Importante: Para lograr un ajuste adecuado y facilidad de instalación, esta capota debe instalarse a temperaturas superiores a 72 grados. Por debajo de esta temperatura, la tela puede contraerse una pulgada o más, lo que dificulta su instalación. Recomendamos firmemente que saque su nuevo TrailView Tonneau Top™ del paquete y lo deje reposar dentro de un lugar cálido o bajo la luz directa del sol durante 1 a 2 horas antes de instalar la capota. Con temperatura, esta capota se instalará rápidamente.

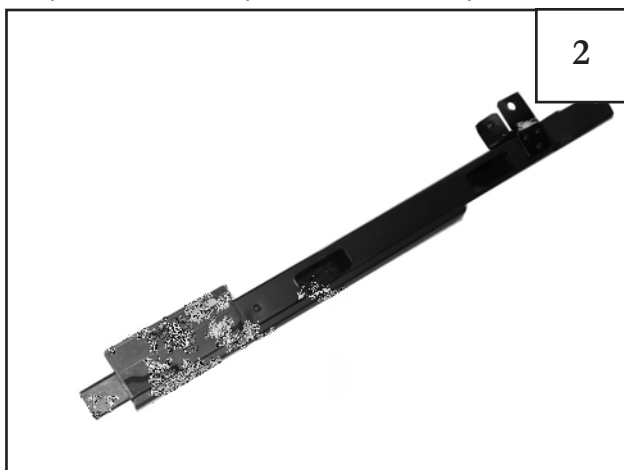

Para ensamblar el marco de la puerta, inserte la barra de extrusión delantera en la esquina del premontaje de la pieza horizontal superior, como se muestra.

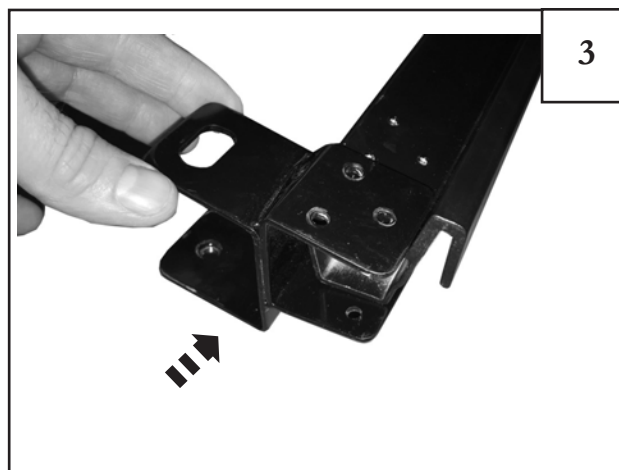

Instale el soporte trasero en el extremo trasero de la barra de extrusión trasera al deslizarlo para alinear los orificios, como se muestra. No atornille en este momento.

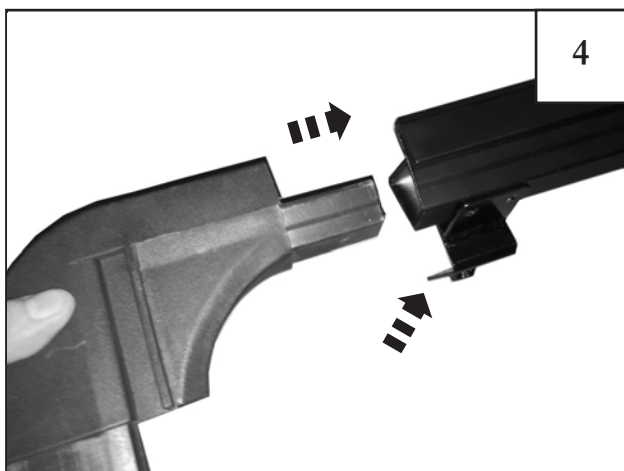

Con el soporte en el lugar, inserte la esquina de plástico en la barra de extrusión trasera.

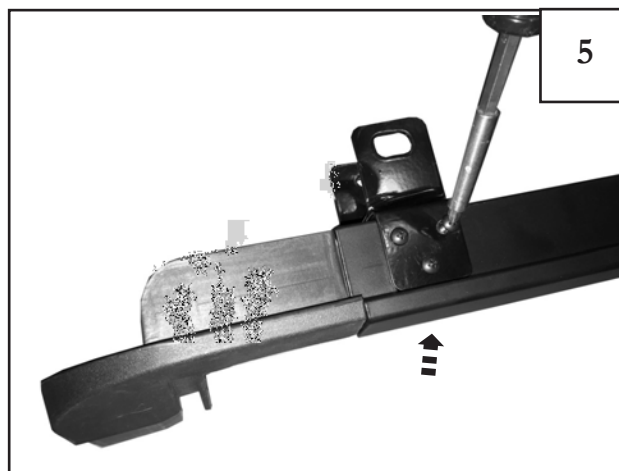

Use 3 tornillos para ajustar la esquina de plástico y el soporte trasero, como se muestra.

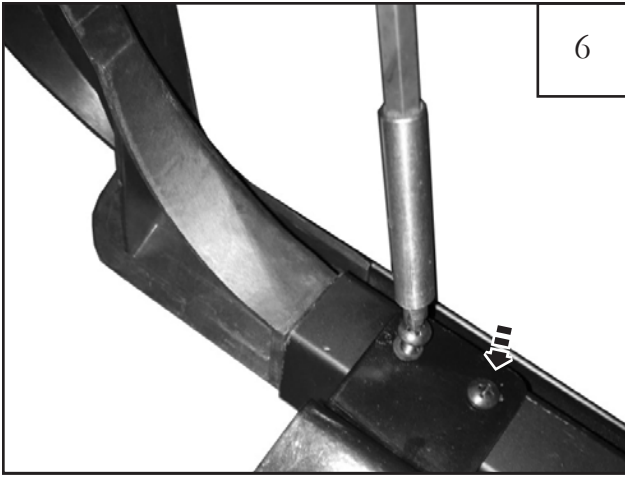

6

Gire el marco de la puerta para acceder al lado inferior. Con 2 tornillos, ajuste la esquina de plástico, como se muestra.

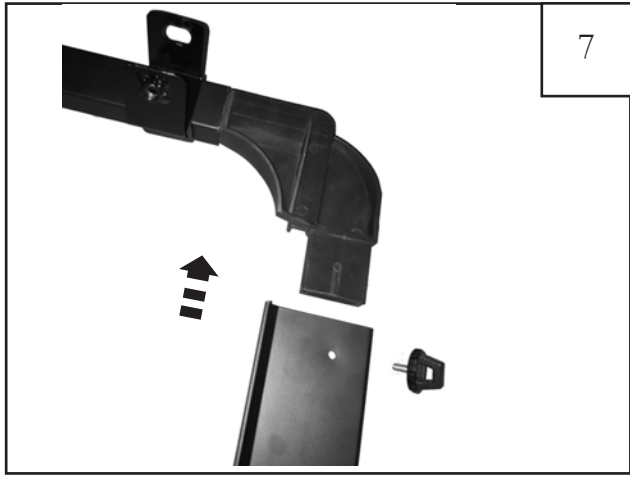

7

Inserte el otro extremo de la esquina de plástico en la barra de extrusión vertical y ajuste con el tornillo de la perilla de giro.



8

Instale y ajuste con el tornillo de la perilla de giro, como se muestra.

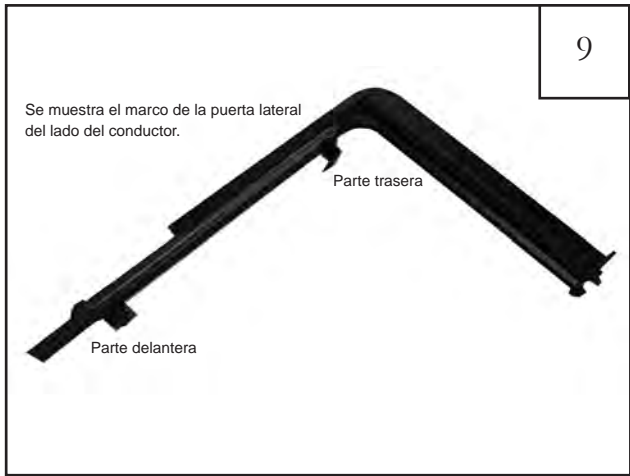

9

El ensamblaje del marco de la puerta ahora está completo. Repita estos pasos (pasos 2 al 9) para ensamblar el marco de la otra puerta.

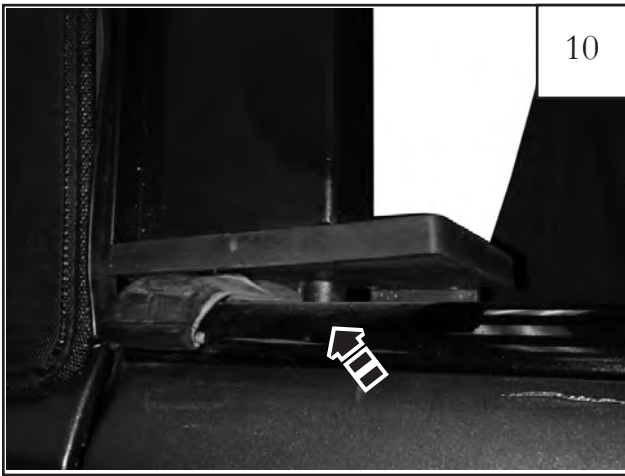

10

Coloque todo el marco de la puerta en el vehículo y encaje el pasador de la base inferior en el orificio de la base del vehículo cerca del pestillo de la puerta delantera.



11

Coloque el soporte trasero del marco de la puerta en el vehículo y ajuste el soporte sobre la barra deportiva.

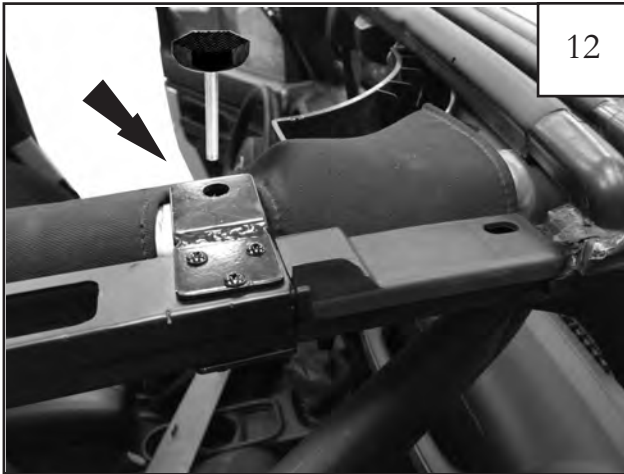

Coloque el soporte delantero del marco de la puerta en el vehículo y ajuste el soporte sobre la barra deportiva.

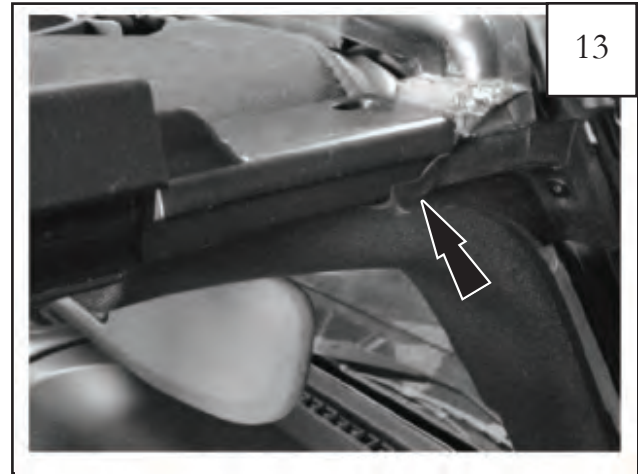

CONSEJO: Asegúrese de que la junta de goma en la parte superior del parabrisas esté correctamente sellada contra la sección del marco de la puerta delantera. Vea la fotografía para saber cómo debe ser el ajuste apropiado y verifique que el sello de espuma de fábrica esté en su lugar.



Coloque la placa de montaje del lado del conductor encima de todo el marco superior de la puerta en el vehículo y acomode el soporte sobre la barra antivuelco. Alinee el orificio delantero con el soporte delantero del marco de la puerta. Repita este paso de ambos lados.



Comenzando en el orificio del soporte delantero, inserte la perilla del marco de la puerta en el orificio y ajústela. Repita los pasos 14 al 15 del otro lado.



Coloque la correa de retención superior en el orificio de la placa de montaje del marco de la puerta ubicado en la parte trasera. Ubique el orificio no utilizado en la parte trasera de la placa del marco de la puerta, como se muestra. Nota: Solo hay una correa y está instalada del lado del conductor.



Coloque la correa de retención en su lugar con el perno a través del ojal de goma, como se muestra. A continuación, instale la segunda arandela y la tuerca Nylock en la parte superior de la correa y apriete con una llave de cubo de 13 mm y una llave de 13 mm.



Cuando la parte superior esté en la posición plegada hacia atrás, alcance y enganche la correa de retención sobre la barra como se muestra. **Nota: La correa se usa para fijar de forma segura la capota en la posición abierta a altas velocidades.**



Asegúrese de desenganchar la correa de retención de la barra antes de plegar la parte superior hacia adelante otra vez.



Use una punta Torx T25 para extraer la manija del parabrisas, tanto del lado del conductor como del lado del pasajero, como se muestra.



Instale el pestillo provisto, como se muestra, y vuelva a fijarlo con la punta Torx T25 del paso anterior.

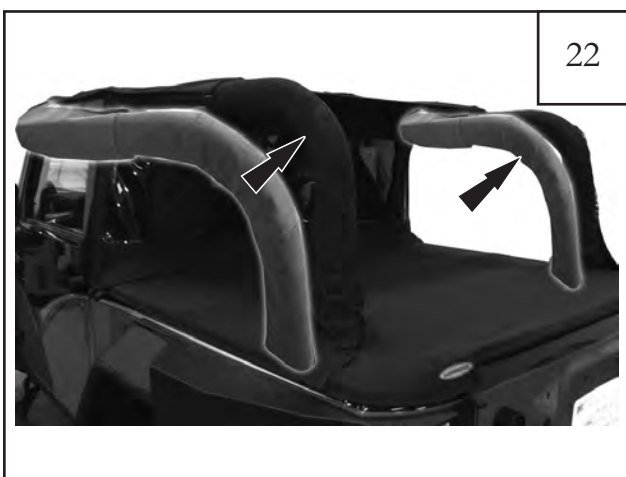

Instale la envoltura del cobertor de la barra deportiva en la barra deportiva.



Envuelva la base de la barra deportiva, como se muestra.



24

Comenzando en la parte inferior de la base de la barra deportiva. Meta el cinturón de seguridad dentro de las cubiertas de la barra deportiva, como se muestra.



25

Ubique las cremalleras, y conecte y cierre las cremalleras, como se muestra, en cada lado.



26

Cierre la cremallera curva superior y conecte la solapa de velcro para cerrar.



27

Asegure el velcro, como se muestra. Repita los pasos 22-27 para el otro lado.



28

Coloque el ensamble de tubos de montaje de la capota encima de la tela de la cubierta principal y, luego, insértelo en el bolsillo delantero. Asegure con broches de presión, como se muestra. **Consejo: Coloque el tubo de metal delantero en los bolsillos de las esquinas y tire hasta el final hasta que quede ajustado.**

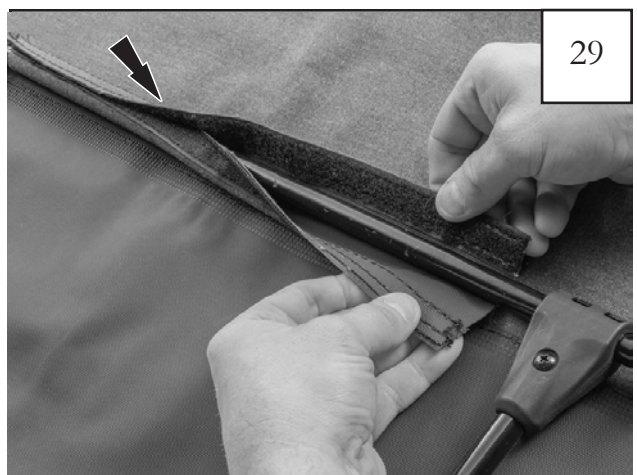

29

Fije el tubo de capota abatible a la capota principal de la cubierta con las solapas con cierre de velcro, como se muestra, en ambos lados.

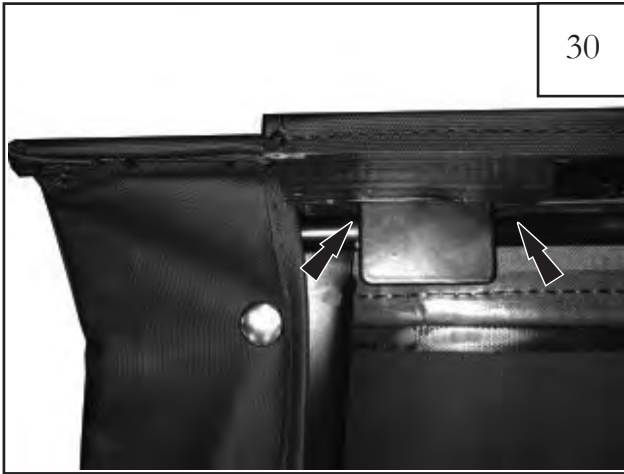

30

Inserte la tira de plástico en la pieza de metal cuadrada para ajustar correctamente, como se muestra, en ambos lados.



31

CONSEJO: Coloque el lado superior hacia abajo y vuelva a plegar desde la parte de la ventana trasera. Puede ser útil contar con la ayuda de otra persona en este paso.

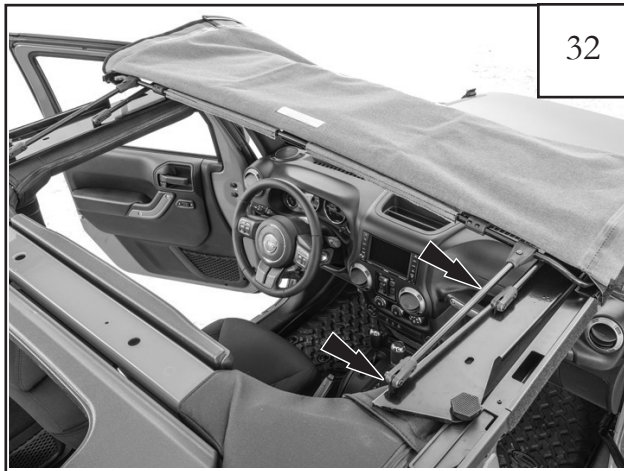

32

Levante la capota plegada y los componentes de montaje hacia la parte superior de la barra deportiva Wrangler. Colóquela y céntrala hacia la junta del parabrisas delantero, y alinee las 4 abrazaderas del punto de pivote, como se muestra.



33

Con la llave Allen de 4 mm suministrada, instale los pernos de reborde desde el exterior de cada enganche del cabezal de ensamblaje de la capota y ajuste cada perno con 4 tuercas de presión. La tuerca de presión encajará en el plástico.



34

Presione firmemente el cabezal de ensamblaje de la capota abatible contra el sello del parabrisas y enganche para sujetarlo. Para lograr un ajuste firme y adecuado de los pestillos, desatornille cada pestillo de enganche delantero donde el gancho de cierre solo llega al ensamblaje del cabezal.



35

Cierre y asegure los pestillos delanteros, como se muestra, en ambos lados.



36

Despliegue la capota sobre el bastidor de la barra deportiva hacia la parte trasera del vehículo.



37

Enrosque las dos correas sujetas a la sección central de la tela alrededor de la parte trasera y central de la barra de seguridad.



38

Inserte ganchos de plástico en los orificios de la parte inferior de la barra de seguridad. Tense la correa hasta que quede ajustada y, luego, enganche. **CONSEJO:** Si la capota está suelta en la parte superior, puede tensarla más para ajustarla.



39

Coloque el plástico del riel del cinturón de la cubierta principal en los laterales del marco de la puerta superior de adelante hacia atrás. Comience con la cabecera del parabrisas.

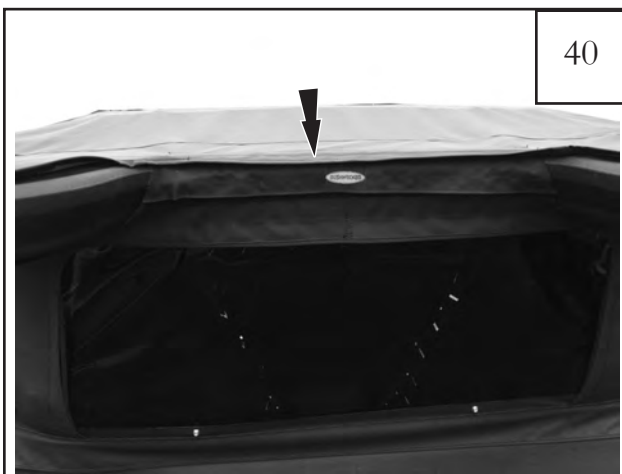

40

Instale la ventana trasera. Coloque la cremallera superior media desde la ventana posterior a la cubierta principal.

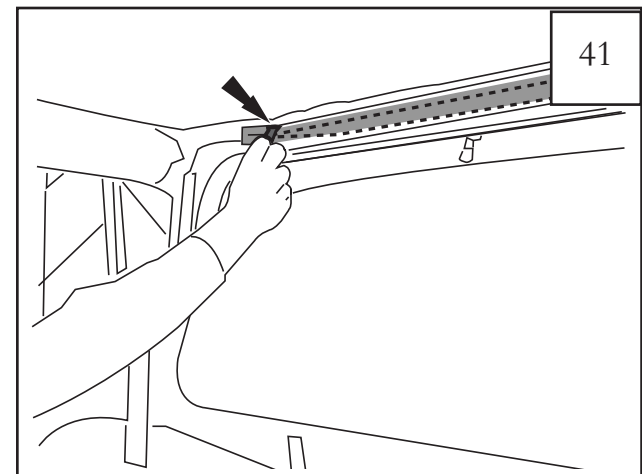

41

Desde el interior del Wrangler fije las cremalleras de la ventana trasera superior a la tela del cobertor principal con las cremalleras. **Nota:** Acceda desde el interior para cerrar la cremallera.



Coloque las correas laterales en las esquinas superiores de la ventana trasera. Desde dentro del Wrangler.



Sujete y ajuste las correas alrededor de la barra deportiva y pase el extremo por la hebilla, como se muestra. **Nota: Las correas deben estar apretadas y pueden ajustarse posteriormente para montar correctamente el cobertor de caja.**



Desde el exterior del Wrangler fije las cremalleras del soporte delantero a la tela del cobertor principal con las cremalleras. **Nota: Acceda desde el exterior para cerrar la cremallera.**

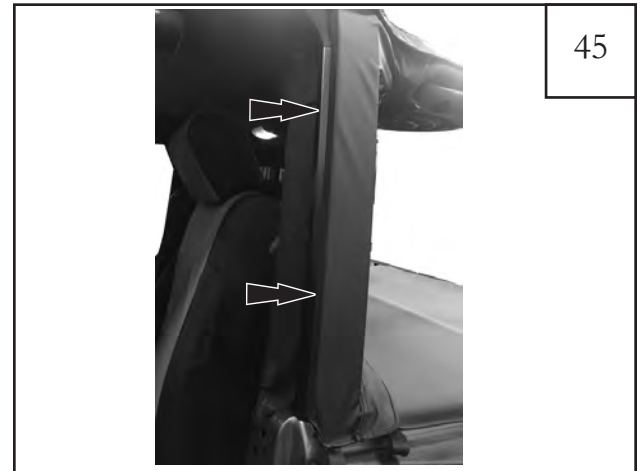

Inserte los laterales de la ventana trasera en los laterales del marco de la puerta al deslizar el respaldo de plástico en el marco de la puerta, como se muestra. Repita el mismo procedimiento para el otro lado. **Consejo: Comience en la parte superior y continúe hacia abajo. Luego, inserte una pequeña pestaña en la parte inferior.**



Conecte y cierre la solapa de velcro.



Se muestra la solapa en posición cerrada.



48

Ubique el plástico lateral y metal en la carcasa del altavoz y la barra deportiva al lado del borde del altavoz. **Nota: Las esquinas superiores de la ventana trasera en el lado del conductor y del pasajero.**



49

Ubique el plástico lateral y metal en el riel del cinturón de la base. **Nota: Las esquinas inferiores de la ventana trasera en el lado del conductor y del pasajero.**

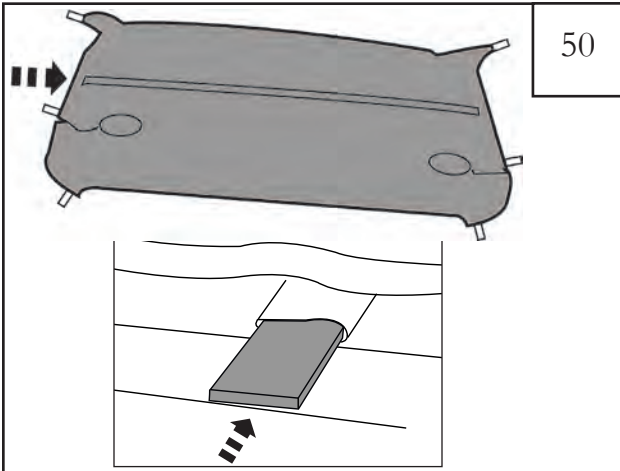

50

Coloque el cobertor de caja boca abajo para acceder a la manga del arco de soporte. Introduzca el arco de soporte del cobertor de caja en la manga del bolsillo.



51

Coloque la cubierta Tonneau en la parte posterior de la base y coloque la cubierta alrededor de la base de la barra deportiva, como se muestra. **Nota: No apriete los collarines en este momento, permita que permanezcan sueltos.**

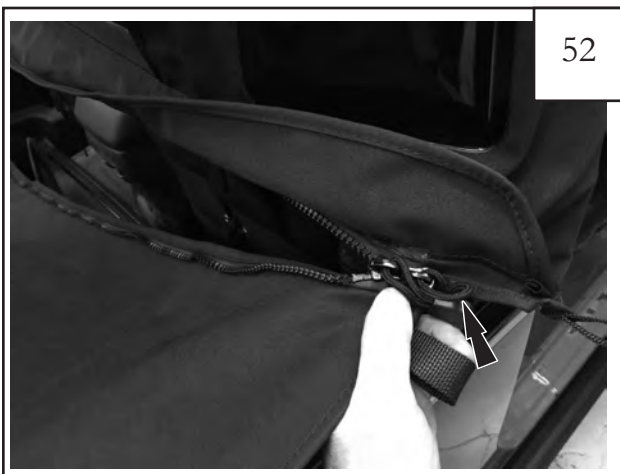

52

Comience en el lado del pasajero en la parte inferior de la ventana trasera y cierre el cobertor de caja en la ventana trasera.

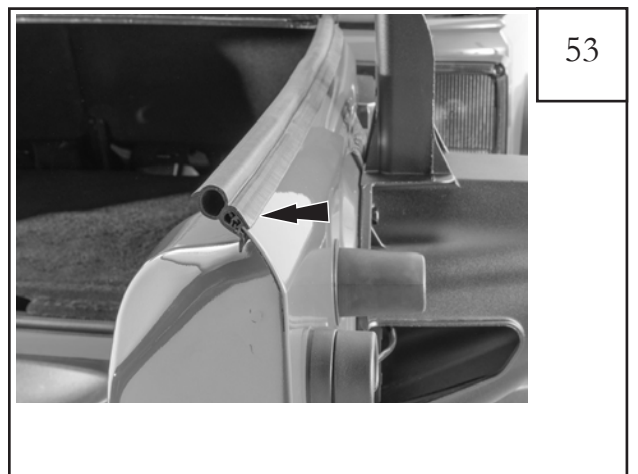

53

Instale el sello ubber en el borde superior de la puerta del extremo. Selle los puntos de cola hacia la parte delantera del vehículo.

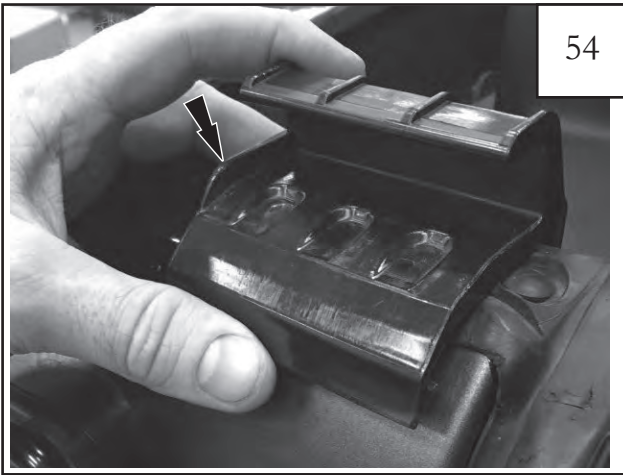

54

Instale el retén de plástico que va hacia afuera del vehículo. Instale el soporte de la barra enganchanto el borde trasero del retén en la base interior.

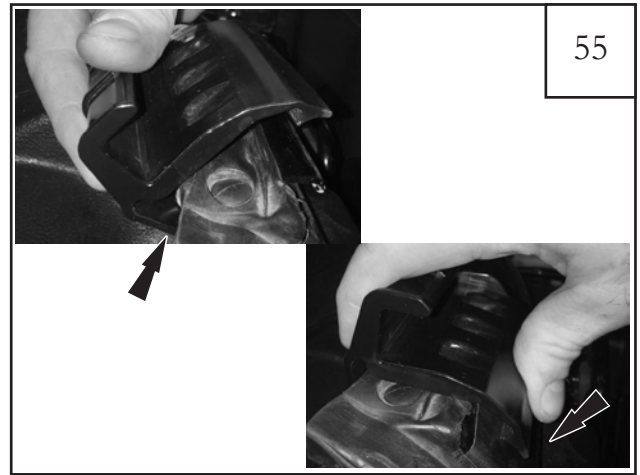

55

Cierre la abrazadera al presionar el borde delantero sobre la chapa metálica del riel del cinturón. La abrazadera se ajustará y se fijará en la parte inferior del borde del tubo.

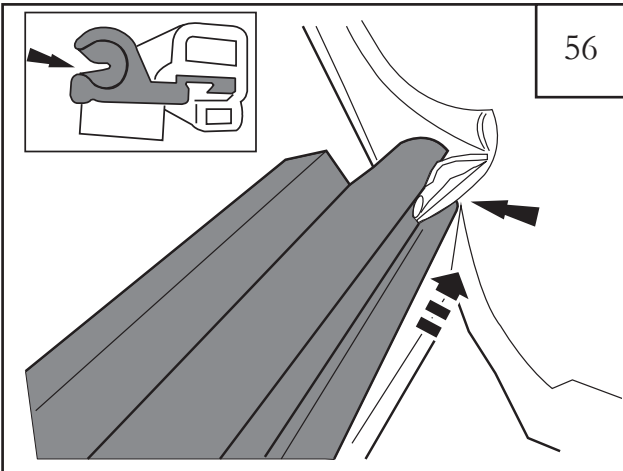

56

Deslice la barra de la puerta trasera por la parte trasera del cobertor de caja utilizando el riel C incorporado para guiarla sobre la solapa y el tubo pequeño.

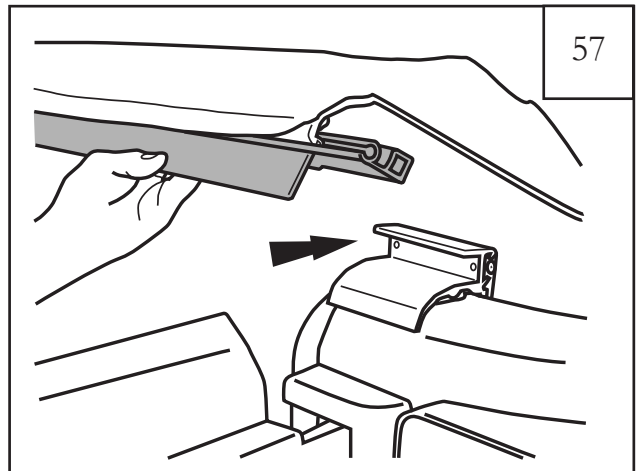

57

Introduzca la barra de la puerta trasera en los soportes al empujar la barra contra los soportes y girarla hacia su cuerpo.



58

Ubique el plástico lateral y métalo en el riel del cinturón de la base. **Nota: en el lado del conductor y del pasajero.**



59

Ubique el plástico lateral y métalo en el riel de la esquina. **Nota: en el lado del conductor y del pasajero.**

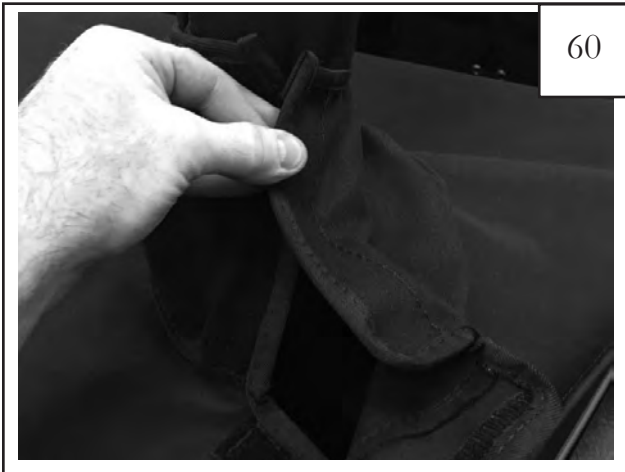

60

Conecte las solapas de velcro alrededor de la base de la barra deportiva. Asegúrese de que el cobertor de la barra deportiva esté adentro y, luego, coloque el cinturón de seguridad en el borde abierto.



61

La instalación de la capota está completa. Asegúrese de que todas las solapas con cierre de velcro estén cerradas.



62

Los siguientes pasos muestran el uso después de la instalación. Con el vehículo completamente detenido y estacionado en un área segura, destrabe los dos pestillos delanteros. Desprenda las tiras laterales con cierre de velcro fijadas a los marcos de las puertas superiores.



63

Tome la manija de agarre ubicada en el centro de la capota abatible y empuje hacia arriba. El bastidor girará hacia la parte posterior del vehículo y se apoyará sobre sí mismo.



64

Una vez que la capota esté abierta, recuerde acoplar la correa de retención para una velocidad superior a 55 mph [consulte el paso 18].



65

Para cerrar, pare el vehículo, salga de la carretera en un área segura y ponga el vehículo en modo estacionamiento. Retire la correa de retención, levante la manija de agarre central y empuje hacia arriba. Cierre ambos pestillos del parabrisas y vuelva a colocar los cierres de velcro en los marcos de la puerta. **¡Disfrute su Bushwacker Trail Armor Soft Top™!**



STEP 1 – PRIOR TO INSTALLATION

- A)** Bushwacker only approves installing the soft top according to these written instructions with the hardware provided. **WARNING:** Failure to install according to these instructions will invalidate the warranty. This includes, but is not limited to using alternative installation methods, hardware, or materials. For correct installation, temperature of mounting surface of part should be between 70-95°F (21-35°C) prior to installation.
- B) Care & Cleaning:** Bushwacker soft tops are built to last; Washing: The soft top fabric should be washed often using a mild soap, warm water and a soft bristle brush (do not use the brush on the window glass!). You can also use special soft top cleaners. Make sure that after cleaning you rinse with clear water to remove all traces of soap.
- C) Windows:** It is very important that you keep your windows clean! Use a mild soap and water solution to gently clean your windows. **NEVER** wipe your windows clean with a dry cloth! Dust and dirt on a dry cloth can scratch your windows causing “fogging” and permanent damage. When removing your windows, store them in the window storage bag provided.
- D) Pre-Installation requirements**
Remove existing hard or soft top on your Jeep Wrangler. For OEM (original/factory) soft tops, also remove the following parts:
- Windshield header bar
 - Tube frame hardware from roll bar
 - Side door surrounds
 - Rear window, tailgate bar, tailgate clips

Jeep® Wrangler 2007-2018 Toit Flatback Trail Armour 2 portes (JK)

N° de réf. BWT-15235

Rev-1 04/06/2018

Pour des informations complètes sur le montage,
visitez : www.bushwacker.com











OUTILS POUR FACILITER L'INSTALLATION :

- Tournevis Phillips
- Clé à cliquet et pièces de prolongement
- Embout Torx T25
- Clé hexagonale (Allen)
- Lunettes de protection

GARANTIE À VIE LIMITÉE CONTRE TOUT DÉFAUT DE FABRICATION

- Pour bénéficier de la garantie, vous devez fournir une preuve d'achat.

Contenu :

- | | | | | |
|--|--|--|--|---|
| 1.

Bâche principale
Trailview
1 pièce | 2.

Couvre-caisse
1 pièce | 3.

Arrière
Fenêtre
1 pièce | 4.

Housse de la
barre de sport.
2 pièces | 5.

Lame de charnière
gauche
1 pièce |
| 6.

Lame de charnière
droite
1 pièce | 7.

Attache en plastique du hayon
2 pièces | 8.

Barre de hayon
1 pièce | 9.

Vis autotaraudeuse
22 pièces | 10.

Boulon à épaulement
4 pièces |

Contenus (suite)



11. Matériel du toit ouvrant
1 pièce



12. Horizontale supérieure droite, 1 pièce



13. Horizontale supérieure gauche, 1 pièce



14. Montant vertical gauche, 1 pièce



15. Montant vertical de droite, 1 pièce



16. Coin supérieur en plastique gauche
1 pièce



17. Coin supérieur en plastique de droite, 1 pièce



18. Caisse Support
1 pièce



19. Loquet avant, 2 pièces



20. Support de porte avant
2 pcs



21. Bouton de serrage
2 pièces



22. Sangle de retenue supérieure
1 pièce



23. Écrous, 4 pièces



24. Bouton de châssis de porte
Long, moyen, court;
6 pièces



25. Porte Arrière Support
Arrière 2 pcs

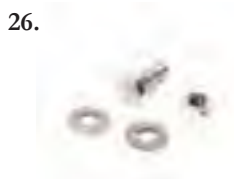

26. sangle matériel
(Bolt, Washer, Nut)
1 pcs



N'OUVREZ NI NE FERMEZ JAMAIS VOTRE TOIT AMOVIBLE DURANT LA CONDUITE OU DURANT TOUT DÉPLACEMENT DU VÉHICULE. VOTRE VÉHICULE ET VOTRE TOIT AMOVIBLE RISQUENT DE S'ENDOMMAGER. GAREZ-VOUS DANS UN ENDROIT SÛR ET ACTIONNEZ LE FREIN À BRAS AVANT DE RABATTRE OU DE FIXER VOTRE TOIT AMOVIBLE.

Procédures de montage :



Important : Pour un ajustement souple et une installation facile, ce toit doit être installé à des températures supérieures à 72 degrés. En dessous de cette température, le tissu peut rétrécir d'un pouce ou plus, rendant ainsi l'installation difficile. Nous vous recommandons vivement de retirer votre nouveau toit TrailView Tonneau Top^{MC} de l'emballage et le conserver dans un endroit chauffé ou de l'exposer aux rayons du soleil pendant 1 à 2 heures avant de l'installer. Une fois ramolli par la chaleur, ce toit s'installe rapidement.

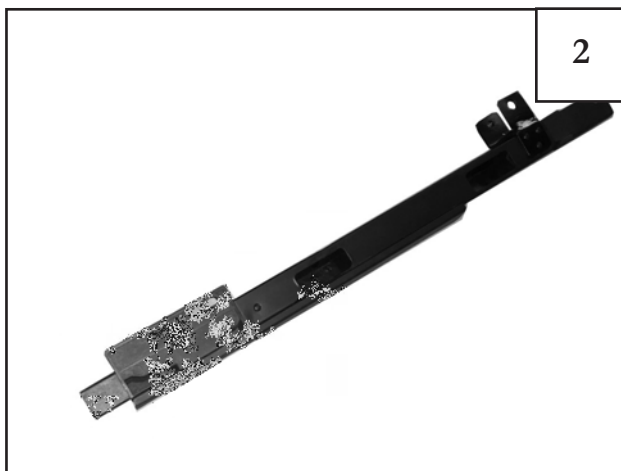

Assemblez le châssis de porte en insérant la barre d'extrusion avant dans le préassemblage de la partie supérieure horizontale du coin, comme illustré.

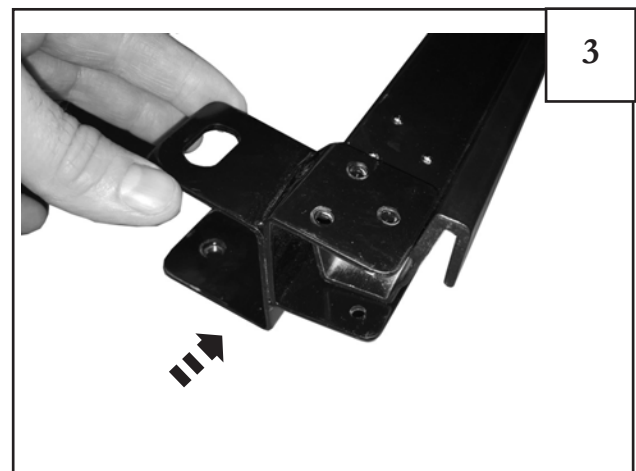

Faites glisser le support arrière sur l'extrémité arrière de la barre d'extrusion pour aligner les trous comme indiqué. Ne vissez pas pour le moment.

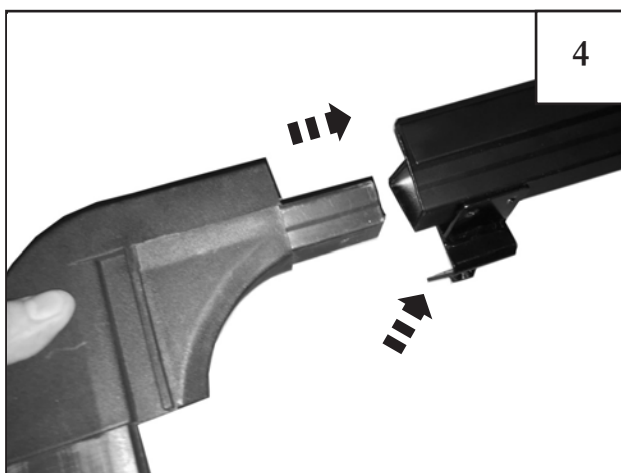

Avec le support en place, insérez le coin en plastique dans l'extrusion arrière.

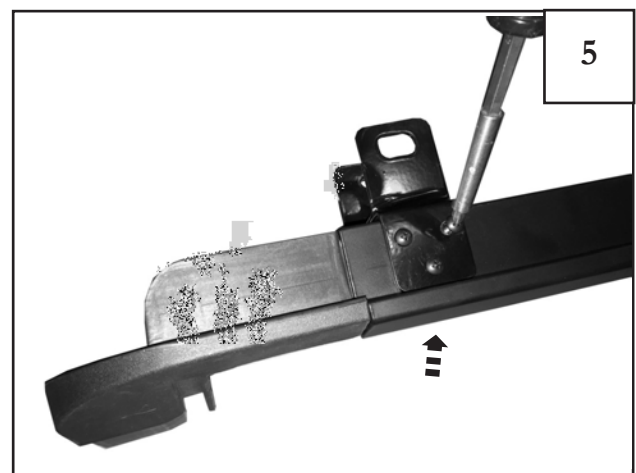

À l'aide de 3 vis, fixez ensemble le coin en plastique et le support arrière comme indiqué.

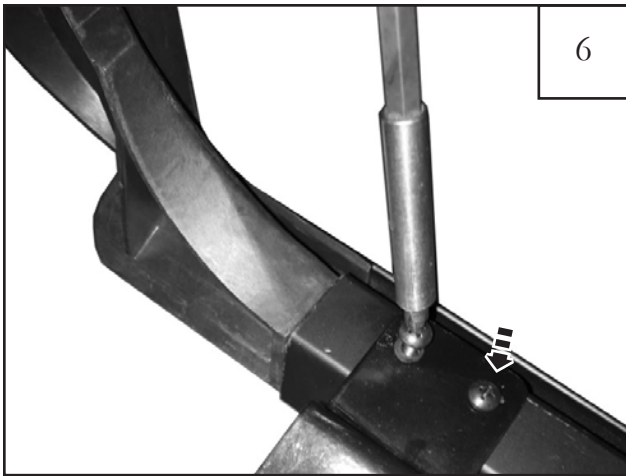

6
Retournez le châssis de porte pour voir l'autre face. Avec 2 vis, serrez le coin en plastique, comme indiqué.

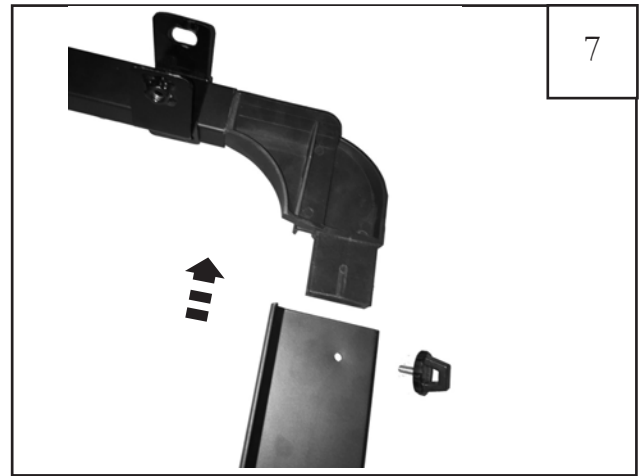

7
Insérez l'autre extrémité du coin en plastique dans la partie d'extrusion verticale et fixez-la à l'aide du bouton de serrage.



8
Montez et fixez avec le bouton de serrage comme indiqué.



9
L'assemblage du châssis de porte est maintenant terminé. Répétez les étapes 2 à 9 pour assembler l'autre cadre du châssis de porte.

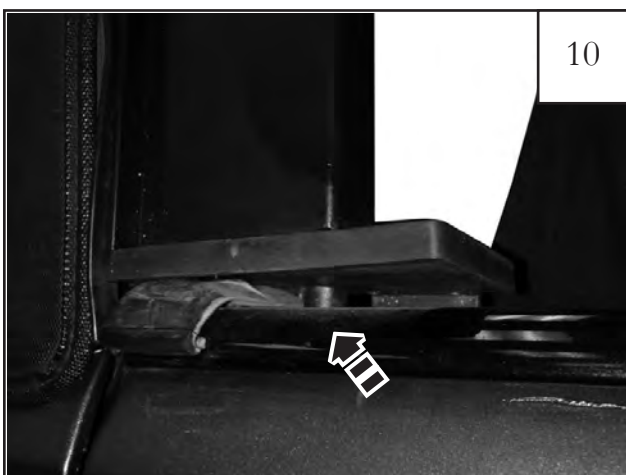

10
Placez le châssis de porte complété sur le véhicule et insérez la goupille de la base dans le trou dans le bac du véhicule près du loquet de la porte avant.



11
Positionnez le support arrière du châssis de porte sur le véhicule et ajustez le support sur la barre de sport.

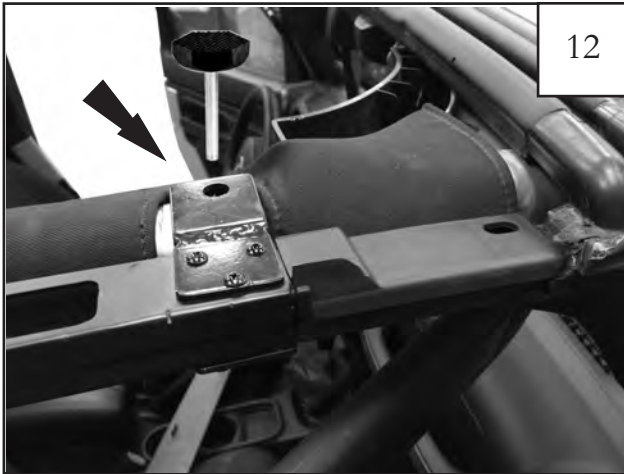

12

Positionnez le support avant du châssis de porte sur le véhicule et ajustez le support sur la barre de sport.

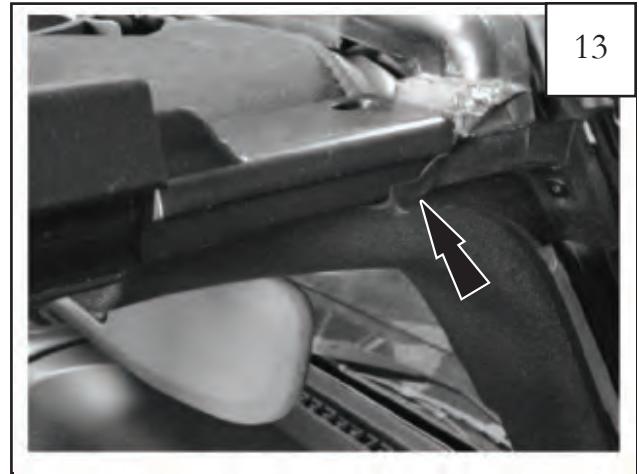

13

CONSEIL : Assurez-vous que le joint en caoutchouc en haut du pare-brise isole bien la partie du châssis de porte avant. Consultez la photo pour vérifier que tout est bien ajusté et vérifiez que le joint en mousse d'origine est en place.



14

Placez la plaque de montage du côté conducteur au-dessus du châssis de porte complété sur le véhicule et ajustez le support sur l'arceau de sécurité. Alignez le trou avant sur le support avant du châssis de porte. Répétez cette étape de l'autre côté.



15

En commençant au niveau du trou du support avant, enfoncez le bouton du châssis de porte dans le trou et serrez. Recommencez les étapes 14 et 15 de l'autre côté.



16

Ajustez la sangle de retenue supérieure au trou de la plaque de montage du châssis de porte situé à l'arrière. Repérez le trou inutilisé à l'arrière de la plaque du châssis de porte, comme indiqué. Remarque : Il n'y a qu'une seule sangle et elle est installée côté conducteur.



17

Positionnez la sangle de retenue avec le boulon à travers le passe-fil comme indiqué. Ensuite, installez la deuxième rondelle et l'écrou à frein élastique sur le dessus de la sangle et serrez avec une clé à douille de 13 mm et une clé de 13 mm.



18

Lorsque le toit est replié à l'arrière, soulevez et accrochez la sangle de retenue au-dessus de la barre, comme indiqué. **Remarque : La sangle est utilisée pour fixer en toute sécurité le toit amovible en position ouverte à vive allure.**



19

Assurez-vous de décrocher la sangle de retenue de la barre avant de replier le toit vers l'avant.



20

Utilisez un embout Torx T25 pour retirer la boucle de fantassin du pare-brise du côté du conducteur et du passager, comme illustré.



21

Installez le loquet fourni comme illustré et fixez-le avec le boulon Torx T25 utilisé à l'étape précédente.

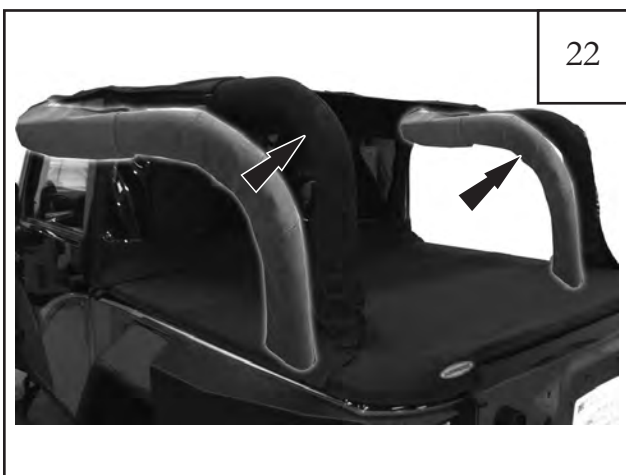

22

Installez l'enveloppe de la housse de la barre de sport sur la barre



23

Enveloppez la base de la barre de sport comme indiqué.

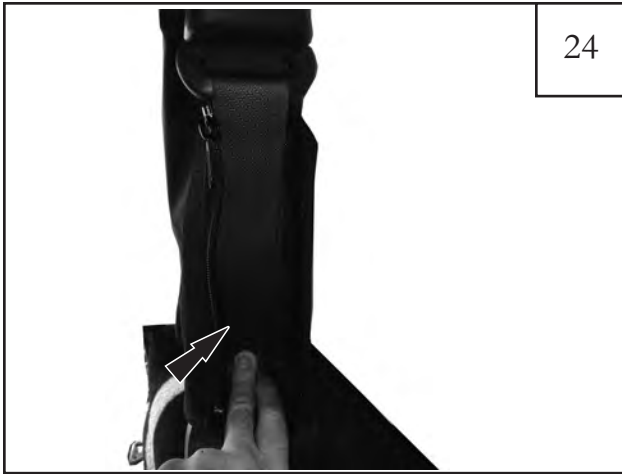

24

À commencer par la base de la barre de sport. Faites rentrer la ceinture de sécurité au-dedans des housses de la barre de sport comme indiqué.



25

Retrouvez les fermetures à glissière, reliez les deux bandes puis remontez la tirette de chaque côté comme indiqué.

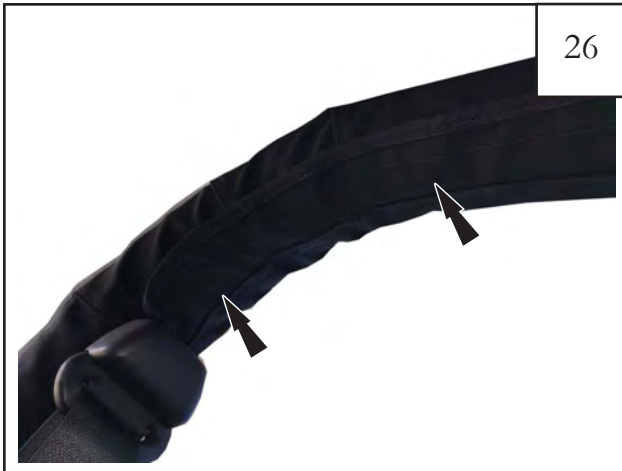

26

Remontez la fermeture à glissière incurvée du haut puis raccordez le rabat velcro pour le fermer.



27

Fixez la bande velcro comme indiqué. Recommencez les Étapes 22 à 27 de l'autre côté.



28

Placez l'assemblage des tubes de fixation du toit au-dessus de la bâche principale, puis insérez-le dans la poche avant. Comme illustré, fixez-le avec des attaches. **Conseil : Placez le métal avant dans les poches d'angle et enfoncez-le jusqu'au bout.**

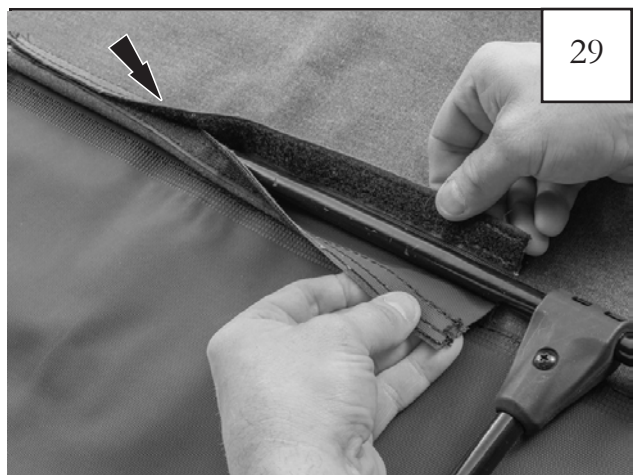

29

Comme illustré, fixez le tube du toit ouvrant à la bâche principale du toit amovible en attachant les rabats velcro des deux côtés.

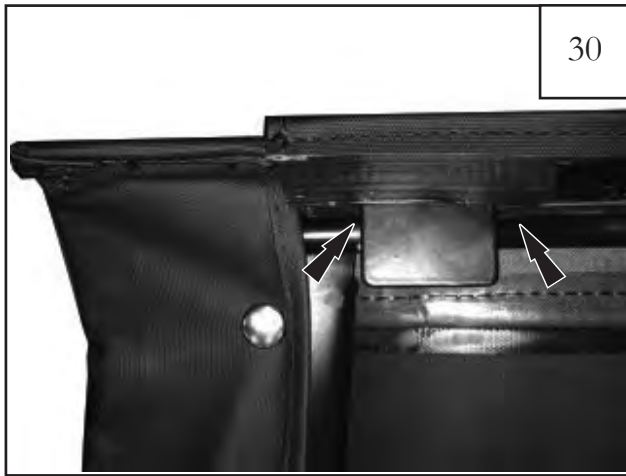

30

Comme indiqué, rentrez la bande en plastique des deux côtés dans la pièce de métal carrée pour bien l'ajuster.



31

CONSEIL : Posez la face supérieure retournée vers le bas et repliez en commençant par la partie de la fenêtre arrière. Il est préférable d'être à deux pour le faire.



32

Soulevez le toit amovible plié et l'ensemble du matériel au-dessus de la barre de sport Wrangler. Placez et centrez vers le joint d'étanchéité du pare-brise avant et alignez les 4 pinces de point de pivotement comme indiqué.



33

À l'aide de la clé Allen de 4 mm fournie, installez les boulons à épaulement depuis l'extérieur de chaque articulation de l'assemblage de la traverse du toit amovible et serrez chaque boulon avec un contre-écrou (4 places). L'écrou de blocage s'ajustera dans le plastique.



34

Tirez fermement l'assemblage de la traverse du toit ouvrant contre le joint du pare-brise et accrochez-le. Pour bien ajuster les loquets, dévissez chaque vis du crochet de verrouillage avant là où il atteint l'assemblage de la traverse.



35

Maintenant, comme indiqué, fermez et bloquez les loquets avant des deux côtés.



Dépliez le toit amovible par-dessus le cadre de la barre de sport en direction de l'arrière du véhicule.



Attachez les deux sangles de la section centrale du tissu à l'arrière de la barre audio, au milieu.

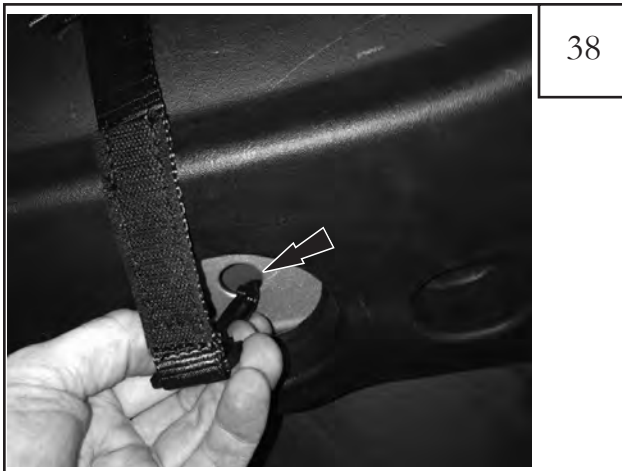

Insérez les crochets en plastique dans les trous sur le dessous de la barre audio. Serrez la sangle jusqu'à ce qu'elle soit bien serrée, puis accrochez-la en boucle.
CONSEIL : Si le toit amovible semble desserré en haut, il faut serrer encore plus les sangles.



Fixez le plastique du rail principal de la ceinture dans le châssis de la porte supérieure, de l'avant vers l'arrière. Commencez par la traverse du pare-brise.

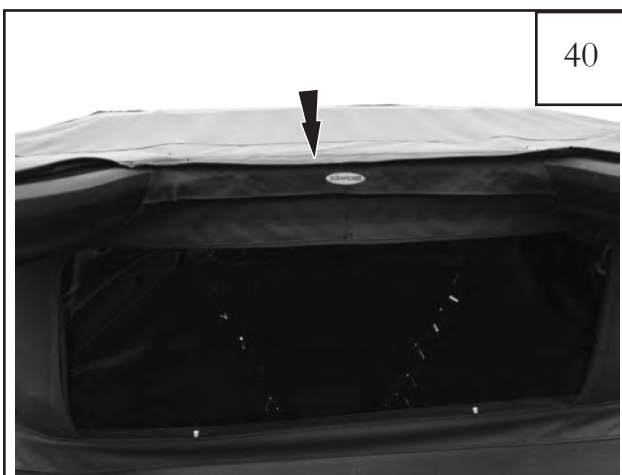

Installez la fenêtre arrière. Joignez la fermeture à glissière supérieure du milieu à partir de la fenêtre arrière jusqu'à la couverture principale.

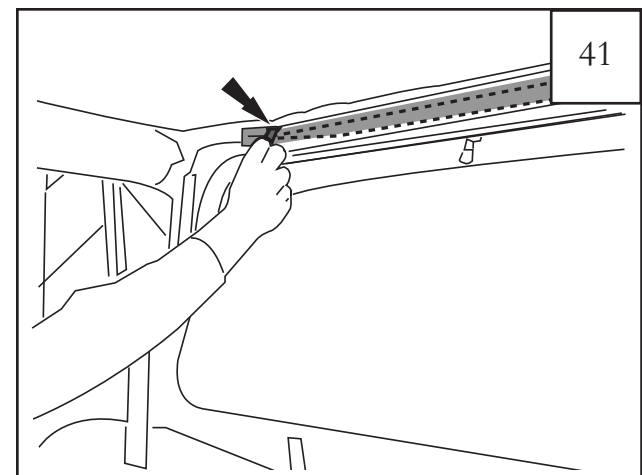

À partir de l'intérieur du Wrangler, joignez la fermeture à glissière de la fenêtre arrière supérieure au tissu de la couverture principale en fermant les fermetures à glissière. **Remarque : La fermeture à glissière initiale est accessible depuis l'intérieur.**



42

Repérer les sangles du coin latéral aux coins supérieurs de la fenêtre arrière. À partir de l'intérieur du Wrangler.



43

Connecter et serrer les sangles autour de la barre de sport, enfiler l'extrémité à travers la boucle, comme illustré. **Remarque : Les sangles peuvent être simplement positionnées et serrées après pour bien fixer.**



44

À partir de l'extérieur du Wrangler, remontez la fermeture à glissière à partir du châssis de la porte supérieure vers le tissu de la couverture principale en fermant les fermetures à glissière. **Remarque : La fermeture à glissière initiale est accessible depuis l'extérieur.**

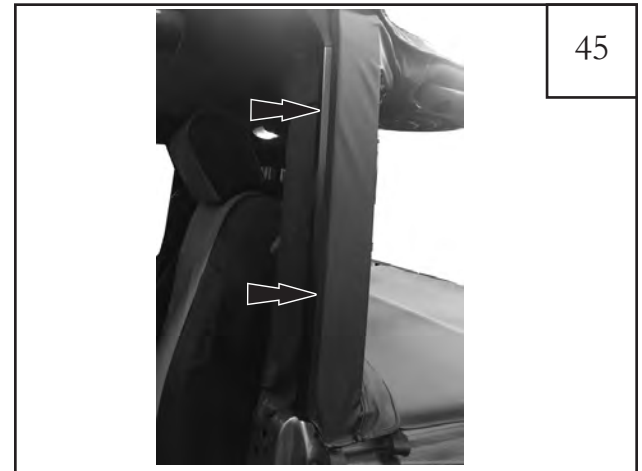

45

Rentrez les côtés de la fenêtre arrière dans les côtés du châssis de la porte en faisant glisser le support en plastique dans le châssis de la porte comme indiqué. Répétez la même procédure de l'autre côté. **Conseil : Commencez par le haut et progressez vers le bas. Faites rentrer ensuite les petites languettes en bas.**



46

Raccordez et fermez le rabat velcro



47

Illustration d'un rabat en position fermée.



48

Retrouvez le bord en plastique et faites-le rentrer dans le logement du haut-parleur et de la barre de sport à côté du bord du haut-parleur. **Remarque :** Les coins supérieurs de la fenêtre arrière du côté du conducteur et du passager.



49

Retrouvez le bord en plastique et faites-le rentrer dans le rail de la ceinture du bac. **Remarque :** Les coins inférieurs de la fenêtre arrière du côté du conducteur et du passager.

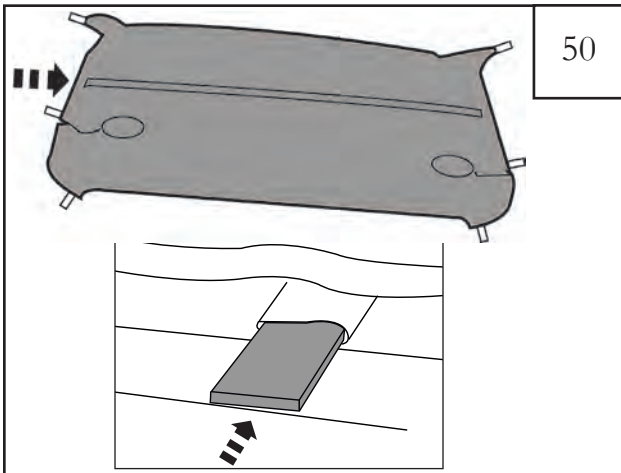

50

Posez le couvre-caisse à l'envers pour pouvoir accéder au manchon de l'arceau de support. Insérez l'arceau de support du couvre-caisse dans la poche fourreau.



51

Posez le couvre-caisse sur l'arrière du bac et placez la couverture autour de la base de la barre de sport comme indiqué. **Remarque :** Pour le moment, le fait de ne pas serrer les colliers permet une certaine mobilité.



52

Commencez par le côté passager depuis le bas de la fenêtre arrière et tirez la fermeture à glissière du couvre-caisse et continuez dans la direction de la fenêtre arrière.

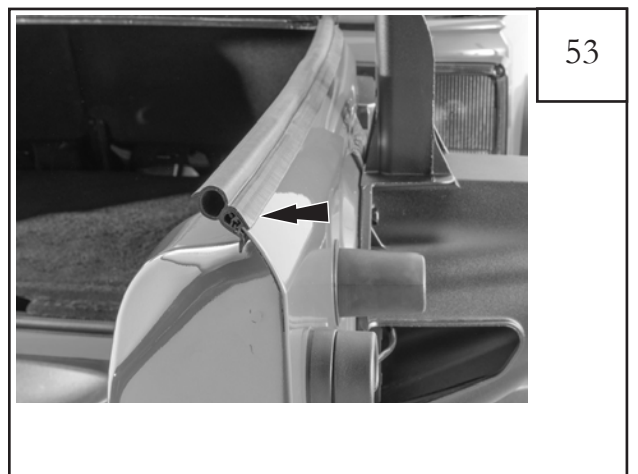

53

Installez le joint en caoutchouc sur le bord supérieur de la porte arrière. Scellez les points arrière vers l'avant du véhicule.

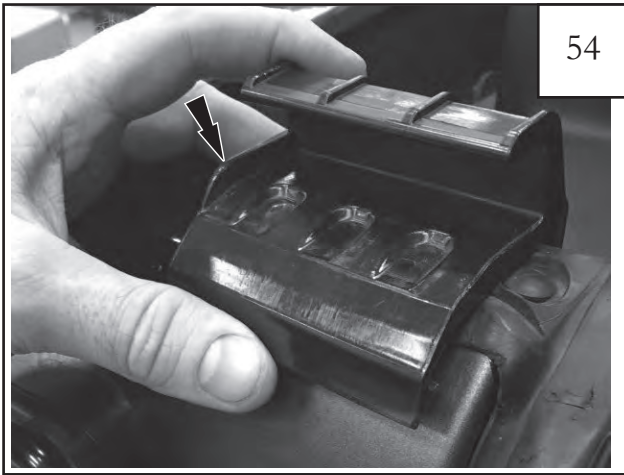

54

Installez l'attache en plastique de sorte qu'elle aille à l'extérieur du véhicule. Quant à celle de la barre du hayon, elle doit être accrochée au bord arrière de l'attache à l'intérieur du bac.

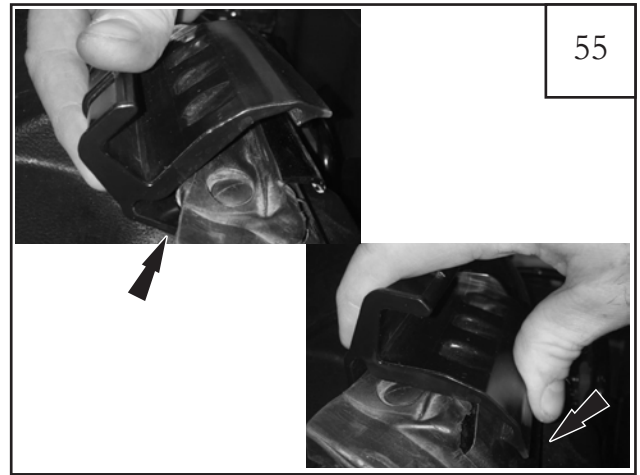

55

Fermez la pince en appliquant une pression vers le bas sur la tôle du rail de ceinture. L'attache s'enclenchera et se bloquera sous le rebord du tube.

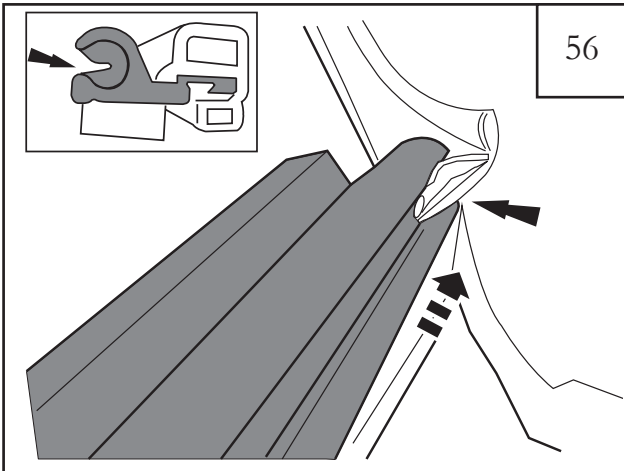

56

Faites glisser la barre du hayon sur le couvre-caisse arrière en utilisant le canal C intégré pour le guider sur le rabat et le petit tube.

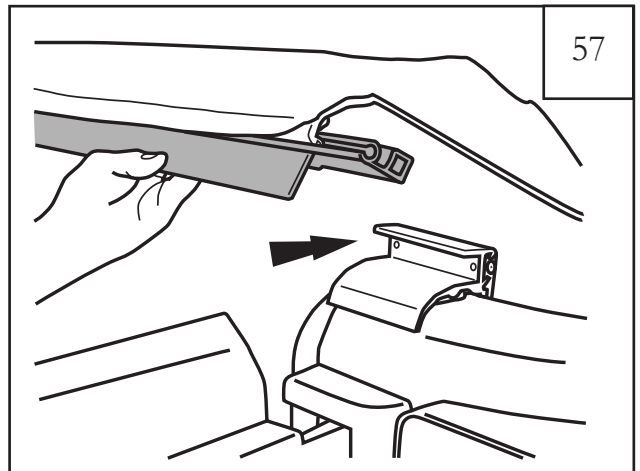

57

Insérez le hayon dans les supports en poussant la barre contre les supports et en le retournant en direction de votre corps.



58

Retrouvez le bord en plastique et faites-le rentrer dans le rail de la ceinture du bac. **Remarque : du côté du conducteur et du passager.**



59

Retrouvez le bord en plastique et faites-le rentrer dans le rail de la ceinture du coin. **Remarque : du côté du conducteur et du passager.**



Relier et fixer la bande velcro autour de la base de la barre de sport. Assurez-vous que la housse de la barre de sport est bel et bien à l'intérieur, puis placez la ceinture de sécurité dans le bord ouvert.



L'installation du toit amovible est maintenant terminée. Assurez-vous que tous les rabats velcro sont fermés.



Les étapes suivantes montrent l'utilisation après l'installation. Lorsque votre véhicule est complètement garé dans une zone sûre, déverrouillez les deux loquets avant. Défaites les bandes velcro latérales attachées aux châssis supérieurs des portes.



Attrapez la poignée centrale de l'abattant et poussez vers le haut. Le cadre pivotera vers l'arrière du véhicule et reposera sur lui-même.



Une fois le toit amovible ouvert, n'oubliez pas de fixer la sangle de retenue pour une vitesse supérieure à 55 mi/h (88 km/h) [reportez-vous à l'étape 18].



Pour fermer, sortez de la route dans un endroit sûr, arrêtez le véhicule et actionnez le frein à bras. Retirez la sangle de retenue, puis soulevez la poignée centrale et poussez vers le haut. Verrouillez les deux loquets du pare-brise et fixez à nouveau les attaches velcro sur les châssis de porte. Profitez de votre **Bushwacker Trail Armor Soft Top™!**