

Please read these instructions completely before proceeding with installation

Air Spring Kit Parts List

Item	Description	Quantity
A	Air Sleeve	2
B	Upper Bracket (driver-side shown)	2
C	Lower Bracket	2
D	Elbow Fitting	2
E	Nylon Nut	2
F	Star Washer	2
G	1/2" Flat Head Screw	2
H	5/16" Self Tapper	4
I	5/16" Long Self Tapper	4
AA	Air Line Assembly	16'
BB	Tie Strap	6
CC	Valve Cap	2
DD	5/16" Flat Washer	2
EE	Rubber Washer	2
FF	Small Star Washer	2
GG	5/16" Hex Nut	4

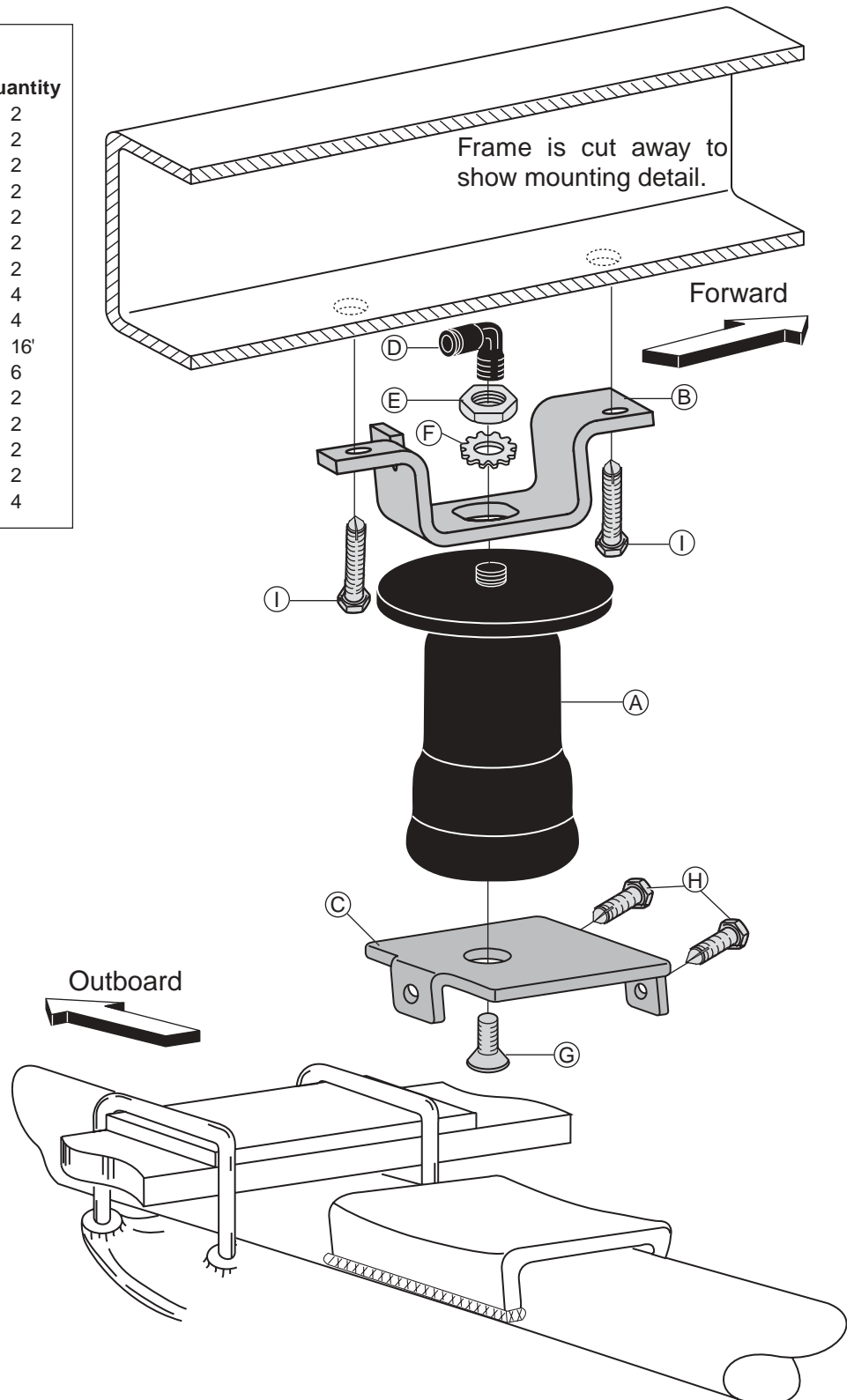

Figure 1

Tools Needed

1/2", 9/16" open-end or box wrenches

Crescent Wrench

Ratchet with 9/16" and 1/2" deep well sockets

5/16" drill bits (very sharp)

Heavy Duty Drill

Torque Wrench

Hose Cutter, Razor Blade, or Sharp Knife

Hoist or Floor Jacks

Safety Stands

Safety Glasses

Air Compressor, or Compressed Air Source

Spray Bottle with Dish Soap/Water Solution

IMPORTANT: Your vehicle may be equipped with a rear brake proportioning valve. Any type of load assist product could affect brake performance. We recommend that you check with your dealer before installing this type of product. If your vehicle DOES NOT have a rear brake proportioning valve or is equipped with an anti-lock type brake system, installation of a load assist product will have NO EFFECT ON BRAKE SYSTEM PERFORMANCE.

IMPORTANT: Failure to maintain correct minimum pressure (or pressure proportional to load), bottoming out, overextension, or rubbing against another component will void the warranty.

DANGER: Compressed air can cause injury and damage to the vehicle and parts if it is not handled properly. For your safety, do not try to inflate the air springs until they have been properly secured to the vehicle.

I. Getting Started

1. Jack up the vehicle and support the axle with jack stands.
2. Remove the jounce bumper. Remove the bolt before the ABS/brake bracket. Move bracket aside.

II. Assembling the Air Springs

1. Install the elbow fitting (D) to the top of the air spring (A) finger tight plus 1 1/2 turns. Be careful to only tighten on the metal hex nut only (Figure 1).
2. Set the upper bracket (B) over the elbow fitting on the air spring and onto the threaded post.
3. Install 3/4" star washer (F) and nylon nut (E) onto the threaded post (Figure 1). Tighten finger tight only.
4. Attach the lower bracket (C) to the assembly using the flat head screw (G). Refer to Figure 1. Tighten to 15 ft-lbs.

NOTE: The two tabs on the lower bracket and the wide leg on the upper bracket should face forward as shown in Figure 1.

III. Installing the Assembly

1. Assemble one of the air spring units. Index the upper bracket outboard with the threaded post facing inward.
2. Unscrew and remove the jounce bumper.
3. Set the air spring assembly in place on one side of the vehicle.

NOTE: The upper brackets are driver-side and passenger-side specific. The narrow leg on the upper bracket points rearward (Figure 1).

4. Line up the edge of the bracket with the inside framerail.
5. Using the bracket as a template, mark where holes will need to be drilled.
6. Remove the air spring assembly. Center punch and drill two $\frac{1}{4}$ " holes where marked.

7. Set the assembly back in place and attach with two long $\frac{5}{16}$ " self-tapping screws. **DO NOT OVERTIGHTEN.**

NOTE: Two sets of $\frac{5}{16}$ " self-tapping screws are supplied. Use the longer screws for this step.

8. Route the hose assembly away from heat sources.
9. Repeat steps 1-8 for the other side.

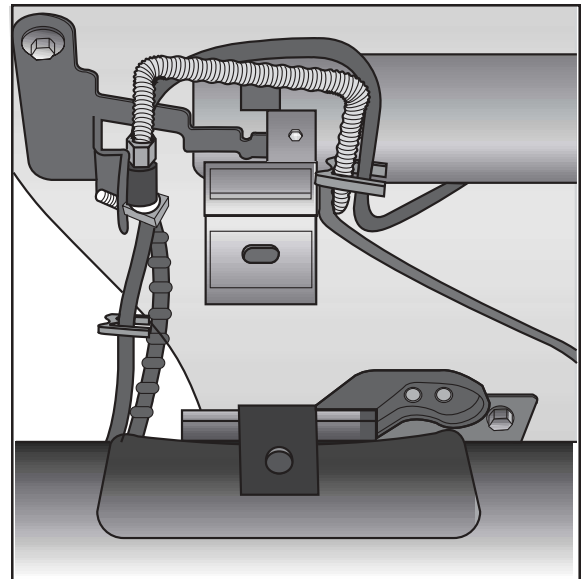

Figure 2

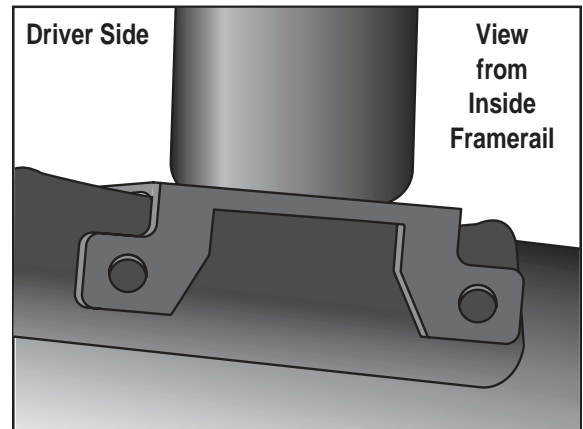

Figure 3

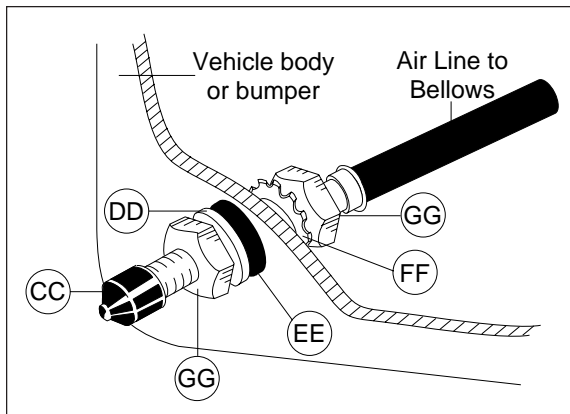

Figure 6

IV. Installing the Air Lines

1. Choose a convenient location for mounting the inflation valves. Popular locations for the inflation valve are: the wheel well flanges, license plate recess in bumper, under the gas cap access door, or through license plate itself.

NOTE: What ever the chosen location is, make sure there is enough clearance around the inflation valves for an air chuck.

2. Drill a $\frac{5}{16}$ " hole to install the inflation valves.
3. Cut the air line assembly (AA) in two equal lengths.

CAUTION: When cutting or trimming the air line, use a hose cutter (Air Lift P/N 10530), a razor blade or a sharp knife. A clean, square cut will ensure against leaks. Do not use wire cutters or scissors to cut the air line. These tools may flatten or crimp the air line, causing it to leak around the O-ring seal inside the elbow fitting.

4. Place a $\frac{5}{16}$ " nut (GG) and a star washer (FF) on the air valve.

Leave enough of the inflation valve in front of the nut to extend through the hole and have room for the rubber washer (EE), flat washer (DD), and $\frac{5}{16}$ " nut (GG) and cap (CC). There should be enough valve exposed after installation - approximately $\frac{1}{2}$ " - to easily apply a pressure gauge or an air chuck (Figure 6).

5. Push the inflation valve through the hole and use the rubber washer (EE), flat washer (DD), and another $\frac{5}{16}$ " nut (GG) to secure it in place. Tighten the nuts to secure the assembly in place (Figure 6).
6. Route the air line along the frame to the air fitting on the air spring. Keep at least 6" of clearance between the air line and heat sources, such as the exhaust pipes, muffler, or catalytic converter. Avoid sharp bends and edges. Use the plastic tie straps (BB) to secure the air line to fixed, non-moving points along the chassis. Be sure that the tie straps are tight, but do not pinch the air line. Leave at least 2" of slack to allow for any movement that might pull on the air line.
7. Cut off air line leaving approximately 12" of extra air line. A clean square cut will ensure against leaks. Insert the air line into the air fitting. This is a push to connect fitting. Simply push the air line into the 90° swivel fitting until it bottoms out ($\frac{9}{16}$ " of air line should be in the fitting).

V. Aligning and Tightening the Assembly

1. With the hose installed, inflate the assembly to 10 ft-lbs.
2. Align assembly by using the slot in the upper air spring mount. The sleeve should be vertical and perpendicular to both of the brackets.
3. Mount the lower bracket by center punching both of the forward holes in the bracket. Drill two $\frac{1}{4}$ " holes in the plate. Attach the lower bracket with two $\frac{5}{16}$ " self-tapping screws.

NOTE: Two sets of $\frac{5}{16}$ " self-tapping screws are supplied. Use the shorter screws for this step.

4. Tighten the nylon nuts on the sleeves to 4 ft-lbs.

VI. Checking for Leaks

1. Inflate the air spring to 30 p.s.i.
2. Spray all connections and the inflation valves with a solution of $\frac{1}{5}$ liquid dish soap and $\frac{4}{5}$ water to check for leaks. You should be able to spot leaks easily by looking for bubbles in the soapy water.
3. After the test, deflate the springs to the minimum pressure required to restore the Normal Ride Height, but not less than 10 p.s.i.
4. **IMPORTANT:** Check the air pressure again after 24 hours. A 2 to 4 p.s.i. loss after initial installation is normal. Retest for leaks if the loss is more than 5 lbs.

VII. Fixing Leaks

1. If there is a problem with the swivel fitting, then:
 - a. Check the air line connection by deflating the spring and removing the line by pulling the collar against the fitting and pulling firmly on the air line. Trim 1" off the end of the air line. Be sure the cut is clean and square. Reinsert the air line into the push-to-connect fitting.
 - b. Check the threaded connection by tightening the swivel fitting another $\frac{1}{2}$ turn. If it still leaks, deflate the air spring, remove the fitting, and re-coat the threads with thread sealant. Reinstall by hand tightening as much as possible, then use a wrench for an additional two turns.
2. If there is a problem with the inflation valve, then:
 - a. Check the valve core by tightening the it with a valve core tool.
 - b. Check the air line connection by removing the air line from the barbed type fitting. **CAUTION: Do not cut it off. As this will usually nick the barb and render the fitting useless.** Cut air line off a few inches in front of the fitting and use a pair of pliers or vise-grips to pull/twist the air line off the fitting.
3. If the preceding steps have not resolved the problem, call Air Lift Technical Service at 1-800-248-0892 for assistance.

VIII. Troubleshooting Guide

Problems maintaining air pressure, without on-board compressor.

1. Leak test the air line connections and threaded connection of the elbow into the air spring. See Section VII to repair.
2. Leak test the inflation valve for leaks at the air line connection or dirt or debris in the valve core. See Section VII to repair.
3. Inspect air lines to be sure it is not pinched. Tie straps may be too tight. Loosen or replace strap. Replace leaking components.
4. Inspect air line for holes and cracks. Replace as needed.
5. A kink or fold in the air line. Reroute as needed.

You have now tested for all of the most probable leak conditions that can be easily fixed. At this point the problem is most likely a failed air spring - either a factory defect or an operating problem. Please call Air Lift at 1-800-248-0892 for assistance or a replacement air spring.

IX. Maintenance and Operations

Minimum Air Pressure	Maximum Air Pressure
10 p.s.i.	100 p.s.i.
<i>Failure to maintain correct minimum pressure (or pressure proportional to load), bottoming out, over-extension, or rubbing against another component will void the warranty.</i>	

By following these steps, vehicle owners will obtain the longest life and best results from their air springs.

1. Check the air pressure weekly.
2. Always maintain Normal Ride Height. Never inflate beyond 100 p.s.i.
3. If you develop an air leak in the system, use a soapy water solution to check all air line connections and the inflation valve core before deflating and removing the air spring.
4. When increasing load, always adjust the air pressure to maintain the Normal Ride Height. Increase or decrease pressure from the system as necessary to attain Normal Ride Height for optimal ride and handling. Remember that loads carried behind the axle (including tongue loads) require more leveling force (pressure) than those carried directly over the axle.
5. **IMPORTANT:** For your safety and to prevent possible damage to your vehicle, *do not exceed maximum Gross Vehicle Weight Rating (GVWR), as indicated by the vehicle manufacturer.* Although your air springs are rated at a maximum inflation pressure of 100 p.s.i. The air pressure actually needed is dependant on your load and GVWR, which may be less than 100 p.s.i. Check your vehicle owners manual and do not exceed the maximum load listed for your vehicle.
6. Always add air to springs in small quantities, checking the pressure frequently. Sleeves require less air volume than a tire and inflate quickly.
7. *Should it become necessary to raise the vehicle by the frame, make sure the system is at minimum pressure (10 p.s.i.) to reduce the tension on the suspension/brake components. Use of on-board leveling systems do not require deflation or disconnection.*

Thank you for purchasing Air Lift Products



Mailing Address:
AIR LIFT COMPANY
P.O. Box 80167
Lansing, MI 48908-0167

Street Address:
AIR LIFT COMPANY
2727 Snow Rd.
Lansing, MI 48917

Local Phone: (517) 322-2144
Fax: (517) 322-0240
<http://www.airliftcompany.com>

For Technical Assistance call 1-800-248-0892

“The Choice of the Professional Installer”

Printed in the USA