

Kit No. 59521 Fits Multi-Steel Leaf Spring Models Only www.airliftcompany.com

Please read these instructions completely before proceeding with installation

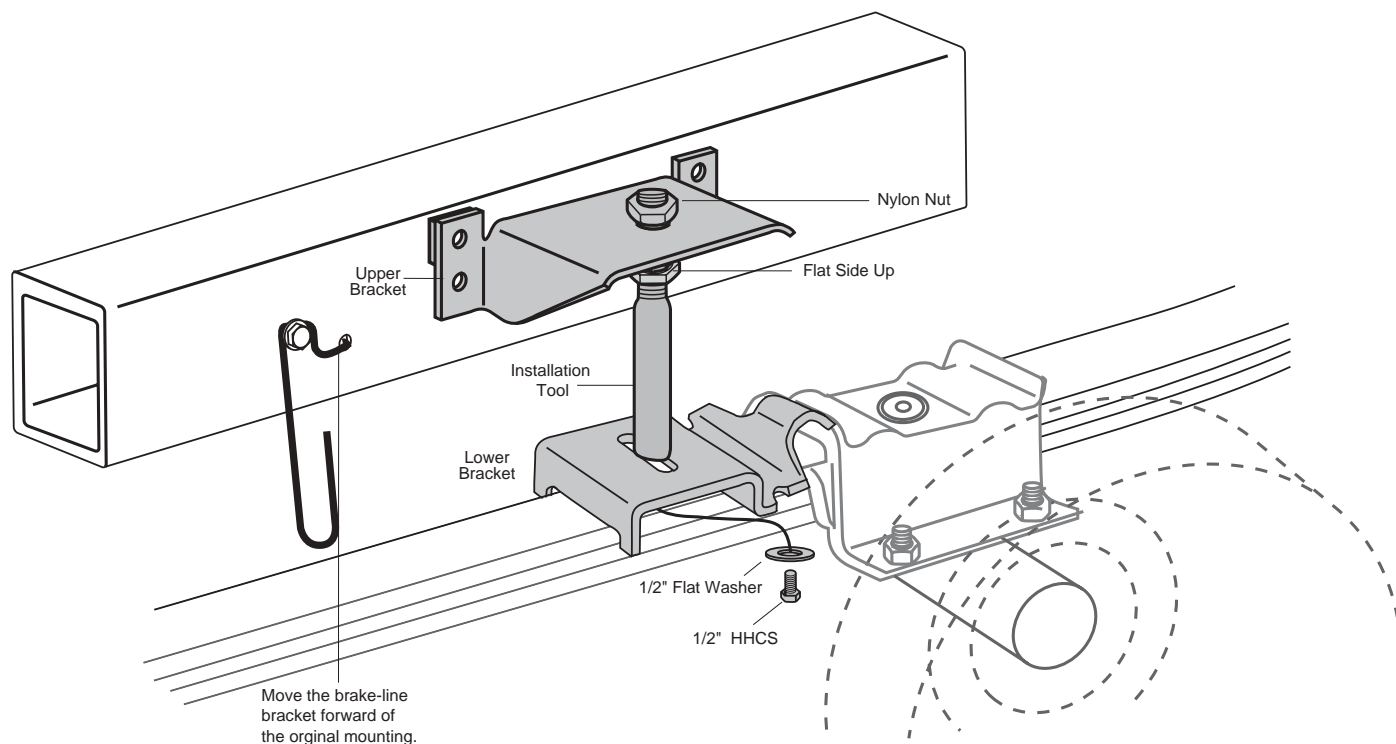

Figure 1

Hardware

Item	P/N	Description	Qty.	Item	P/N	Description	Qty.
A	58287	Sleeve Assembly	2	P	17129	3/8" x 1" Self-Tapping Screw	3
B	07980	Upper Bracket	2	Q	10551	Hose Clip	4
C	03616	Lower Bracket	2	R	17173	#14 x 3/4" Self-Tapping Screw	4
D	10591	Alignment Tool	1	S	10466	Zip Tie	10
E	18454	3/4 - 16 Hex Nut	2	T	09484	Thermal Sleeve	2
F	17124	1/2 - 13 x 7/8" Bolt	2	U	13377	Shim	2
G	18414	1/2" Flat Washer	2	AA	20086 _{SUB}	Air Line Assembly	1
H	01426	3" Lower Clamp Bar	2	BB	21230	Poly Caps	2
I	10975	3/8 - 16 x 3" U-bolt	2	CC	18501	M8 Flat Washer	2
J	18435	3/8 - 16 Nylon lock Nut	10	DD	21234	Rubber Washer	2
K	18444	3/8" Flat Washer	4	EE	18411	5/16" Lock Washer	2
L	17145	3/8 - 16 x 4" Bolt GD5	6	FF	21233	5/16" Hex Nut	4
M	18447	3/8" I.D. x 1 3/8" O.D. Flat Washer	6				
O	21848	1/8" x 1/4" Tube Elbow	2				



Please carefully read the notes below before beginning installation.

This kit contains the Air Lift installation tool: This tool is designed to simplify the installation of the kit for correct mounted height and alignment. The threaded section of the tool will ensure mounting of the air spring within the 5.5" to 7" mounting range. The air spring may be mounted anywhere within that range.

IMPORTANT: If your vehicle is equipped with rear air conditioning, it will be necessary to move the lines up to the top of the frame to install the air spring kit.

IMPORTANT: The life of your air spring will be extended if they are not the suspension limiter in either compression or extension. The air spring compresses to 3" and extends to 8.1". Keeping the minimum required pressure or a pressure proportional to the load will prevent bottoming out. The shock absorber is usually the limiter on extension. If this is not the case, you should consider the use of limiting straps; especially if the vehicle is used off-road. The maximum inflated diameter of your air spring is 4.5". You must check to see that nothing is rubbing against the air spring within this diameter.

IMPORTANT: Failure to maintain correct minimum pressure (or pressure proportional to load), bottoming out, overextension, or rubbing against another component will void the warranty.

DANGER: Compressed air can cause injury and damage to the vehicle and parts if it is not handled properly. For your safety, do not try to inflate the air springs until they have been properly secured to the vehicle.



I. Getting Started

1. Determine the Normal Ride Height. The Normal Ride Height is the distance between the bottom edge of the wheel-well and the center of the hub with the vehicle in the "as delivered" condition. In some cases, Normal Ride Height is not perfectly level.
 - a. Remove unusual loads and examine your vehicle from the side to ensure it is on a level surface.
 - b. If necessary (in cases where your leaf springs are sagging badly), use a jack to raise the rear end so that the vehicle achieves the original "as delivered" ride height.
2. Measure the distance between the center of the hub and the bottom edge of the wheel well. This is the Normal Ride Height. Enter the measurement below:

NORMAL
RIDE HEIGHT: _____ inches



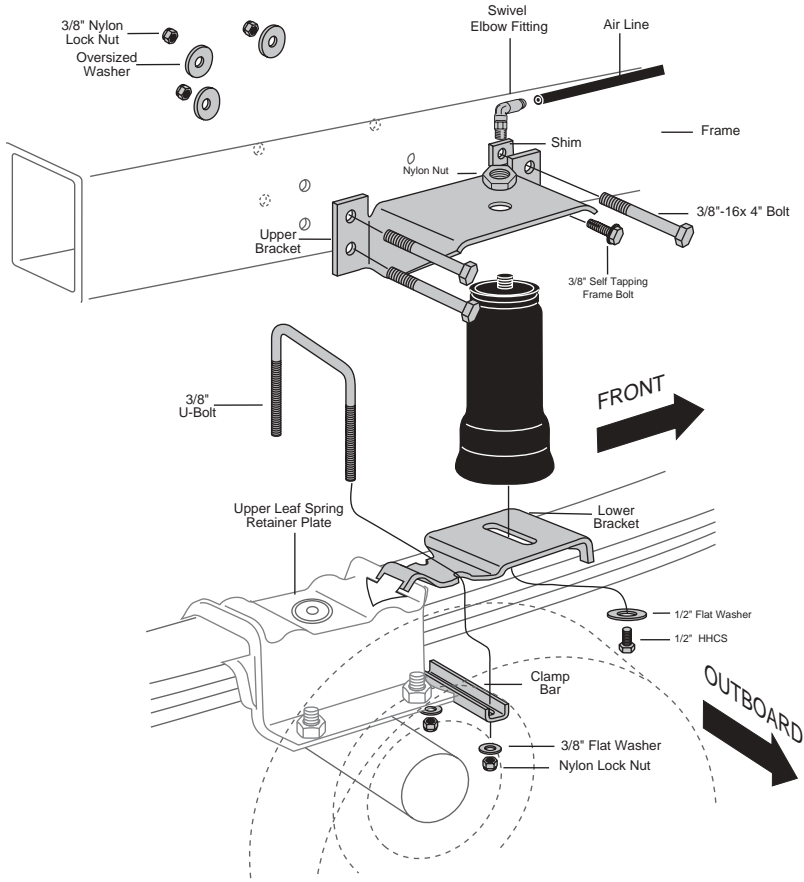

Figure 2

The illustration to the left represents a typical installation. Your vehicle may look slightly different due to make, model, or year.

3. Jack up the rear of the vehicle or raise on a hoist. Raise the axle or lower the frame until the leaf spring is at normal ride height (unloaded condition).
4. Measure the distance between the tire and the outside of the frame rail. There must be a minimum of 5.5" to provide clearance for the air spring when fully inflated.

II. Assembling the Air Spring Unit

1. Place the upper bracket (B) onto the threaded end of the alignment tool (D). Thread a nylon nut (E) onto the tool to hold the bracket in place. Leave loose at this time (Figure 1).
2. Using a 1/2" bolt (F) and flat washer (G), attach the lower bracket (C) to the bottom of the installation tool.
3. Set the preassembled bracket unit on the leaf spring forward of the axle.

III. Installing the Air Spring Unit

1. Place the hook end of the lower bracket over the edge of the upper spring retaining plate. Secure the lower bracket to the leaf spring with the provided clamp bar (H), U-bolt (I), flat washers (K), and nylon lock nuts (J). Torque to 16 lb.-ft.

NOTE: On some conversions, it may be necessary to trim the seat bolts that protrude down from the floorboard in the area where the assembly is mounted.

NOTE: Some models have a brake-line bracket that mounts on the driver-side frame rail. In order to mount the upper bracket to the frame, the brake-line bracket will have to be relocated forward. Proceed to step IV, Relocating the Brake-Line Bracket.

If this is not necessary for your model vehicle, proceed to step V, Installing the Air Spring Unit (continued).

IV. Relocating the Brake-Line Bracket

Refer to figure 1 when relocating the brake-line bracket.

1. Remove the existing bolt from the frame and discard.
2. Set the air spring assembly into position forward of the axle and set the brake-line bracket onto the frame just forward of the upper bracket.
3. Drill a 5/16" hole to insert a self-tapping screw (P).
4. Bend the tab or drill another hole for indexing the tab on the brake-line bracket. Set the brake-line bracket in place and install the self-tapping screw.

NOTE: Be careful not to over-tighten the screw to avoid stripping the thread.

V. Installing the Air Spring Unit (continued)

Using the slot in the lower bracket, push the upper bracket against the frame rail. Use the hex nuts on the threaded portion of the installation tool to adjust the upper bracket (up and down) so that the flanges of the upper bracket are flat against the frame rail and all four mounting holes are on the flat middle section of the frame rail. The mounting holes must be at least 3/4" from the rounded edges of the frame rail.

IMPORTANT NOTE: There must be at least 1.5" above the upper bracket for air fitting clearance. The brackets can be mounted anywhere within the threaded range of the installation tool (Figure 1).

Using the upper bracket as a template, follow the specific directions for the PASSENGER and DRIVER sides.

PASSENGER-SIDE:

- a. Centerpunch and drill a 3/8" hole through the forward, upper mounting hole. Place a shim (U) between the upper bracket and the frame and attach using a 3/8" bolt. Secure using a flat washer (M) and a nylon lock nut (J) (Figure 2). Leave loose at this time.

NOTE: On the exhaust side of the vehicle, it may be necessary to move or trim the stock heat shield to gain access to the mounting bolts.

- b. Centerpunch and drill through the rear, upper mounting holes. Do not insert the bolt.
- c. Remove the installation tool by removing the upper hex nut, loosening and removing the tool from the bottom bolt (leave in place), and slightly rotating the upper bracket to leave enough room to remove the tool.
- d. Rotate the upper bracket back to the original location and install a bolt (L), flat washer(M), and nylon lock nut (J) through the second hole that was drilled.

- e. Tighten both of the installed fasteners to 20 lb.-ft.
- f. Centerpunch and drill a third 3/8" hole through the rear, lower mounting hole and insert a 3/8" bolt (L), flat washers (M), and a nylon lock nut (J). Tighten to 20 lb.-ft.
- g. A self-tapping screw (P) is required in the forward, lower mounting hole (Figure 3). Drill a 5/16" hole and insert and tighten the self-tapping screw.

NOTE: Be careful not to over-tighten the screw to avoid stripping the threads.

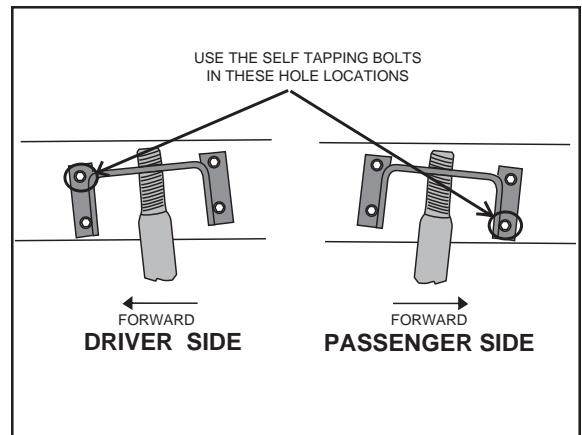

Figure 3

DRIVER-SIDE:

- a. Centerpunch and drill a 3/8" hole through the forward, lower mounting hole. Insert the 3/8" bolt (L), flat washers (M), and nylon lock nut (J). Leave loose at this time.
 - b. Centerpunch and drill a 3/8" hole through the rear, lower mounting hole. Do not insert the bolt.
 - c. You can now remove the installation tool by removing the upper hex nut, loosening and removing the tool from the bottom bolt (leave in place), and slightly rotating the upper bracket to give you enough room to completely remove the tool.
 - d. Rotate the upper bracket back to the original location and install a bolt (L), flat washer (M), and nylon lock nut (J) through the second hole that was drilled.
 - e. Centerpunch and drill a third 3/8" hole through the rear, upper mounting hole and insert a 3/8" bolt (L), flat washers (M), and nylon lock nut (J).
 - f. A self-tapping screw (P) is required in the forward, upper mounting hole (Figure 3). Drill a 5/16" hole and place a shim (U) between the upper bracket and the frame. Insert and tighten the self-tapping screw.
- NOTE: Be careful not to over-tighten the screw to avoid stripping the threads.*
- g. Tighten all the other hardware to 20 lb.-ft.

Install the pre-coated air fitting (O) into the thread post of the air spring (A). Tighten finger-tight plus 1 1/2 turns.

NOTE: Use a 7/16" open-end wrench being careful to tighten on the metal hex nut only. DO NOT OVERTIGHTEN

Carefully thread the bottom of the air spring onto the bolt in the lower bracket. Leave loose at this time.

Insert the top of the air spring through the hole in the upper bracket and attach with a hex nut (E) (Figure 1). Leave loose at this time.

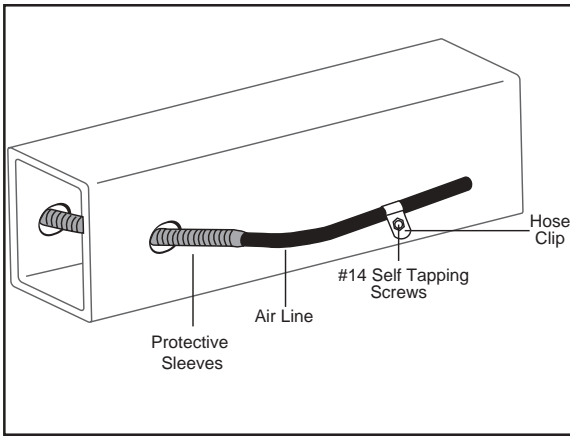

Figure 4

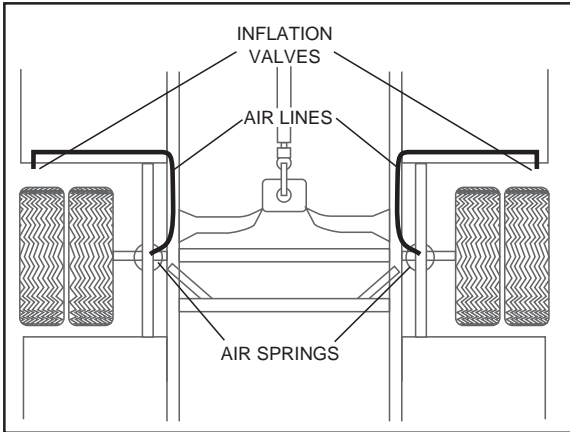

Figure 5

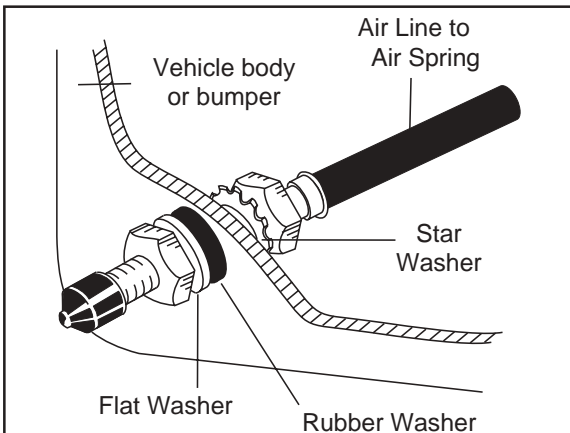

Figure 6

VI. Installing the Air Lines

1. Choose a convenient location for mounting the inflation valves (Figure 5). Popular locations for the inflation valve are:
 - a. The wheel well flanges.
 - b. License plate recess in bumper.
 - c. Under the gas cap access door.
 - d. Through license plate itself.

NOTE: Whatever the chosen location is, make sure there is enough clearance around the inflation valves for an air chuck.

2. Drill a 5/16" hole to install the inflation valves (Figure 6).
3. Cut the air line assembly (AA) in two equal lengths.

CAUTION: When cutting or trimming the air line, use a hose cutter (Air Lift P/N 10530), a razor blade or a sharp knife. A clean, square cut will ensure against leaks. Do not use wire cutters or scissors to cut the air line. These tools may flatten or crimp the air line, causing it to leak around the O-ring seal inside the elbow fitting.
4. Place a 5/16" nut (GG) and a star washer (FF) on the air valve. Leave enough of the inflation valve in front of the nut to extend through the hole and have room for the rubber washer (EE), flat washer (DD), and 5/16" nut (GG) and cap (CC). There should be enough valve exposed after installation - approximately 1/2" - to easily apply a pressure gauge or an air chuck.
5. Push the inflation valve through the hole and use the rubber washer (EE), flat washer (DD), and another 5/16" nut (GG) to secure it in place. Tighten the nuts to secure the assembly in place (Figure 6).
6. Route the air line along the frame to the air fitting on the air spring (Figure 5). Keep at least 6" of clearance between the air line and heat sources, such as the exhaust pipes, muffler, or catalytic converter. Avoid sharp bends and edges. Use the plastic zip ties (BB) to secure the air line to fixed, non-moving points along the chassis. Be sure that the zip ties are tight, but do not pinch the air line. Leave at least 2" of slack to allow for any movement that might pull on the air line.

7. Cut off air line leaving approximately 12" of extra air line. A clean square cut will ensure against leaks.
8. To properly instal the air line, measure 9/16" from the cut end and mark with tape. Lubricate (i.e. soap solution, silicone spray, saliva) the end of the air line and insert it into the fitting. This is a push to connect fitting. A click can be heard/felt when the air line is seated, also, the front edge of the tape band should be flush with the fitting. The air line is now installed.

VII. Finishing the Installation

1. With the bottom still loose, inflate the air spring to approximately 10 PSI By using the slotted adjustment in the lower bracket, align the air spring so that there is a symmetrical cushion of air around the lower base. This can be accomplished by pressing all around the air spring and tapping it inboard and outboard for proper alignment (Figure 7).
2. Tighten the lower end by holding the bolt with a wrench and turning the air spring by hand - use no tools - hand-tight is sufficient. Some air may need to be let out of the air spring.
3. Tighten the upper hex nut to 4 lb.-ft. Do not over-tighten.

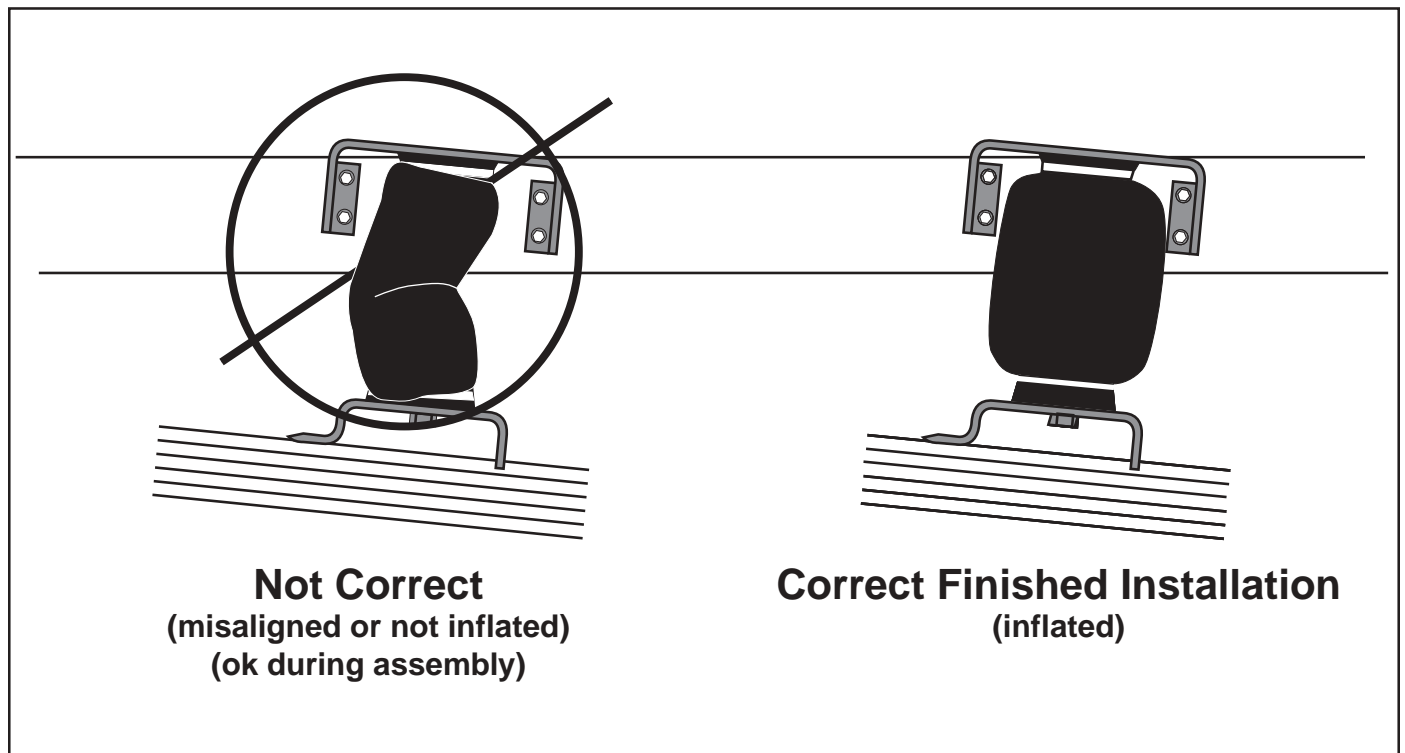

Figure 7

VIII. Checking for Leaks

1. Inflate the air spring to 30 PSI.
2. Spray all connections and the inflation valves with a solution of 1/5 liquid dish soap and 4/5 water to check for leaks. You should be able to spot leaks easily by looking for bubbles in the soapy water.
3. After the test, deflate the air springs to the minimum pressure required to restore the Normal Ride Height, but not less than 10 PSI.
4. **IMPORTANT:** Check the air pressure again after 24 hours. A 2 to 4 PSI loss after initial installation is normal. Retest for leaks if the loss is more than 5 lbs.

IX. Fixing Leaks

1. If there is a problem with the swivel fitting:
 - a. Check the air line connection by deflating the spring and removing the line by pulling the collar against the fitting and pulling firmly on the air line. Trim 1" off the end of the air line. Be sure the cut is clean and square. Reinsert the air line into the push-to-connect fitting.
 - b. Check the threaded connection by tightening the swivel fitting another 1/2 turn. If it still leaks, deflate the air spring, remove the fitting, and re-coat the threads with thread sealant. Reinstall by hand tightening as much as possible, then use a wrench for an additional two turns.
2. If there is a problem with the inflation valve:
 - a. Check the valve core by tightening it with a valve core tool.
 - b. Check the air line connection by removing the air line from the barbed type fitting. **CAUTION: Do not cut it off. As this will usually nick the barb and render the fitting useless.** Cut air line off a few inches in front of the fitting and use a pair of pliers or locking pliers to pull/twist the air line off the fitting.
3. If the preceding steps have not resolved the problem, call Air Lift Technical Service at 1-800-248-0892 for assistance.

X. Troubleshooting Guide

Problems maintaining air pressure, without on-board compressor.

1. Leak test the air line connections and threaded connection of the elbow into the air spring. See Section IX to repair.
2. Leak test the inflation valve for leaks at the air line connection or dirt or debris in the valve core. See Section IX for repair.
3. Inspect air lines to be sure it is not pinched. Zip ties may be too tight. Loosen or replace zip tie. Replace leaking components.
4. Inspect air line for holes and cracks. Replace as needed.
5. A kink or fold in the air line. Reroute as needed.

You have now tested for all of the most probable leak conditions that can be easily fixed. At this point the problem is most likely a failed air spring - either a factory defect or an operating problem. Please call Air Lift at 1-800-248-0892 for assistance or a replacement air spring.

XI. Checklist

You can protect your warranty on this product and prevent unnecessary wear by ensuring the following checks have been made:

Section I – Installation (To be completed by the installer):

- 1. Clearance Test - Inflate the air springs to 60 PSI and ensure there is at least 1/2" clearance around each sleeve from anything that might rub against them. Be sure to check the tire, brake drum, frame, shock absorbers and brake cables.
- 2. Leak Test Before Road Test – Inflate the air springs to 60 PSI, check all connections for leaks with a soapy water solution. See pages 8 and 9 of the manual for tips on how to spot leaks. All leaks must be eliminated before the vehicle is road tested.
- 3. Heat Test – Be sure there is sufficient clearance from heat sources - at least 6" for air springs and air lines. If a heat shield was included in the kit - install it. If there is no heat shield, but one is required, call 1-800-248-0892.
- 4. Fastener Test – Recheck all bolts for proper torque.

Torque Guide:

Frame Bolts	20 lb.-ft.
U-bolt Lock Nuts	16 lb.-ft.
Lower Mounting Bolt on Air Sleeve	10 lb.-ft.
- 5. Road Test – The vehicle should be road tested after the preceding tests. Inflate the air springs to 25 PSI (50 PSI if vehicle is loaded). Drive the vehicle 10 miles and recheck for clearance, loose fasteners and/or air leaks.
- 6. Operating Instructions – If professionally installed, the installer should review the operating instructions on page 10 with the owner. Be sure to provide the owner with all of the paperwork that came with the kit.

Section II - Post Installation Checklist (To be completed by the owner):

- 1. Overnight Leakdown Test – Recheck air pressure after vehicle has been used for 24 hours. If pressure has dropped more than 5 PSI then, you have a leak that must be fixed. Either fix the leak yourself or return to the installer for service.
- 2. Air Pressure Requirements – I understand that the air pressure requirements of my air spring system are as follows:

Minimum _____ Maximum _____

I also understand that I must inflate the air springs until the Ride Height measurement that was recorded on page 3 has been restored. Regardless of load, the air pressure should always be adjusted so that the Ride Height is maintained at all times.

- 3. Thirty Day or 500 Mile Test. I understand that I must recheck the air spring system after 30 days or 500 miles, whichever comes first. If any part shows signs of rubbing or abrasion, the source should be identified and moved, if possible. If it is not possible to relocate the cause of the abrasion, the air spring may need to be remounted. If professionally installed, the installer should be consulted. Check all fasteners for tightness.

XII. Maintenance and Operations

Minimum Air Pressure	Maximum Air Pressure
5 PSI	100 PSI
<i>Failure to maintain correct minimum pressure (or pressure proportional to load), bottoming out, over-extension, or rubbing against another component will void the warranty.</i>	

By following these steps, vehicle owners will obtain the longest life and best results from their air springs.

1. Check the air pressure weekly.
2. Always maintain Normal Ride Height. Never inflate beyond 100 PSI.
3. If you develop an air leak in the system, use a soapy water solution to check all air line connections and the inflation valve core before deflating and removing the air spring.
4. When increasing load, always adjust the air pressure to maintain the Normal Ride Height. Increase or decrease pressure from the system as necessary to attain Normal Ride Height for optimal ride and handling. Remember that loads carried behind the axle (including tongue loads) require more leveling force (pressure) than those carried directly over the axle.
5. **IMPORTANT:** For your safety and to prevent possible damage to your vehicle, *do not exceed maximum Gross Vehicle Weight Rating (GVWR), as indicated by the vehicle manufacturer.* Although your air springs are rated at a maximum inflation pressure of 100 PSI, the air pressure actually needed is dependent on your load and GVWR, which may be less than 100 PSI. Check your vehicle owners manual and do not exceed the maximum load listed for your vehicle.
6. Always add air to springs in small quantities, checking the pressure frequently. Sleeves require less air volume than a tire and inflate quickly.
7. *Should it become necessary to raise the vehicle by the frame, make sure the system is at minimum pressure (5 PSI) to reduce the tension on the suspension/brake components. Use of on-board leveling systems do not require deflation or disconnection.*

Warranty and Returns Policy

Air Lift Company provides a limited lifetime warranty to the original purchaser of its load support products, that the products will be free from defects in workmanship and materials when used on cars and trucks as specified by Air Lift Company and under normal operating conditions, subject to the requirements and exclusions set forth in the full Limited Warranty and Return Policy that is available at www.airliftcompany.com/warranty.

For additional warranty information contact Air Lift Company customer service.



Thank you for purchasing Air Lift Products

Mailing Address:
AIR LIFT COMPANY
P.O. Box 80167
Lansing, MI 48908-0167

Street Address:
AIR LIFT COMPANY
2727 Snow Rd.
Lansing, MI 48917

Local Phone: (517) 322-2144

Fax: (517) 322-0240

<http://www.airliftcompany.com>

For Technical Assistance call 1-800-248-0892